



FRAMEWORK FOR DIRECT POTABLE REUSE



WATERREUSE



American Water Works
Association



**Water Environment
Federation**
the water quality people®

NWRI | National
Water
Research
Institute



Framework for Direct Potable Reuse

About WateReuse

WateReuse is internationally-recognized as a thought-leader on alternative water supply development. Comprised of two organizations that provide a comprehensive and complementary approach to building support for water reuse as an essential component of any water supply, WateReuse has a unique singular focus on helping communities transform a previously wasted resource into a safe, reliable supply of water to meet growing demand. The WateReuse Association is a nonprofit coalition of utilities, government agencies and industry that advocates for laws, policies and funding to promote water reuse. The WateReuse Research Foundation is a nonprofit charitable organization that conducts research to improve the treatment, distribution and acceptance of recycled water.

About the American Water Works Association

Established in 1881, the American Water Works Association is the largest nonprofit, scientific and educational association dedicated to managing and treating water, the world's most important resource. With approximately 50,000 members, AWWA provides solutions to improve public health, protect the environment, strengthen the economy and enhance our quality of life.

About the Water Environment Federation

The Water Environment Federation (WEF) is a not-for-profit technical and educational organization of 36,000 individual members and 75 affiliated Member Associations representing water quality professionals around the world. Since 1928, WEF and its members have protected public health and the environment. As a global water sector leader, our mission is to connect water professionals; enrich the expertise of water professionals; increase the awareness of the impact and value of water; and provide a platform for water sector innovation. To learn more, visit www.wef.org.

About the National Water Research Institute

Since 1991, the National Water Research Institute (NWRI)—a science-oriented 501c3 nonprofit—has sponsored projects and programs to improve water quality, protect public health and the environment, and create safe, new sources of water. NWRI specializes in working with researchers across the country with the best available facilities, such as laboratories at universities and water agencies, and is guided by a Board of Directors made up of representatives of water and wastewater agencies in California. NWRI hosts the annual Athalie Richardson Irvine Clarke Prize, one of only a dozen prizes that awards scholarly and practical achievements in water research. To learn more about NWRI, please visit www.nwri-usa.org.

Framework for Direct Potable Reuse

Independent Advisory Panel

George Tchobanoglous, PhD, PE, NAE, BCEE (Panel Chair)
University of California, Davis

Joseph Cotruvo, PhD, BCES
Joseph Cotruvo & Associates, LLC

James Crook, PhD, PE, BCEE
Environmental Engineering Consultant

Ellen McDonald, PhD, PE
Alan Plummer Associates, Inc.

Adam Olivieri, DrPH, PE
EOA, Inc.

Andrew Salveson, PE
Carollo Engineers, Inc.

R. Shane Trussell, PhD, PE, BCEE
Trussell Technologies, Inc.

Editors

Jeffrey J. Mosher and Gina Melin Vartanian, National Water Research Institute

Cosponsors

American Water Works Association
Water Environment Federation
National Water Research Institute



Disclaimer

This report was sponsored by the WateReuse Research Foundation and cosponsored by the American Water Works Association, Water Environment Federation, and National Water Research Institute. The Foundation, its Board Members, and the project cosponsors assume no responsibility for the content of this publication or for the opinions or statements of facts expressed in the report. The mention of trade names of commercial products does not represent or imply the approval or endorsement of the WateReuse Research Foundation, its Board Members, or the cosponsors. This report is published solely for informational purposes.

For more information, contact:

WateReuse Research Foundation
1199 North Fairfax Street, Suite 410
Alexandria, VA 22314
703-548-0880
703-548-5085 (fax)
www.WateReuse.org

© Copyright 2015 by the WateReuse Research Foundation. All rights reserved. Permission to reproduce must be obtained from the WateReuse Research Foundation.

WateReuse Project Number: 14-20

ISBN: 978-1-941242-30-8

Contents

List of Tables.....	ix
List of Figures	xi
List of Abbreviations and Acronyms	xii
List of Abbreviations for Units of Measure.....	xiv
List of Useful Terminology	xv
Foreword	xix
Preface.....	xx
Acknowledgments	xxii
Chapter 1. Introduction	1
1.1 Overview of Potable Reuse.....	1
1.2 Need for Direct Potable Reuse Guidance	2
1.3 Purpose of the Framework Document	2
1.4 Organization of the Framework Document	3
1.5 References	4
Chapter 2. What Is Direct Potable Reuse?.....	5
2.1 Direct Potable Reuse.....	5
2.2 Indirect Potable Reuse	7
2.3 New Raw Potable Water Source (Advanced Treated Water)	8
2.4 Examples of Direct Potable Reuse Projects.....	8
2.5 Cost of Direct Potable Reuse	9
2.6 Energy Requirements for Direct Potable Reuse	13
2.7 Comparative Issues with Other Water Sources and Measures to Direct Potable Reuse.....	15
2.8 References	17
Chapter 3. Key Components of a Successful/Sustainable Direct Potable Reuse Program	19
3.1 Regulatory Component	19
3.2 Technical Component	21
3.3 Public Outreach Component.....	24
3.4 Technical, Operational, and Management Multiple Barriers.....	24
3.5 Direct Benefits/Impacts of Implementing Direct Potable Reuse	26
3.6 References	27
Chapter 4. Public Health and Regulatory Aspects for Direct Potable Reuse	29
4.1 Public Health Protection	29
4.2 Overview of Health Effects Assessments	29
4.3 Clean Water Act.....	32

4.4 Applicable Regulations	33
4.5 Criteria for Direct Potable Reuse	37
4.6 Advanced Treated Water as a Raw Potable Water Source	41
4.7 References	41
Chapter 5. Source Control Program	45
5.1 Importance of a Source Control Program for Direct Potable Reuse	45
5.2 Overview of the National Pretreatment Program	45
5.3 Federal Pretreatment Standards	46
5.4 Development of a Source Control Program for Direct Potable Reuse	47
5.5 Principal Elements of a Source Control Program for Direct Potable Reuse	49
5.6 Source Control Program Expectations	49
5.7 Example Source Control Programs Related to Potable Reuse	52
5.8 References	53
Chapter 6. Wastewater Treatment	55
6.1 Overview of Wastewater Treatment	55
6.2 Differences in Wastewater Treatment Train Effluent Quality	58
6.3 Issues Related to the Use of Wastewater Treatment Plant Effluent in Potable Reuse Applications	60
6.4 The Value of Higher Quality Secondary Effluent and Tertiary Treatment for Potable Reuse Applications	62
6.5 Impacts of Climate Change and Water Conservation	64
6.6 References	66
Chapter 7. Advanced Water Treatment	69
7.1 Overview of Advanced Water Treatment	69
7.2 Treatment Technologies and Trains Used for Advanced Water Treatment	71
7.3 Process Control for Water Quality Assurance	74
7.4 The Role of the Engineered Storage Buffer	77
7.5 Design Considerations for Advanced Water Treatment	78
7.6 Contingency Plans for Advanced Water Treatment Facility Flow Rate Interruptions	85
7.7 Alternative Technologies	85
7.8 References	86

Chapter 8. Management of Advanced Treated Water.....	91
8.1 Blending of Advanced Treated Water with Other Source Waters before Drinking	
Water Treatment	91
8.2 Microbial Log Reduction Credits for Surface Water Treatment	93
8.3 Blending Finished Water with Other Drinking Water	94
8.4 Process Control for Deviations from Performance Specifications	94
8.5 Process Control for Flow Interruptions and Diurnal Flow Variations	95
8.6 References	96
Chapter 9. Process Monitoring	97
9.1 Overview of Process Monitoring	97
9.2 Monitoring for Pathogens	97
9.3 Monitoring for Chemical Constituents	98
9.4 Process Monitoring during Startup and Documentation of Baseline Performance	98
9.5 Long-Term Performance Monitoring.....	100
9.6 Special Studies	102
9.7 References	104
Chapter 10. Residuals Management	105
10.1 What Residuals Result from an Advanced Water Treatment Facility?	105
10.2 Management of Non-RO Concentrate Residuals.....	105
10.3 Management of RO Concentrate	106
10.4 Regulatory Concerns with the Management of Non-RO Residuals	109
10.5 Regulatory Concerns with the Management of RO Concentrate	109
10.6 Cost of RO Concentrate Management.....	110
10.7 References	110
Chapter 11. Facility Operation	113
11.1 Overview of Facility Operations and Maintenance	113
11.2 Facility Startup and Commissioning	113
11.3 Operation during the First Year.....	114
11.4 Advanced Water Treatment Facility Operators	115
11.5 Advanced Water Treatment Facility Maintenance	116
11.6 Operations Plan.....	116
11.7 References	120
Chapter 12. Public Outreach.....	121
12.1 Establishing the Need for Potable Reuse.....	121
12.2 Overview of Public Outreach for Direct Potable Reuse	121
12.3 Challenges Associated with Outreach for Direct Potable Reuse	122

12.4	Having a Communication Plan	123
12.5	Examples of Outreach Programs for Potable Reuse Projects	128
12.6	References	128

Chapter 13. Future Developments131

13.1	Future Regulatory Needs	131
13.2	Future Technology Needs.....	133
13.3	Future Public Outreach Needs	135
13.4	Reference	135

Appendices

A	Summary of Epidemiology Studies and Bioanalytical Screening Studies.....	137
B	Summary of Example Representative Quantitative Relative Risk Assessments	147
C	Recommended Constituents of Emerging Concern to Be Considered in Direct Potable Reuse Projects.....	151
D	Federal Pretreatment Program Prohibitions.....	155
E	Federal Pretreatment Program—Categorical Pretreatment Standards.....	157
F	Example Source Control Programs.....	159
G	National Primary and Secondary Drinking Water Standards for Chemicals.....	163
H	Biographies of the Independent Advisory Panel Members and Editors	167

Tables

1.1	Guidance Needed for the Three Key Components of a DPR Program.....	3
2.1	Examples of DPR Projects.....	9
2.2	Comparative Unit Costs of Advanced Treated Water, Brackish and Seawater Desalination, and Conservation Measures.....	10
2.3	Summary of Treatment Technologies Employed for the Production of ATW at OCWD.....	11
2.4	Comparative Energy Requirements for Wastewater and Water Treatment, Advanced Water Treatment, and Alternative Sources of Surface Water.....	14
2.5	Comparative Issues with Alternative Sources of Water and Other Water Management Measures to DPR.....	15
3.1	Some Important Issues for Each of the Elements that Compose the Technical Components of a DPR Program.....	22
3.2	Key Activities for Developing a Public Outreach Program for DPR.....	24
4.1	Fundamental Elements of Source Water Protection Programs.....	35
4.2	Microbial Reduction Criteria for AWTF Treatment Trains.....	39
5.1	Key Elements of the National Pretreatment Program.....	47
5.2	Principal Elements of an Enhanced Source Control Program for Direct Potable Reuse.....	50
6.1	Levels of Wastewater Treatment.....	56
6.2	Typical Range of Effluent Quality after Various Levels of Treatment.....	59
6.3	Measures that Can Be Taken to Improve the Performance and Enhance the Reliability of Existing and Proposed WWTPs.....	61
6.4	Benefits in Improved Water Quality and Pathogen Reduction Derived from Filtration and Disinfection after Secondary Treatment.....	65
7.1	Summary of Technologies for Advanced Water Treatment.....	71
7.2	Typical Range of Effluent Quality after Various Levels of Advanced Water Treatment.....	75
7.3	Examples of Pathogen Treatment Critical Control Points for a Typical AWTF Treatment Train.....	76
7.4	Pathogen Log Reduction Credits Achieved by the Two Different Treatment Trains Shown in Figure 7.2.....	81
7.5	Examples of Trace Constituent Removal by Different Advanced Treatment Trains.....	83
7.6	Reliable Treatment Based on Redundancy, Robustness, and Resiliency.....	85
8.1	Potential Water Quality Impacts from Blending Two Different Types of ATW (UF/RO/UV-AOP and O_3 /BAF/UF) with Other Untreated Surface Water Upstream of a DWTF.....	92
8.2	Suggested Tests to Guide the Blending Strategy.....	93

9.1 Pathogen Log Reduction Credits Based on the Example Monitoring Scheme Shown in Figure 9.1	99
9.2 Example Startup Testing for the AWTF Flow Diagram Shown in Figure 9.1	100
9.3 Example Long-Term Online and Calibration Sampling for the Flow Diagram Shown in Figure 9.1	103
9.4 Long-Term Periodic Sampling (All Grab Samples)	103
10.1 Summary of RO Concentrate Processing Options	107
10.2 Summary of RO Concentrate Disposal Options.....	108
10.3 Estimated Unit Cost, Including Capitalized and Operation and Maintenance Costs, for Selected RO Concentrate Disposal Options	110
11.1 Topic Areas Addressed in the Operations Plan Manual Developed for the AWTF Shown in Figure 11.1	118
11.2 Example of Items Addressed within Each Topic Area Identified in Table 11.1	119
11.3 Example of Items Addressed in the Annual Report with Respect to the Performance of the OCWD AWTF Shown in Figure 11.1.....	120
12.1 Examples of Communication and Outreach Challenges	123
12.2 Key Factors that Should Be Considered When Developing a Communication Plan	124
12.3 Examples of Potable Reuse Outreach Strategies	125
12.4 Examples of Communication Plan Tools and Materials	127
12.5 Examples of Potable Reuse Projects in the U.S. with Outreach Programs.....	128
A.1 Summary of Epidemiology Studies.....	137
A.2 Summary of Bioanalytical Screening Studies	141
C.1 Nonregulated Chemicals of Interest from the Standpoint of Public Health (If Present in Wastewater).....	151
C.2 Chemicals that Should Be Useful for Evaluating the Effectiveness of Organic Chemical Removal by Treatment Trains.....	152
E.1 U.S. EPA Pretreatment Categories and Standards	157
G.1 Inorganics with Primary MCLs.....	163
G.2 Constituents/Parameters with Secondary MCLs	164
G.3 Radioactivity	164
G.4 Regulated Organics	165
G.5 Disinfection Byproducts.....	166
G.6 Disinfectants.....	166

Figures

2.1	Flow diagrams for DPR: (a) with AWT introduced upstream of a DWTF; and (b) finished water introduced into the drinking water supply distribution system downstream of a DWTF.....	6
2.2	Flow diagrams for IPR: (a) with a groundwater aquifer as an environmental buffer; and (b) with a surface water reservoir as an environmental buffer.....	8
2.3	Flow diagram for the AWTF at OCWD.....	11
3.1	Interrelationship of the key components of a DPR program.....	19
3.2	Key elements of the multiple-barrier strategy for ensuring water quality in a potable reuse program.	25
5.1	Key elements of the technical component of a potable reuse program.....	48
6.1	Key elements of the technical component of a potable reuse program.....	55
6.2	Generalized process flow diagrams for the typical treatment processes used for conventional wastewater treatment: (a) aerated lagoon for TSS and BOD removal; (b) trickling filter for TSS and BOD removal; (c) activated sludge for TSS and BOD removal and nitrification; (d) suspended growth biological treatment for TSS, BOD, and nitrogen removal; and (e) suspended growth biological treatment for TSS, BOD, nitrogen, and phosphorus removal.....	57
6.3	Generalized process flow diagrams for the typical treatment processes used for wastewater treatment with effluent filtration and disinfection: (a) activated sludge for TSS and BOD removal and nitrification; (b) suspended growth biological treatment for TSS, BOD, and nitrogen removal; and (c) membrane bioreactor with nitrification, nitrogen removal, or both, and effluent filtration.....	58
6.4	Observed reduced membrane fouling and operating pressures for the Groundwater Replenishment System operated by the Orange County Water District after changes were made in March 2010 to allow a nitrification mode at the Orange County Sanitation District.....	63
7.1	Key elements of the technical component of a potable reuse program.....	70
7.2	Three typical advanced water treatment trains for the production of ATW: (a) treatment train employing microfiltration, reverse osmosis, advanced oxidation, and engineered storage buffer with free chlorine; (b) treatment train employing ozone with biologically active filtration, microfiltration, reverse osmosis, and advanced oxidation; and (c) treatment train employing ozone with biologically active filtration, ultrafiltration, advanced oxidation, and engineered storage buffer with free chlorine.....	73
7.3	Different process failure response times depending on the sampling interval and turnaround time, system turnaround time, and system correction time.....	77
9.1	Typical AWTF process flow diagram with critical control points identified for the individual treatment processes for both process control and establishing log reduction credits.....	99
11.1	The flow diagram for the AWTF at the Orange County Water District.....	117

Abbreviations and Acronyms

AF	acre-foot (the volume of water that would cover 1 acre of land to a depth of 1 foot)
AOP	advanced oxidation process
ATW	advanced treated water
AWTF	advanced water treatment facility
BAF	biologically active filtration
BOD	biochemical oxygen demand
CCP	critical control point
CDPH	California Department of Public Health (now DDW)
CECs	constituents of emerging concern (also known as “contaminants of emerging concern”—“constituents” is used in this document)
CFR	Code of Federal Regulations
COCs	constituents of concern (also known as “contaminants of concern”—“constituents” is used in this document)
C-NPR	centralized nonpotable reuse
CT	chlorine residual, C, multiplied by the contact time, T
CWA	Clean Water Act
DBP	disinfection byproduct
DDW	Division of Drinking Water (California State Water Resources Control Board)
DEQ	Oregon Department of Environmental Quality
D-NPR	decentralized nonpotable reuse
DPR	direct potable reuse
DWTF	drinking water treatment facility
EC	electrical conductivity
ED	electrodialysis
ESB	engineered storage buffer
ESWTR	Enhanced Surface Water Treatment Rule
FRT	failure and response time
GWRS	Groundwater Replenishment System
GWUDI	groundwater under the direct influence of surface water
HACCP	hazard analysis and critical control points
HI	hazard index
IAP	Independent Advisory Panel
IPR	indirect potable reuse
IU	industrial user
LT2ESWTR	Long-Term 2 Enhanced Surface Water Treatment Rule
MBR	membrane bioreactor
MCL	maximum contaminant level
MF	microfiltration
NDMA	N-nitrosodimethylamine
NF	nanofiltration
NPDES	National Pollution Discharge Elimination System
NPR	nonpotable reuse
NRC	National Research Council
NWRI	National Water Research Institute
O&M	operation and maintenance
OCSD	Orange County Sanitation District

OCWD	Orange County Water District
PAC	Project Advisory Committee
POTW	publicly owned treatment work
QRRA	quantitative relative risk assessment
RAC	Research Advisory Committee
RO	reverse osmosis
SDWA	Safe Drinking Water Act
SWP	State Water Project
SWPP	Source Water Protection Program
SWRCB	California State Water Resources Control Board
SWTR	Surface Water Treatment Rule
TCEQ	Texas Commission on Environmental Quality
TDS	total dissolved solids
TOC	total organic carbon
TOrC	trace organic constituent (also known as trace organic contaminant)
TSS	total suspended solids
U.S. EPA	United States Environmental Protection Agency
UF	ultrafiltration
UV	ultraviolet
WEF	Water Environment Federation
WRF	Water Research Foundation
WRRF	WateReuse Research Foundation
WWTP	wastewater treatment plant
ZLD	zero liquid discharge

Abbreviations for Units of Measure

A	acre; 43,560 ft ² [(5280 ft/mi) ² /(640 acre/mi ²)]
AF	acre-foot (of water)=325,892 gallons (a unit of water volume used in agricultural irrigation practice)
AF/y	acre-feet per year
ft	foot
gal/capita•d	gallons per capita per day
kg	kilogram=1000 grams
kg CO _{2e} /10 ³ gal	kilogram carbon dioxide equivalent per 1000 gallons
kg CO _{2e} /kWh	kilogram carbon dioxide equivalent per kilowatt hour
km	kilometer
kWh	kilowatt hour
kWh/AF	kilowatt hour per acre-foot
kWh/m ³	kilowatt hour per cubic meter
kWh/10 ³ gal	kilowatt hour per 1000 gallons
L/capita•d	liter per capita per day
m	meter
m ³	cubic meter
MFL	million fibers per liter
mg/L	milligram per liter
Mgal	million gallons
Mgal/d	million gallons per day
mi	mile
mrem	millirem (a unit of radiation, 1000 mrem=1 rem)
ng/L	nanograms per liter=parts per trillion (ppt)
NTU	nephelometric turbidity unit
pCi/L	picocuries per liter (a measure of radioactivity in water)
PFU	plaque-forming units
ppb	parts per billion
ppm	parts per million, ~milligrams per liter (mg/L)
ppt	parts per trillion
rem	roentgen equivalent man (a unit of radiation)
tonne	metric tonne (1000 kg)
µg/L	micrograms per liter=parts per billion (ppb)
µm	micrometer

Useful Terminology

Term	Definition
Advanced treated water (ATW)	Water produced from an advanced water treatment facility for direct and indirect potable reuse applications.
Advanced water treatment	A general term used to describe the overall process and procedures involved in the treatment of wastewater beyond secondary treatment to produce advanced treated water.
Advanced water treatment facility (AWTF)	The treatment facility where advanced treated water is produced. The specific combination of treatment technologies employed will depend on the quality of the treated wastewater and the type of potable reuse (i.e., indirect potable or direct potable reuse).
Barrier	A measure implemented to control microbial or chemical constituents in advanced treated water. A barrier can be technical, operational, or managerial in nature. Log reduction credits are assigned only for technical barriers.
Close-coupled processes	Two or more processes in series where the performance of the first process can affect the performance of the subsequent process or processes.
Concentrate	A liquid waste stream containing elevated concentrations of total dissolved solids and other constituents.
Constituent	Any physical, chemical, biological, or radiological substance or matter found in water and wastewater.
Constituents of emerging concern (CECs)	Chemicals or compounds not regulated in drinking water or advanced treated water. They may be candidates for future regulation depending on their ecological toxicity, potential human health effects, public perception, and frequency of occurrence.
Contaminant	Any physical, chemical, biological, or radiological substance or matter that has an adverse effect on air, water, or soil. The term “constituent” is used in place of “contaminant” in this framework document.
Critical control point (CCP)	A point in advanced water treatment where control can be applied to an individual unit process to reduce, prevent, or eliminate process failure and where monitoring is conducted to confirm that the control point is functioning correctly. The goal is to reduce the risk from pathogen and chemical constituents.
De facto potable reuse	The downstream use of surface water as a source of drinking water that is subject to upstream wastewater discharges (also referred to as “unplanned potable reuse”).

Direct potable reuse (DPR)	There are two forms of direct potable reuse. In the first form, advanced treated water is introduced into the raw water supply upstream of a drinking water treatment facility. In the second form, finished drinking water from an advanced water treatment facility permitted as a drinking water treatment facility is introduced directly into a potable water supply distribution system. The second form of direct potable reuse is not considered in detail in this framework document.
Disinfection byproducts (DBPs)	Chemicals that are formed by the reaction of a disinfectant (e.g., chlorine or ozone) with organic or inorganic matter found in treated water or wastewater.
Drinking water	Water that is supplied to a community for potable uses, including drinking, cooking, bathing, and other household uses, that meets the standards prescribed by the U.S. Environmental Protection Agency’s National Primary Water Regulations (40 CFR Part 141) and any applicable state or local regulations.
Engineered storage buffer (ESB)	A storage facility used to provide retention time—before advanced treated water is introduced into the drinking water treatment facility or distribution system—to (1) conduct testing to evaluate water quality or (2) hold the water in the event that it does not meet specifications.
Environmental buffer	A groundwater aquifer or surface water reservoir, lake, or river into which recycled water is introduced before being withdrawn for potable reuse. In some cases, environmental buffers allow for (1) response time in the event that the recycled water does not meet specifications and (2) time for natural processes to affect water quality. Where tertiary effluent is applied by spreading, the environmental buffer provides both treatment and storage.
Finished water	Water produced by an advanced water treatment facility that also meets all federal, state, and local regulatory requirements for a drinking water treatment plant. Finished water can be introduced directly into a water supply distribution system. Although introduced, this type of “direct” direct potable reuse is not considered in detail in this framework document.
Inactivation	Killing microorganisms or rendering them incapable of reproducing, thereby preventing their ability to cause illness.
Indirect potable reuse (IPR)	The introduction of advanced treated water into an environmental buffer such as a groundwater aquifer or surface water body before being withdrawn for potable purposes (see also “de facto potable reuse”). Indirect potable reuse can also be accomplished with tertiary effluent when applied by spreading (i.e., groundwater recharge) to take advantage of soil aquifer treatment.
Log (base 10) reduction	Log reduction corresponds to a reduction in the concentration of a constituent or microorganism by a factor of 10. For example, a 1-log reduction would correspond to a reduction of 90% from the original concentration. A 2-log reduction corresponds to a reduction of 99% from the original concentration.

Log (base 10) reduction credit	The number of credits assigned to a specific treatment process (e.g., microfiltration, chlorine disinfection, or ultraviolet disinfection), expressed in log units, for the inactivation or removal of a specific microorganism or group of microorganisms. A reduction of 90% would correspond to 1-log credit of reduction, whereas a reduction of 99% would correspond to 2-log credits of reduction.
Nonpotable reuse	A general term for all water reuse applications except those related to potable reuse.
Pathogen	A microorganism (e.g., bacteria, virus, <i>Giardia</i> , or <i>Cryptosporidium</i>) capable of causing illness in humans.
Public outreach	The process of communicating with and educating/informing the public on options and proposed plans for implementing potable reuse projects, as well as receiving input from the public, including questions and concerns that need to be addressed.
Public water system	A system used to provide the public with water for human consumption through pipes or other constructed conveyances, if such system has at least 15 service connections or regularly serves at least 25 individuals; see Section 1401(4)(A) of the Safe Drinking Water Act.
Purified water	Some municipalities use the term “purified water” to refer to advanced treated water, especially in outreach and communication activities.
Redundancy	The use of multiple treatment barriers to attenuate the same type of constituent, so that if one barrier fails, performs inadequately, or is taken offline for maintenance, the overall system still will perform effectively, and risk is reduced.
Relative risk	Estimating the risks associated with a particular event for different groups of people.
Residuals	Waste streams and semisolids produced by wastewater treatment, advanced water treatment, and drinking water treatment processes.
Resilience	The ability to adapt successfully or restore performance rapidly in the face of treatment failures and threats.
Risk	In risk assessment, the probability that something will cause injury combined with the potential severity of that injury.
Robustness	The use of a combination of treatment technologies to address a broad variety of constituents and changes in concentrations in source water.
Safety	Practical certainty that a substance will not cause injury under carefully defined circumstances of use and concentration.
Source control	The elimination or control of the discharge of constituents into a wastewater collection system that can impact wastewater treatment, are difficult to treat, and can impair the final quality of the secondary effluent entering the advanced water treatment facility.

Treatment reliability	The ability of a treatment process or treatment train to consistently achieve the desired degree of treatment, based on its inherent redundancy, robustness, and resilience.
Treatment train	A grouping of treatment technologies or processes to achieve a specific treatment or water quality goal or objective.
Wastewater characteristics	General classes of wastewater constituents, such as physical, chemical, and biological constituents.

Foreword

Prolonged and severe droughts and other factors have made water supplies increasingly scarce in California, Arizona, New Mexico, Texas, many other regions of the United States, and elsewhere around the globe. Based on these conditions, there is a clear need to more effectively use our water resources to provide reliable high-quality potable supplies to our communities. In this context, considerable interest exists in water recycling in general and potable reuse in particular. This framework document provides basic information about potable reuse and the potential value offered by direct potable reuse (DPR). Individual communities can realize numerous advantages – including increasing reliability, lowering carbon footprints, realizing greater value from limited natural supplies, and controlling increases to the cost of water – by considering DPR when building their community water supply portfolios.

This document is the result of a collaborative effort between WateReuse, the American Water Works Association, and the Water Environment Federation with the support of an independent advisory panel (IAP) administered by the National Water Research Institute. The IAP convened over a period of almost two years to give state and other governmental bodies the information they need to make informed decisions on how to pursue a DPR program.

This framework represents a consensus among the IAP, while taking into consideration input from a Project Advisory Committee comprised of technical experts in water and wastewater treatment, as well as state and federal regulators.

Doug Owen

Chair

WateReuse Research Foundation

Melissa Meeker

Executive Director

WateReuse Association and Research Foundation

Robert M. Johnson

President

WateReuse Association

Gene C. Koontz

President

American Water Works Association

David B. LaFrance

Chief Executive Officer

American Water Works Association

Ed McCormick

President

Water Environment Federation

Eileen O’Neill

Executive Director

Water Environment Federation

Preface

Public water supplies in the United States come from a variety of sources (such as groundwater and surface water), but factors like population growth and extended droughts are stressing these supplies in some regions. As a consequence, new strategies are needed to help meet future water demands and develop more sustainable water supplies. One such strategy is planned potable reuse, in which treated wastewater is used to augment public water supplies. Planned potable reuse is the subject of this framework document.

Planned Potable Reuse

At present, planned potable reuse in the United States involves either direct potable reuse (DPR) or indirect potable reuse (IPR).

There are two forms of planned DPR. In the first form, advanced treated water (ATW) produced in an advanced water treatment facility (AWTF) is introduced into the raw water supply immediately upstream of a drinking water treatment facility (DWTF). To date, permitted operational DPR projects in the United States involve the use of this form of DPR.

In the second form of DPR, finished water produced in an AWTF that is also permitted as a DWTF is introduced directly into a drinking water supply distribution system, either downstream of a DWTF or within the distribution system. Because of the many unknowns associated with the management of finished water, this form of DPR will require additional studies to demonstrate the feasibility and safety of the practice; therefore, it is not the focus of this framework document.

In planned IPR projects, ATW or tertiary effluent is introduced into an environmental buffer (e.g., a groundwater basin or surface water reservoir) before being withdrawn for potable purposes. The environmental buffer provides storage, transport, and in some cases an additional barrier for the protection of public health. In groundwater augmentation, ATW can be applied by spreading or direct injection, whereas tertiary effluent is applied by spreading to take advantage of soil aquifer treatment. In surface water augmentation, ATW is added to a surface water reservoir or other water body that serves as the environmental buffer; however, when the volume of the reservoir or other water body does not meet required dilution and storage requirements, the proposed IPR project becomes a DPR project. In the United States and abroad, there are a number of IPR projects in operation. Although IPR is not addressed specifically in this framework document, much of the material presented herein is applicable to IPR.

Unplanned Potable Reuse

Often identified as de facto potable reuse, unplanned potable reuse occurs when downstream surface waters subject to upstream wastewater discharges are used as a source of drinking water. Unplanned potable reuse is a common occurrence in many drinking water supplies derived from surface water supplies, principally rivers, and has been understood for at least 100 years, although the practice is not recognized officially. Unplanned potable reuse is not considered in this framework document.

Purpose of the Framework Document

As interest in potable reuse grows, so does the need for providing guidelines for DPR; however, national guidance or regulations are not expected in the near term. In lieu of such guidance, the purpose of this framework document is to provide an overview of DPR and its essential principles, as well as to identify issues that need to be addressed in the development of DPR guidelines and regulations. Specifically, this framework document can be used to: (1) provide guidance on the key components that make up a DPR program; and (2) assist decision makers in understanding the role DPR projects can play in a community's overall water portfolio. Until guidelines and regulations are prepared, this framework document can serve as a valuable resource to municipalities, utilities, and agencies seeking to implement DPR programs.

Topics Addressed in the Framework Document

The focus of this framework document is on the following three key components of a DPR program:

- Regulatory considerations
- Technical issues related to the production of ATW for potable reuse
- Public outreach

The success of any DPR program will depend on the attention given to each of these key components, which are examined in a series of chapters within this framework document. Because the field of potable reuse is evolving rapidly, an additional chapter is devoted to future developments.

Acknowledgments

This framework document is the product of an Independent Advisory Panel (IAP) administered by the National Water Research Institute, a 501c3 nonprofit based in Southern California. IAP members include:

- Chair: George Tchobanoglous, University of California, Davis
- Joseph Cotruvo, Joseph Cotruvo & Associates
- James Crook, Environmental Engineering Consultant
- Ellen McDonald, Alan Plummer Associates, Inc.
- Adam Olivieri, EOA, Inc.
- Andrew Salveson, Carollo Engineers, Inc.
- R. Shane Trussell, Trussell Technologies, Inc.

Short biographies for the IAP members are included as an appendix in this framework document.

The IAP is pleased to acknowledge the organizations and individuals whose support, assistance, and resources helped make this framework document possible.

Project Supporters

In 2013 the Board of Directors of WateReuse authorized its National Regulatory Committee to undertake a study to assess the status of state regulatory activities and interest in potable reuse—including indirect potable reuse (IPR) and direct potable reuse (DPR)—within their jurisdictions. An ad hoc subcommittee of the National Regulatory Committee developed a survey questionnaire with the support of the Association of Safe Drinking Water Administrators. Thirty state regulatory agencies responded to the questionnaire, and the results demonstrated a need for leadership in providing potable reuse guidance.

In response, the National Water Research Institute, in collaboration with the National Regulatory Committee, proposed a project to WateReuse to coordinate the activities of a panel of national experts to develop a framework document that would:

- Provide an overview of DPR and its essential principles
- Identify issues that need to be addressed in the development of DPR guidelines and regulations
- Serve as a reference for municipalities, utilities, and agencies interested in implementing potable reuse programs until guidance and regulations become available

WateReuse approved funding of the project in 2014. Financial support was also received from the following project partners: American Water Works Association, National Water Research Institute, and Water Environment Federation.

Project Contributors

The IAP process was administered by the National Water Research Institute, which organized the IAP, planned and facilitated IAP meetings in California and Washington, DC, and assisted with the development of this framework document. The IAP recognizes the leadership of Jeffrey Mosher, who was instrumental in moving the project forward and overseeing the IAP effort. We also thank Gina Melin Vartanian and Jeffrey Mosher for their invaluable help in organizing, editing, and formatting the final framework document and its many draft versions. Finally, we acknowledge Brandi Caskey, Suzanne Faubl, and Jaime Lumia for providing administrative support of the IAP process.

The overall project was sponsored and managed by WateReuse under the direction of Melissa Meeker. In particular, the IAP recognizes the outstanding services of Justin Mattingly, who served as project manager and administered both the project and its Project Advisory Committee (PAC). We also appreciate the direction and support provided by the PAC, which reviewed a number of draft versions of the framework document. Its input added tremendous value to the final document. Members of the PAC include:

- Katherine Y. Bell, MWH Global
- Erica Brown, Association of Metropolitan Water Agencies
- Margaret H. Nellor, Nellor Environmental Associates, Inc.
- Philip Oshida, U.S. Environmental Protection Agency, Office of Groundwater and Drinking Water
- Valerie Rourke, Virginia Department of Environmental Quality
- Steve Via, American Water Works Association

Finally, the IAP thanks the following individuals who, through their peer review comments, enhanced the framework document in many ways:

- Takashi Asano, University of California, Davis
- William Dunivin, Orange County Water District
- Robert Hultquist, California State Water Resources Control Board
- Desmond Lawler, University of Texas at Austin
- Harold Leverenz, University of California, Davis
- Benjamin Stanford, Hazen and Sawyer
- R. Rhodes Trussell, Trussell Technologies, Inc.
- Troy Walker, Hazen and Sawyer

Chapter 1

Introduction

Water supplies in the United States are derived from a variety of sources, including local and imported surface water, groundwater, desalinated brackish water and seawater, and recycled water. As a result of population growth, urbanization (especially along coastal regions), cyclical droughts, and climate change, public water supplies in some regions are becoming stressed, and the opportunity to develop new groundwater or surface water sources is becoming more difficult, if not impossible. Although conservation can reduce per capita demand, the remaining supplies may be insufficient to meet overall water needs. As a consequence, new strategies are needed to help meet future water demands and develop more sustainable water supplies. One such strategy is planned potable reuse, in which treated wastewater is used to augment public water supplies. Planned potable reuse is the subject of this framework document. As an introduction, the following topics are addressed in this chapter:

- What is the difference between planned and unplanned potable reuse?
- Why is potable reuse guidance needed?
- What is the purpose of this framework document?
- What is the organization of this framework document?

1.1 Overview of Potable Reuse

Potable reuse involves the use of a community's wastewater as a source of drinking water. Planned and unplanned potable reuse both occur in the United States today. These forms of potable reuse, along with the role of potable reuse in a community's water supply, are described in Sections 1.1.1 to 1.1.3.

1.1.1 Planned Potable Reuse

Two forms of planned potable reuse exist: (1) *direct potable reuse (DPR)*, in which highly treated wastewater is introduced at various locations into an existing water supply system; and (2) *indirect potable reuse (IPR)*, in which treated wastewater is introduced into an environmental buffer (e.g., a groundwater aquifer or surface water reservoir, lake, or river) before the blended water is introduced into a water supply system. DPR and IPR are described in detail in Chapter 2.

1.1.2 Unplanned Potable Reuse

Often identified as de facto potable reuse, unplanned potable reuse occurs when downstream surface waters subject to upstream wastewater discharges are used as a source of drinking water. Unplanned potable reuse is a common occurrence in a number of drinking water supplies derived from surface water sources, principally rivers (NRC, 2012), and has been understood for at least 100 years, including how to address its issues and challenges (Hazen,

1914); however, the practice is not recognized officially (U.S. EPA, 2012). Unplanned potable reuse is not addressed in this framework document.

1.1.3 The Role of Planned Potable Reuse in a Community’s Water Supply

Because of indoor and outdoor water use and other nonresidential municipal consumptive uses, neither DPR nor IPR can replace all current potable water demands, nor can all collected wastewater be used as part of a potable reuse project. For example, based on a recent estimate for California, roughly 30% of all wastewater collected—or about 50% of the water now discharged to the ocean—could be used by 2020 for either DPR or IPR projects (Raucher and Tchobanoglous, 2014). The actual amount of water available will vary by region, depending on site-specific factors such as the effluent discharge location.

1.2 Need for Direct Potable Reuse Guidance

As interest in potable reuse has grown, so has the need for providing guidelines for DPR; however, national guidance or regulations are not expected in the near term. When state regulators and decision makers for local governments and water utilities are required to make significant water supply decisions without specific criteria or guidance, the decisions made may not be representative of the state of the art or may include excessive treatment complexities and redundancies that impede or slow down the implementation of projects. Such decisions may also result in higher project costs and delays, as well as confusion and skepticism among regulators and the public.

Given the number of questions that must be considered to implement DPR, WateReuse and National Water Research Institute (NWRI), in cooperation with the American Water Works Association (AWWA) and Water Environment Federation (WEF), supported the activities of an Independent Advisory Panel (IAP) to identify issues that need to be addressed in the development of DPR guidelines, which could lead, ultimately, to regulations. The result of the IAP effort is the development of this framework document.

1.3 Purpose of the Framework Document

The purpose of this document is to provide a detailed framework that can be used in the development of guidelines for the implementation of DPR. Because DPR is intended to augment existing drinking water supplies that are already subject to federal and state drinking water regulations, the focus of this document is on the following:

- Provide a discussion of the guidance needed for each of the three key components (regulatory, technical, and public outreach) that make up a DPR program, as described in Table 1.1
- Assist decision makers in understanding the role DPR projects can play in the overall water portfolio of a community

Each issue identified in Table 1.1 is addressed in detail throughout this framework document. Although DPR is the subject of this document, many of the key aspects presented and discussed herein can also be applied to IPR; accordingly, relevant aspects of IPR are also discussed.

Table 1.1. Guidance Needed for the Three Key Components of a DPR Program

Key Component	Issue in Need of Guidance
Regulatory	<ul style="list-style-type: none">• Potential public health risks and measures to mitigate these risks.• Elements of the regulatory permitting process.• Operator training requirements and certification.
Technology	<ul style="list-style-type: none">• Treatment technologies and their performance capabilities for the production of ATW that are protective of public health.• Treatment performance through operational and treatment reliability, water quality (i.e., monitoring), operation and maintenance programs, source control programs, and residuals management .• Appropriate multiple treatment barriers, including technical, operational, and management barriers.• Issues associated with blending ATW with other water sources.
Public outreach	<ul style="list-style-type: none">• Purpose for communicating with and engaging community stakeholders and the public on the DPR project.• Goals and challenges of outreach specific to DPR.• Planning tools, materials, and support for an effective DPR outreach program.

Notes: ATW=advanced treated water; DPR=direct potable reuse.

1.4 Organization of the Framework Document

This framework document is organized into the following chapters:

1. Introduction
2. What Is Direct Potable Reuse?
3. Key Components of a Successful/Sustainable DPR Program
4. Public Health and Regulatory Aspects
5. Source Control Program
6. Wastewater Treatment
7. Advanced Water Treatment
8. Management of Advanced Treated Water
9. Process Monitoring
10. Residuals Management
11. Facility Operation
12. Public Outreach
13. Future Developments

An overview of DPR is presented in Chapters 2 and 3; it is intended to serve as a general introduction to potable reuse (more specifically, DPR) and the chapters that follow. Regulatory issues are addressed in Chapter 4. Technical issues associated with the

implementation of a DPR program are addressed in Chapters 5 through 11. Public outreach is addressed in Chapter 12. Because technology is evolving rapidly, the final chapter is devoted to future needs to: (1) reduce the potential for overly conservative designs in the early implementation of potable reuse projects; and (2) develop the information necessary to allow for permitting advanced water treatment facilities (AWTFs) to provide finished water that can be introduced directly into drinking water distribution systems.

1.5 References

Hazen, A. *Clean Water and How to Get It*, 2nd ed.; John Wiley & Sons: New York, 1914.

NRC. *Water Reuse: Potential for Expanding the Nation's Water Supply through Reuse of Municipal Wastewater*. National Research Council, National Academies Press: Washington, DC, 2012.
http://www.nap.edu/catalog.php?record_id=13303 (accessed 9/3/2015)

Raucher, R.; Tchobanoglous, G. *The Opportunity and Economics of Direct Potable Reuse*, WaterReuse Research Foundation: Alexandria, VA, 2014.

U.S. EPA. *Guidelines for Water Reuse*. EPA/600/R12/618, Office of Wastewater Management: U.S. Environmental Protection Agency: Washington, DC, 2012.
<http://nepis.epa.gov/Adobe/PDF/P100FS7K.pdf> (accessed 9/3/2015)

Chapter 2

What Is Direct Potable Reuse?

Planned potable reuse involves the treatment of a community's wastewater with the express purpose of converting it into a source of drinking water. As introduced in Chapter 1, two forms of planned potable reuse occur: direct potable reuse (DPR) and indirect potable reuse (IPR). Municipalities, utilities, and agencies interested in potable reuse will need to understand the following topics addressed in this chapter.

- What is DPR?
- What is IPR?
- What is required to allow treated wastewater to be considered a new raw water source?
- What example DPR projects are available?
- What does DPR cost?
- What are the energy requirements of DPR?
- What are the comparative issues with other water sources and measures?

2.1 Direct Potable Reuse

There are two forms of DPR in use today: one involves advanced treated water (ATW), and the other involves finished water. Both forms are illustrated in Figure 2.1, as follows:

- In Figure 2.1(a), ATW is introduced with or without the use of an engineered storage buffer (ESB) into the raw water supply immediately upstream of a drinking water treatment facility (DWTF). To date, permitted operational DPR projects in the United States involve this form of DPR.
- In Figure 2.1(b), finished water is directly introduced—with or without the use of an ESB—into a drinking water supply distribution system, either downstream of a DWTF or within the distribution system. A finished water DPR project has been in operation at Windhoek, Namibia, since 1967.

Further details about the differences in these forms of DPR, including treatment trains with and without ESBs, are provided in Sections 2.1.1 to 2.1.4.

2.1.1 Introduction of Advanced Treated Water Upstream of a Drinking Water Treatment Facility

When introduced upstream of a DWTF [see Figure 2.1(a)], ATW becomes essentially another source of raw potable water. ATW typically meets all drinking water standards and regulations; however, it cannot be introduced directly into the distribution system as finished water if it was not produced in a facility permitted as a DWTF.

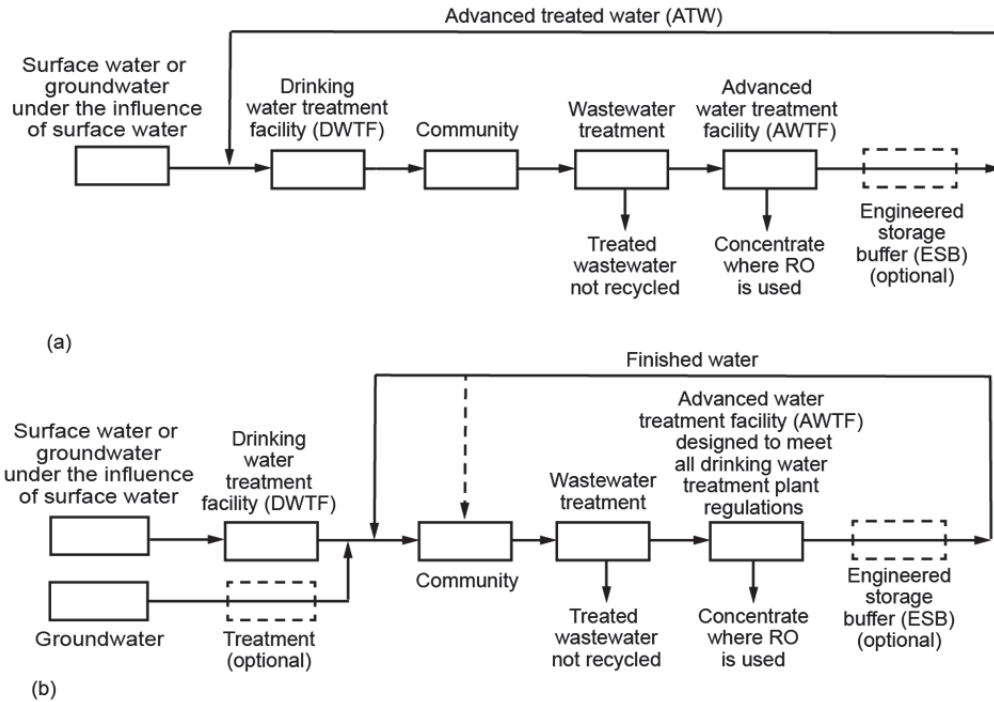

Figure 2.1. Flow diagrams for DPR: (a) with ATW introduced upstream of a DWTF; and (b) finished water introduced into the drinking water supply distribution system downstream of a DWTF.

When ATW is introduced upstream of a DWTF, the DWTF serves as an additional treatment barrier to provide an added factor of safety. In some cases, it may be necessary to use the disinfection credit available for water treatment per the Surface Water Treatment Rule (SWTR) of the Safe Drinking Water Act (SDWA) to meet required microbial log reduction objectives for DPR (see discussions in Chapters 4 and 7).

2.1.2 Treatment Train with an Engineered Storage Buffer

An engineered storage buffer (ESB), shown as a dashed box in Figure 2.1(a), may be used before the ATW is introduced upstream of a DWTF. If used, the purpose of the ESB is to provide a water storage containment facility of sufficient volumetric capacity to retain ATW for a specified time period (Tchobanoglous et al., 2011).

To ensure that the quality of the ATW meets all applicable water quality-related public health standards or quality measures prior to being introduced into a DWTF, the amount of time required to hold the ATW in the ESB should be sufficient to allow for flow continuity and the measurement and reporting of specific constituents. This definition does not mean that all regulatory standards must be monitored in the ESB prior to the release of the ATW; rather, it provides an opportunity to monitor for select key performance parameters. The use of an ESB is critical when the advanced water treatment facility (AWTF) does not have (1) redundancy or critical treatment processes that are monitored routinely (e.g., daily) and (2) online metering that can be used to monitor treatment performance accurately.

2.1.3 Treatment Train without an Engineered Storage Buffer

When an ESB is not used, as represented by the dashed box in Figure 2.1(a), the AWTF should have the following: (1) redundant treatment to allow for the continuous production (or retreatment or discharge) of ATW if one of the major treatment processes is out of specification; and (2) effective monitoring to demonstrate sufficient treatment protective of public health (see Chapter 7).

2.1.4 Direct Introduction of Finished Water into the Drinking Water Supply Distribution System

Finished water, produced in an AWTF that is also permitted as a DWTF (i.e., a facility that meets all federal, state, and local regulations), is introduced directly into the drinking water distribution system, as shown in Figure 2.1(b). The drinking water in the distribution system can be (1) treated surface water or (2) treated or untreated groundwater, which may or may not be disinfected. At this time, questions remain about the issues associated with blending different drinking waters and finished water, as well as the blending location.

The rationale for the use of an ESB with finished water is the same as that for ATW, as discussed in Section 2.1.2. Bypassing the DWTF could be done only with appropriate monitoring and response time procedures. In the future, as monitoring technologies become more sensitive for the measurement of critical constituents of concern (COCs), it is likely that the DWTF will be bypassed, assuming all public health and monitoring requirements are being met and the AWTF is also permitted as a DWTF. Because of the many unknowns associated with the management of finished water, this form of DPR will require additional studies to demonstrate the feasibility and safety of the practice; therefore, it is not the focus of this framework document.

2.2 Indirect Potable Reuse

In an IPR process, ATW or tertiary effluent is introduced into an environmental buffer before being withdrawn for potable purposes. The purpose of the environmental buffer is to provide storage, transport, and, in some cases, an additional barrier for the protection of public health; however, the environmental storage of highly treated water, if not stabilized or mixed with other water, can also add contaminants and degrade the water (e.g., dissolution of metals from the groundwater aquifer or microbial and other contaminants in surface impoundments).

In Figure 2.2(a), the environmental buffer is a groundwater aquifer. ATW can be applied by spreading or direct injection, whereas tertiary effluent is applied by spreading to take advantage of soil aquifer treatment. Planned IPR through the recharge of groundwater aquifers has been practiced in California since 1962 (Crook, 2010).

In Figure 2.2(b), a surface water reservoir or other water body serves as the environmental buffer. Planned augmentation of a surface water source with treated wastewater has been practiced in Fairfax County, VA, since 1978 (UOSA, no date). It is also important to note that when the volume of the reservoir or other water body does not meet required dilution and storage requirements, the proposed IPR project [see Figure 2.2(b)] becomes a DPR project [see Figure 2.1(a)].

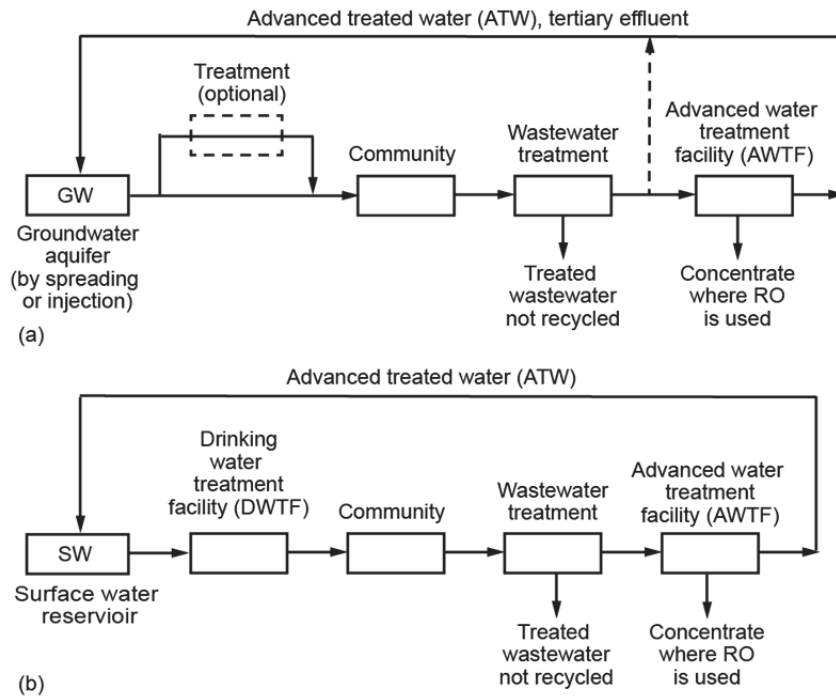

Figure 2.2. Flow diagrams for IPR: (a) with a groundwater aquifer as an environmental buffer; and (b) with a surface water reservoir as an environmental buffer.

2.3 New Raw Potable Water Source (Advanced Treated Water)

Treatment technologies capable of producing ATW that meets all drinking water standards have been demonstrated in numerous investigations and AWTFs. In general, where reverse osmosis (RO) is used, the ATW is of higher quality than most conventional treated drinking waters with respect to total organic carbon (TOC) and total dissolved solids (TDS), as well as trace contaminants; however, regulators, public health professionals, and practitioners have not reached consensus as to the appropriate framework and governing parameters for potable reuse.

Recognizing that there may be potential issues that require careful examination, it is reasonable to propose consideration of ATW as a source for drinking water supply along with surface water and groundwater. The regulation of ATW as a third water source is considered further in Chapter 4.

2.4 Examples of Direct Potable Reuse Projects

Three examples of DPR projects currently in operation or under design/construction are reviewed briefly in Table 2.1.

Notably, the treatment process flow diagrams and treatment technologies used for these projects have been accepted by various regulatory authorities as being able to reliably produce a safe drinking water source. Furthermore, the DPR projects presented in Table 2.1 have been accepted by the public.

Table 2.1. Examples of DPR Projects

Entity	Description
Wichita Falls, TX (emergency water supply)	Chlorinated secondary effluent is treated with MF, RO, and UV disinfection, and then blended 50/50 with other raw water supplies (see Figure 2.1a) before being treated at the city’s DWTF. The project began operation in July 2014 and was implemented on an emergency basis in response to severe drought conditions. The MF/RO advanced treatment system was installed originally to treat a brackish surface water source and will be converted back to this use in the future (Nix, 2015). Following significant rainfall events in 2015, the facility has been taken offline.
Colorado River Municipal Water District Raw Water Production Facility, Big Spring, TX	Filtered secondary effluent is treated with MF, RO, and UV-AOP. The treated water is blended with raw water in a transmission line (see Figure 2.1a). The blended water is then treated in one of several DWTFs before distribution. The DPR process has been operational since spring 2013 (Livingston and Salveson, 2008; Salveson et al., 2015).
Windhoek, Namibia	Starting in 1968, reclaimed water was added to the drinking water supply system. The plant was upgraded in 1997, and the blending of finished water (without RO treatment) with other drinking water occurs directly in the pipeline that feeds the drinking water distribution network (see dashed line in Figure 2.1b; du Pisani, 2005; Lahnsteiner and Lempert, 2005).

Notes: AOP=advanced oxidation process; DPR=direct potable reuse; DWTF=drinking water treatment facility; MF=microfiltration; RO=reverse osmosis; UV=ultraviolet.

Source: Adapted from Raucher and Tchobanoglous (2014).

2.5 Cost of Direct Potable Reuse

Cost is an important consideration in evaluating new water supply alternatives, especially for DPR projects. In many cases, the costs of DPR compare favorably with the costs of other new sources of water. The cost for DPR is made up of the costs of the following elements:

- Advanced water treatment.
- ESB (if used).
- Residuals management.
- Concentrate management when RO is employed as part of the treatment train.
- Conveyance.

Comparative unit costs for DPR and other water supply options are presented in Table 2.2 and discussed in Sections 2.5.1 to 2.5.5. The unit costs include both annualized capital costs and operation and maintenance (O&M) costs. The reported unit cost ranges reflect site-specific conditions, different plant capacities, and the use of different economic criteria for the calculation of annualized capital cost.

Table 2.2. Comparative Unit Costs of Advanced Treated Water, Brackish and Seawater Desalination, and Conservation Measures

Supply Option	Cost \$/10 ³ gal (\$/AF) ^a			
	Treatment	Residuals Management	Concentrate Management ^b	Conveyance and Blending Facilities ^b
AWTF with RO	2.10–2.76 (685 ^c –900)	0.03–0.15 (10–50)	0.21–2.38 (70–775) ^d	0.31–3.07 (100–1000)
AWTF without RO	1.23–2.15 (400–700)	0.03–0.15 (10–50)	Not applicable	0.31–3.07 (100–1000)
Brackish groundwater desalination (inland)	1.23–2.45 (400–800)	0.02–0.06 (5–20)	0.21–2.38 (70–775) ^d	0.31–3.07 (100–1000)
Seawater desalination	5.98–10.74 (1950–3500)	0.06–0.31 (20–100)	0.21–0.61 (70–200)	1.23–9.21 (100–3000)
Retail cost of treated imported surface water	1.23–3.99 (400–1300)		Not applicable	0.31–1.84 (100–600)
Water use efficiency, conservation, and use restrictions	1.38–2.92 (450–950)			Not applicable

Notes: ^aThe reported costs are based on an Engineering News Record Construction Cost Index of 9900 (value of index in 1913=100). ^bThe costs for RO concentrate or brine management and conveyance are site specific and will vary widely. ^cBased on actual costs from OCWD for the original AWTF. The estimated cost for the new plant expansion, including influent flow equalization, is \$2.15/10³ gal (\$701/AF; see Table 2.3 and Figure 2.3). ^dSee Table 10.3 in Chapter 10; (\$/10³ gal) × 325.892 = \$/AF; (\$/10³ gal) × 0.264 = \$/m³. AWTF=advanced water treatment facility; RO=reverse osmosis.

Source: Adapted in part from Raucher and Tchobanoglous (2014).

2.5.1 Cost of Treatment

As reported in Table 2.2, the treatment costs for the production of ATW are based on actual and projected costs for an AWTF with a capacity of 5 Mgal/d or greater. Treatment costs for smaller facilities are difficult to estimate because they are site specific, and economies of scale generally do not apply.

The lowest cost of \$685/ AF (\$2.1/10³ gal) for ATW, as footnoted in Table 2.2, is based on the actual unsubsidized cost of the original 70 Mgal/d AWTF for the Groundwater Replenishment System (GWRS), an IPR project operated continuously since January 2008 by the Orange County Water District (OCWD). An additional 30 Mgal/d of capacity came online in June 2015. The treatment technologies employed for the production of ATW at the original and expanded facilities at OCWD are reported in Table 2.3 and illustrated in Figure 2.3. These processes are considered in detail in Chapter 7.

Table 2.3. Summary of Treatment Technologies Employed for the Production of ATW at OCWD

Treatment Technology	OCWD Original ^a	OCWD Expansion ^b
Filter screens	✓	✓
Influent flow equalization		✓
Microfiltration	✓	✓
Cartridge filtration	✓	✓
Reverse osmosis	✓	✓
Advanced oxidation	✓	✓
Decarbonation	✓	✓
Lime stabilization	✓	✓

Notes: ^aCapacity of the original AWTF is 70 Mgal/d of ATW.

^bCapacity of the expansion AWTF is 30 Mgal/d of ATW.

See also Figure 2.3.

Source: Raucher and Tchobanoglous (2014).

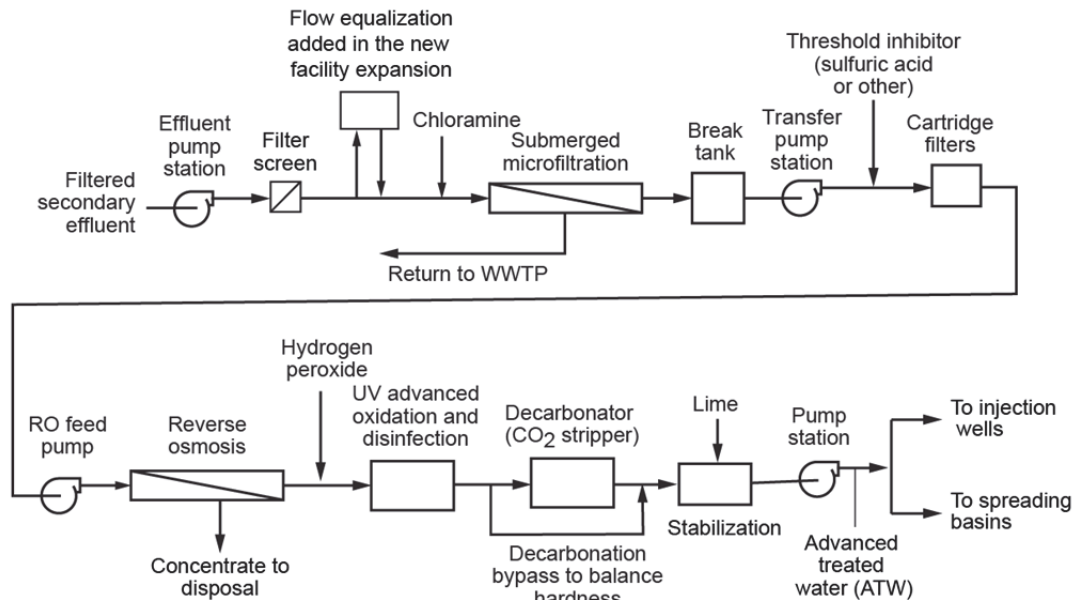

Figure 2.3. Flow diagram for the AWTF at OCWD.

Note: Flow equalization was not included in the original flow diagram, but was added when the capacity of the facility was increased from 70 to 100 Mgal/d.

Because of the successful long-term operation of the AWTF at OCWD, the combination of treatment processes employed at OCWD to produce ATW is used often as the default treatment train for potable reuse applications. It is important to note, however, that a number of agencies have conducted or are conducting studies to demonstrate that non-RO technologies may be suitable to produce ATW where RO concentrate disposal is a barrier to DPR implementation. The projected base cost of advanced water treatment for an AWTF employing RO is assumed to be the same as that for OCWD because additional treatment units will not be required and OCWD has undertaken more monitoring than will be required for future AWTFs. Projected costs for advanced water treatment without RO are also included in Table 2.2.

2.5.2 Cost of the Engineered Storage Buffer

Costs for an ESB facility also are site specific and will depend on the volumetric capacity, configuration, construction materials, fittings and accessories, and degree of instrumentation. Configurations for an ESB can include plug-flow pipelines, baffled tanks, or tanks in parallel operated in a fill, storage, and draw mode. Typical capital costs for a three-tank ESB facility with an 8 hour failure response time (FRT) (see Chapter 7) can vary from \$2.50/gal for a flow rate of 5 Mgal/d to \$1.25/gal for a flow rate of 20 Mgal/d or greater. The corresponding unit costs, which include capitalized costs (based on a 30 year amortization period and an interest rate of 2.5%) and O&M, are estimated to be \$0.26 and \$0.18/10³ gal, respectively.

2.5.3 Cost of Residuals Management

With the exception of RO concentrate, the liquid and semisolid residuals resulting from treatment usually are recycled to either the wastewater treatment plant (WWTP) or the headworks of the AWTF. The reported cost range for residual management depends on how the costs are allocated (e.g., charged against the WWTP or AWTF).

2.5.4 Cost of Reverse Osmosis Concentrate Management

The costs for RO concentrate management are site specific and vary widely depending on the characteristics and volume of concentrate that must be managed and the disposal method. An extensive discussion of RO concentrate management is presented in Chapter 10. The low end of the cost, \$0.21/10³ gal (\$70/AF), is based on disposal by deep well injection. The high-end cost of \$2.38/10³ gal (\$775/AF) is based on zero liquid discharge (ZLD) using energy-intensive processes to produce a dry product that can be disposed of in a landfill. The cost for the disposal of RO concentrate using an existing deep water ocean outfall is typically in the range of \$0.35 to \$0.38/10³ gal (\$115 to \$125/AF).

2.5.5 Cost of Conveyance

Conveyance costs will vary with siting opportunities for AWTFs. The conveyance cost for OCWD's IPR project, in which ATW is transported by pipeline 13 miles to spreading basins, is \$0.37/10³ gal (\$120/AF). Conveyance costs for some IPR projects in the planning and development stage vary from \$0.31 to more than \$3.07/10³ gal (\$100 to more than \$1,000/AF).

2.6 Energy Requirements for Direct Potable Reuse

The energy required for DPR is made up of the energy requirements for: (1) advanced water treatment; (2) conveyance; and (3) RO concentrate management. Each of these energy requirements is considered in Sections 2.6.1 to 2.6.3.

2.6.1 Energy Requirements for the Production of Advanced Treated Water

The overall energy requirements for secondary and advanced water treatment, brackish and seawater desalination, imported water, and conventional and membrane-based water treatment are reported in Table 2.4, along with corresponding carbon footprint values.

As shown, the energy required to produce ATW will vary from 3.25 to 3.5 kWh/10³ gal (1,050 to 1,140 kWh/AF) beyond that needed for secondary treatment, depending on the TDS in the wastewater. The lowest value for energy usage (3.25 kWh/10³ gal) for ATW, as footnoted in Table 2.4, is based on actual operating experience at OCWD's original AWTF. By comparison, seawater desalination (with energy recovery) requires about 9.5 to 14.75 kWh/10³ gal (3,100 to 4,810 kWh/AF). Inter-basin transfers of water often can require large expenditures of energy to pump water over the watershed divides that separate and define the basins.

The carbon footprint values associated with the energy required for various technologies and water sources are presented in Table 2.4. The carbon footprint reflects the carbon dioxide emission equivalents released in the production of a kilowatt hour of energy, which will vary by state depending on the mix of energy sources. In the United States, the baseload range across the Emissions and Generation Resource Integrated Database (eGRID) regions varies from 0.20 to 0.86 kg CO₂e/kWh; the non-baseload range is from 0.42 to 0.94 kg CO₂e/kWh. For purposes of comparison, the reported values were computed using a conversion factor of 0.50 kg CO₂e/kWh.

2.6.2 Energy Requirements for Conveyance

The energy requirements for conveyance are site specific and will depend on the total dynamic head for the conveyance system, properties of the fluid being pumped, and efficiency of the pumping equipment. The energy requirements for the support equipment and facilities must also be taken into account.

For example, for an ATW flow rate of 17.9 Mgal/d or 27.7 ft³/s (20,000 AF/y), the energy required for conveyance for every 10 feet of total dynamic head (static head plus dynamic losses) is equal to 41.9 horsepower or 31.3 kilowatts (kW), which corresponds to 0.042 kWh/10³ gal (13.7 kWh/AF). The computed value is based on the assumption that the specific weight of the ATW at 20°C is 62.3 lb/ft³ and the pump efficiency is 75%. If the total dynamic head is 250 feet (which is not uncommon), then the corresponding value would be 1.05 kWh/10³ gal (342 kWh/AF). The energy required for conveyance can clearly become significant (Raucher and Tchobanoglous, 2014).

Table 2.4. Comparative Energy Requirements for Wastewater and Water Treatment, Advanced Water Treatment, and Alternative Sources of Surface Water

Technology/Water Source	Energy Required			Carbon Footprint (kg CO _{2e} /10 ³ gal)
	Range (kWh/10 ³ gal)	Typical ^a		
		kWh/10 ³ gal	kWh/m ³	
Secondary treatment without nutrient removal ^{b,c}	1.40–1.05	1.25	0.33	0.63
Tertiary treatment with nutrient removal and effluent filtration ^{b,c}	1.95–1.60	1.85	0.49	0.93
AWTF	4.00–3.25 ^d	3.60	0.95	1.80
Brackish water desalination ^e	3.10–6.20	5.85	1.55	2.93
Ocean desalination ^e	9.50–14.75	12.00	3.17	6.00
Interbasin transfer of water, California State Water Project ^f	7.92–9.92	9.20	2.43	4.60
Interbasin transfer of water, Colorado River water ^g	6.15–7.40	6.15	1.62	3.07
Conventional water treatment ^h	0.30–0.40	0.37	0.10	0.19
Membrane-based water treatment ⁱ	1.00–1.50	1.25	0.33	0.63

Notes: ^aTypical energy values are for WWTPs and DWTFs with an average design flow of 10 Mgal/d. ^bEnergy recovery is not included. ^cThe range of energy consumption values is for a 5 and 100 Mgal/d treatment plant, respectively. ^dBased on actual operating records from OCWD for the original AWTF (see Table 2.3 and Figure 2.3). ^eEnergy required for distribution is not included. ^fEnergy required, including energy recovery, for delivery to the point of treatment (Southern California)—the energy required for treatment and distribution is not included, and the difference in energy values depends on the point of water delivery. ^gEnergy required for delivery to the point of treatment (Southern California), not including treatment and distribution—the difference in energy values depends on the point of water delivery. ^hRaw water pumping, rapid mix, coagulation, flocculation, sedimentation, filtration, and disinfection (finished water pumping is not included). ⁱRaw water pumping, rapid mix, chemical feed, dissolved air flotation, ultrafiltration, and disinfection (finished water pumping is not included). (kWh/m³)×3.785=kWh/10³ gal; (kWh/10³ gal)×325.892=kWh/AF; (kWh/10³ gal)×0.5=CO_{2e}/10³ gal. AWTF-advanced water treatment facility.

Sources: Adapted in part from Larson et al. (2007); Taffler et al. (2008); WEF (2009); Stillwell et al. (2010); EPRI (2013); and Raucher and Tchobanoglous (2014).

2.6.3 Energy Requirements for Reverse Osmosis Concentrate Management

The energy requirements for RO concentrate management are site specific and more difficult to generalize than conveyance costs. For example:

- If it is assumed that the percentage of concentrate from an RO treatment process with a product water flow of 17.9 Mgal/d or 27.7 ft³/s (20,000 AF/y) is 15%, then the amount of concentrate that must be disposed of per year would be 3.1 Mgal/d $\{[(17.9 \text{ Mgal/d})/0.85] - [(17.9 \text{ Mgal/d})]\}$ or (3,530 AF/y).
- If the weight of the RO concentrate at 20°C is 63.0 lb/ft³, total dynamic head is 30 feet, and pump efficiency is 75%, then the energy required for discharge through an ocean outfall is about 0.127 kWh/10³ gal (41.1 kWh/AF), based on product water production.

2.7 Comparative Issues with Other Water Sources and Measures to Direct Potable Reuse

When determining whether to proceed with a DPR program, it is useful to compare the issues associated with developing and implementing DPR, as discussed in this chapter, to the issues associated with developing and implementing alternative water sources and measures. Comparative issues are reviewed in Table 2.5 with respect to the following: (1) imported surface waters; (2) desalination; (3) IPR; (4) centralized nonpotable reuse (C-NPR); (5) decentralized nonpotable reuse (D-NPR); and (6) conservation and curtailments. The relative importance of these issues will depend on local conditions.

Table 2.5. Comparative Issues with Alternative Sources of Water and Other Water Management Measures to DPR

Imported Waters
<ul style="list-style-type: none">• New sources of imported water are difficult, if not impossible, to develop.• Withdrawing water from inland areas, transporting it to population centers, treating and using it once, and discharging it to coastal waters is, in the long term, less sustainable than other options.• Imported water sources: (1) are subject to natural and institutional disruptions and limitations, resulting in potentially large interannual variability; (2) can be of variable quality (e.g., high salt load); (3) often require significant amounts of energy for transport; (4) can impose significant adverse environmental consequences when local water is extracted; (5) reduce potential environmental impacts of wastewater discharges to surface waters; and (6) are relatively expensive, the cost of which will continue to escalate in the future.• Imported water is also subject to natural and societal forces that are difficult to control, including: (1) increased demands from population growth; (2) drought; (3) changes in snowpack, rainfall, or other natural sources of replenishment; (4) seismic events; and (5) future environmental regulations, water rights determinations, and associated legal challenges.• In many locations, imported water increases local salt loading.• Extensive treatment may be required for low-quality imported water sources.

Desalination

- Ocean desalination is a technically feasible option that can provide a high-quality, potable supply after blending or chemical addition, but with a number of drawbacks, including:
 - Potential environmental impacts associated with ocean feed water intakes, brine disposal and discharges, and construction of facilities at sensitive shoreline or near-shore locations.
 - Relatively high energy demands and carbon footprints.
 - Red tides and other ocean water quality challenges.
 - Coastal facilities that may be vulnerable to sea level rise and storm surges.
- Inland brackish water desalination is less costly than ocean desalination because of much lower salt content, but has significant brine management challenges.
- Ocean desalination facilities in the United States are subject to regulatory requirements.
- Ocean desalination is more expensive than potable reuse, often by a factor of 2:1 per gallon.
- When desalinated source water is recycled, it increases the amount of water available for local beneficial use.

Indirect Potable Reuse

- An environmental buffer provides benefits such as storage, retention time, and additional treatment. It may increase public favor for IPR over DPR.
- In some locations, the lack of surface or groundwater buffers prohibits IPR, but allows DPR.
- Degradation or contamination of ATW could occur when it is released into the environmental buffer.
- Significant costs are associated with protecting, maintaining, operating, and monitoring environmental buffers.
- Water rights issues may arise when water is placed into an environmental buffer.
- De facto potable reuse occurs when downstream surface waters, subject to upstream wastewater discharges, are used as a source of drinking water.

Centralized Nonpotable Reuse (C-NPR)

- Typically, water for C-NPR applications does not need to be treated to the same level as for DPR.
 - Separate distribution systems require a significant investment in pipes and pumps, and O&M (often for small amounts of recycling) is not required for IPR or DPR.
 - Because many C-NPR demands are seasonal (e.g., golf course watering), water recycling assets are underused part of each year. Storage needs to be created to match year-round production with part-year demands.
 - Implementing C-NPR or IPR entails some disruption and costs associated with the construction of large-scale pipeline projects.
 - The potential for cross-connections always exists with dual water systems, along with the attendant costs of prevention and correction.
-

Decentralized Nonpotable Reuse (D-NPR)

- D-NPR includes graywater systems, rainwater capture systems, and decentralized treatment plants.
- Satellite wastewater treatment plants can be used for local applications (e.g., greenbelt watering).
- Even if D-NPR systems are implemented, homeowners must still pay for community water system infrastructure costs.
- Unless an entire area is converted to D-NPR, the quantities of water recycled will be small compared to the potential for C-NPR, IPR, or DPR.
- Based on detailed cost analyses, C-NPR is more cost effective than individual home D-NPR.
- Financing will be difficult for individual home D-NPR systems.
- The potential for cross-connections and less reliable maintenance always exists with separate water systems.

Conservation and Curtailments

- Significant per capita water use reductions have been realized in residential, commercial, and industrial settings through past efforts to educate water users and incentivize water savings through rebates and other mechanisms. Although additional water conservation measures will continue to reduce water demand, the cost per volume of water saved will increase steadily.
- Code-required proliferation of water-saving appliances, such as low-flush toilets, has systematically contributed to lower water consumption rates in municipalities and reduced consumer water costs; however, reduced consumption may trigger higher water rates for cost recovery.
- Typical costs estimated for conservation efforts are only those expenses borne by the community water utility; the costs borne directly and indirectly by customers investing in water-saving appliances or forgoing lawns and gardens are not factored into overall cost estimates.

Notes: ATW=advanced treated water; DPR=direct potable reuse; IPR=indirect potable reuse; O&M=operations and maintenance.

Source: Adapted in part from Raucher and Tchobanoglous (2014).

2.8 References

Crook, J. *Regulatory Aspects of Direct Potable Reuse in California*. National Water Research Institute: Fountain Valley, CA, 2010.

<http://nwri-usa.org/pdfs/NWRIPaperDirectPotableReuse2010.pdf> (accessed 9/3/2015)

du Pisani, P. L. Direct Reclamation of Potable Water at Windhoek's Goreangab Reclamation Plant. In Khan, S. J.; Muston, M. H.; Schafer, A. I., eds.; *Integrated Concepts in Water Recycling*. University of Wollongong: New South Wales, Australia, 2005.

EPRI. *Electricity Use and Management in the Municipal Water Supply and Wastewater Industries*. Electric Power Research Institute: Palo Alto, CA, 2013.

- Lahnsteiner, J.; Lempert, G. Water Management in Windhoek, Namibia. In *Proceedings of the IWA Conference, Wastewater Reclamation & Reuse for Sustainability*, Jeju, Korea, 2005.
- Larson, D.; Lee, C.; Tellinghuisen, S.; Keller, A. California's Energy–Water Nexus: Water Use in Electricity Generation. *Southwest Hydrol.* **2007**, *6* (5), 16–19.
- Livingston, E.; Salveson, A. Village of Cloudcroft, New Mexico's PReWater Project, unpublished slide presentation given at the WaterSmart Innovations Conference and Exposition, October 8–10, 2008, in Las Vegas, NV.
- Nix, D. Personal communication, Public Utilities Operations Manager, City of Wichita Falls, TX, 2015.
- Raucher, R.; Tchobanoglous, G. *The Opportunity and Economics of Direct Potable Reuse*. WateReuse Research Foundation: Alexandria, VA, 2014.
- Salveson, A.; Steinle-Darling, E.; Trussell, S.; Trussell, B.; McPherson, L. *Guidelines for Engineered Storage for Direct Potable Reuse*. WateReuse Research Foundation: Alexandria, VA, 2015.
- Stillwell, A. S.; Hoppock, D. C.; Webber, M. E. Energy Recovery from Wastewater Treatment Plants in the United States: A Case Study of the Energy–Water Nexus. *Sustainability.* **2010**, *2*(4), 945–962.
- Taffler, D.; Lesley, D.; Zelenka, A. Hidden Potential—Recycled Water and the Water–Energy–Carbon Nexus. *Water Environ. Technol.* **2008**, *20* (11), 34–41.
- Tchobanoglous, G.; Leverenz, H.; Nellor, M. H.; Crook, J. *Direct Potable Reuse: A Path Forward*. WateReuse Research Foundation: Alexandria, VA, 2011.
- Water Environment Federation (WEF). *Energy Conservation in Water and Wastewater Treatment Facilities*, Manual of Practice 32, WEF Press: Alexandria, VA, 2009.
- UOSA. Upper Occoquan Sewage Authority, web page not dated.
<http://www.uosa.org/IndexUOSA.asp> (accessed 9/3/2015)

Chapter 3

Key Components of a Successful/Sustainable Direct Potable Reuse Program

Fundamental to the implementation of a direct potable reuse (DPR) project is a thorough understanding of the key components necessary for a successful and sustainable DPR program. The key components of a DPR program include: (1) regulatory considerations; (2) technical issues related to the production of safe drinking water; and (3) public outreach. The success of any DPR project will depend on the attention given to each of these key components. In addition, it is necessary to identify and address the technical, operational, and management barriers needed to prevent treatment system failures. The topics considered in this chapter include:

- What are important regulatory considerations?
- What are important technical considerations?
- What are important public outreach considerations?
- What are technical, operational, and management barriers?
- What are the sustainable benefits of DPR?

3.1 Regulatory Component

The relationship of the regulatory component with respect to the technical and outreach components is illustrated in Figure 3.1.

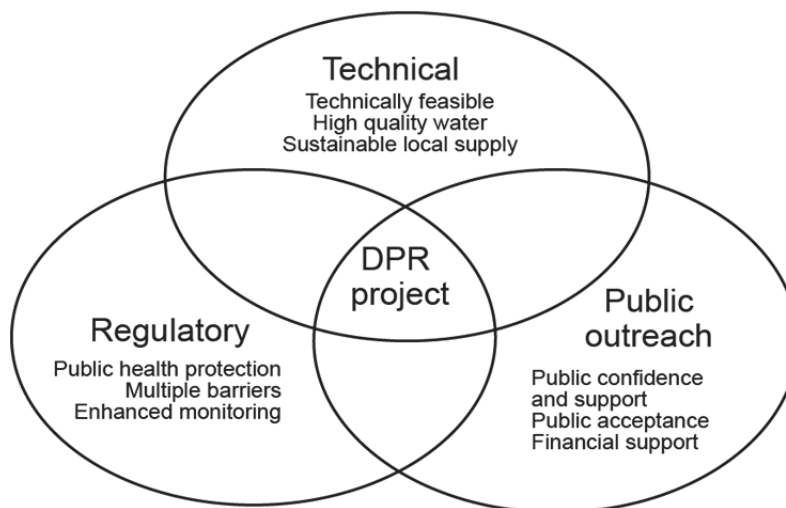

Figure 3.1. Interrelationship of the key components of a DPR program.

Regulations for DPR have not yet been adopted by any state in the United States; however, it was noted in U.S. EPA (2012) that nine states had regulations or guidelines for indirect potable reuse (IPR), including California (CCR, 2015), Florida (FDEP, 2014), Virginia (VDEQ, 2014), and Washington (WSDE, 1997). Currently, Texas is the only state with existing DPR projects, which are evaluated and regulated on a case-by-case basis (see Section 4.5 of Chapter 4 for more information). It is also recognized that de facto potable reuse occurs in many parts of the country. When promulgated, DPR regulations are likely to be similar to IPR regulations; however, additional requirements for DPR may be included on a state-by-state basis, such as added monitoring and operational requirements to account for the lack of an environmental buffer and the need for appropriate response times.

3.1.1 Regulatory Considerations for Direct Potable Reuse

It is the responsibility of regulatory agencies to ensure that public water supply projects comply with applicable federal and state laws, regulations, rules, guidelines, or criteria to produce safe drinking water (see Chapter 4). Because state regulations for DPR do not exist currently, projects may be implemented on a case-by-case basis. Depending on the state where the project is located, proponents of a DPR project will need to work closely with both water and wastewater regulatory agencies.

Implementation can be accomplished in part by requiring a project report (called an engineering report in some states) that contains a complete description of the proposed DPR project. The report should: (1) include the provisions required to address public health issues, such as the control of microbial and chemical constituents; (2) address the advanced water treatment facility (AWTF) specifically [the report may be independent of the engineering report typically required for a drinking water treatment facilities (DWTF)]; and (3) define clearly the means for complying with all requirements specified by the regulatory agency.

For DPR projects designed to introduce advanced treated water (ATW) into the headworks of a DWTF, the report should include (but not be limited to) information on the following:

- Overall description of the design of the proposed AWTF
- Industrial pretreatment and chemical constituent source control program
- Each unit treatment process and its purpose
- Results of any pilot or demonstration plant testing to verify treatment process performance
- Proposed water quality and process monitoring for specific constituents and surrogates, including the type and frequency of monitoring and analytical methodology to be used.
- Ability to meet all regulatory water quality requirements
- Contingency plans to respond to potential water quality excursions
- Ability to detect treatment lapses (should they occur) and time to implement contingency plans, if needed.
- Estimated pathogen (i.e., virus, protozoa, and bacteria) log reductions for each treatment process
- Treatment reliability and the use of multiple treatment barriers
- Ability to provide adequate failure response time (FRT), if needed, to ensure the ATW meets all water quality requirements prior to introduction to the headworks of a DWTF

- Operations and management plan (or the timetable to provide a plan)
- Operator requirements
- Proposed infrastructure (e.g., pipelines and pumping facilities)
- Contingency plans to ensure inadequately treated recycled water will not be used for potable purposes

3.1.2 Other Regulatory Considerations

With DPR, it will be necessary to consider measures to compensate for the lack of an environmental buffer. As discussed in Chapter 2, the main advantage of an environmental buffer includes the ability to provide retention time, dilution, and, in some cases, additional treatment. The disadvantage is the potential to recontaminate the ATW.

The FRT provides the time necessary to identify and correct water quality deficiencies (primarily from constituents presenting acute risks, such as pathogens) that might occur prior to treatment at a DWTF or discharge directly into a drinking water distribution system. The retention time or engineered storage of ATW in DPR projects will be much less than that afforded by environmental buffers in IPR projects for groundwater recharge or surface water augmentation, which will increase the need for (1) robust, multiple treatment barriers and (2) real-time or near real-time monitoring of constituents or surrogates during treatment and in the ATW (Crook, 2010).

Blending (i.e., dilution) may be important in some circumstances (e.g., where ATW mixes with other sources of water prior to treatment at a DWTF) because it may reduce some chemical constituent levels to below regulatory limits and stabilize the water to mitigate aesthetic or operational problems; however, blending can have potential adverse effects, such as decreased water stability and taste or odor problems associated with the increased temperature of the mixture. The potential impacts of blending are discussed in Chapter 8.

3.2 Technical Component

The physical elements that make up the technical component of a DPR system (Tchobanoglous et al., 2011) include the following:

- Source of water supply (e.g., surface water and/or groundwater).
- Source control program for the community or service area where the water will be used, including waste haulers and any tributary wastewater from other jurisdictions.
- Wastewater treatment.
- Advanced water treatment.
- Engineered storage buffer (ESB), if needed.
- Drinking water treatment.
- Associated piping and pumping infrastructure—including the water distribution system, wastewater collection system, and ATW transport system—to the location where it will be introduced into the DWTF or distribution network.

Issues to address for each of these elements are presented in Table 3.1 and discussed in subsequent chapters.

Table 3.1. Some Important Issues for Each of the Elements that Compose the Technical Components of a DPR Program

Element	Issues/Comments
Water supply sources	<ul style="list-style-type: none"> • Develop an operation plan for blending ATW with alternative water sources. • If needed, modify existing system to allow for blending and stabilizing the ATW. • Assess what level of blending, if any, is needed based on quality of ATW and different water sources. • Investigate various blend ratios and rationales for target blend rate range. • Develop an integrated water supply portfolio that includes DPR.
Source control program for community or service area	<ul style="list-style-type: none"> • Modify pretreatment/source control program so it is suitable for DPR. • Identify constituents in wastewater that may be difficult to remove or are precursors to disinfection byproduct formation (depending on treatment technologies used). • Information is needed on sources and concentrations of selected constituents. • Include commercial and industrial entities in source control program. • Develop a program to inform consumers of best practices for home waste disposal.
Wastewater treatment	<ul style="list-style-type: none"> • The better the quality of treated wastewater, the less demand on subsequent advanced treatment processes. • Develop and implement influent monitoring systems. • Determine optimum location, size, and type of flow equalization (inline or offline), and quantify its benefits on performance and reliability of biological and other treatment processes. • Consider how influent monitoring data could be used to adapt treatment operations depending on variable influent characteristics. • Quantify benefits of complete nitrification or nitrification and denitrification on performance of membrane treatment processes used for DPR. • Assess benefits of improvements in biological treatment on removal of both microbial and chemical constituents. • Evaluate optimization of conventional processes (i.e., primary, secondary, and tertiary) to improve overall treatment and reliability of entire system. • Implement a monitoring scheme to ensure treatment performance for each unit process and end-of-process validation of water quality.

Element	Issues/Comments
Advanced water treatment	<ul style="list-style-type: none"> • Determine responsibilities and regulatory authority of wastewater and drinking water agencies operating various treatment facilities to ensure appropriate coordination, training, and response. • Develop influent monitoring systems, including constituents, parameters, and monitoring requirements. • Evaluate alternative treatment schemes with and without demineralization that can be used to treat water. • Define technical and operational requirements for a reliable system. • Develop a monitoring scheme to ensure treatment performance for each unit process and end-of-process validation of water quality. • Select constituents and parameters for monitoring in advanced water treatment processes, including analytical methods, detection limits, and frequency. • Provide standby power systems in the event of power loss or other emergency. • Identify process redundancy so treatment trains can be taken offline for maintenance. • Provide facilities for discharge of off-spec water in the event that water does not meet established quality requirements for influent to DWTF. Example discharge locations include the WWTP, a point in the AWTF, or into the environment.
Engineered storage buffer	<ul style="list-style-type: none"> • Evaluate need for and type of ESB. • Define impact of existing monitoring response times, as well as analytical, detection, and monitoring capabilities, to assess configuration, size, and features of an ESB that may be required.
Drinking water treatment	<ul style="list-style-type: none"> • Mix of source water and ATW should not impact water treatment process or adversely impact finished water quality (see Chapter 8). • Additional treatment, monitoring, and testing may be required.
Engineering infrastructure (piping and pumping)	<ul style="list-style-type: none"> • Investigate potential impacts of ATW on drinking water distribution system (e.g., corrosion issues).

Notes: ATW=advanced treated water; AWTF=advanced water treatment facility; DWTF=drinking water treatment facility; DPR=direct potable reuse; ESB=engineered storage buffer; WWTP=wastewater treatment plant.

Source: Adapted from Tchobanoglous et al. (2011).

3.3 Public Outreach Component

A public outreach program focused on DPR is needed to build public confidence and support of the use of ATW as a source of drinking water supply. The program ideally should launch during the early stages of planning and be maintained throughout the lifetime of the project. Information is available from potable reuse research studies and existing AWTFs to assist in the development of a comprehensive public outreach program for DPR. A list of key activities in developing a public outreach program for DPR is included in Table 3.2 and elaborated upon further in Chapter 12. Strategies to engage both the public and industrial dischargers in source control participation programs are provided in Section 5.5 of Chapter 5.

Table 3.2. Key Activities for Developing a Public Outreach Program for DPR

Outreach Activity	Purpose
Provide a rationale for the need for DPR.	Raise public confidence of the benefits and value of the DPR project to the community.
Identify public perception challenges to the DPR project.	Use to assist in the development of strategies to alleviate these concerns and improve public perception.
Develop a DPR Communication Plan.	Provide strategies to communicate about the DPR project to the public, elected officials, and others, with the goal of building public confidence in and support of the DPR project.
Develop and disseminate communications materials on the DPR project.	Provide objective, accurate, and timely information to raise awareness of the DPR project and address public concerns.
Connect with outreach staff at other AWTFs.	Gain practical information and lessons learned from the real-world experiences of other potable reuse public outreach efforts.
Prepare a participation program for source control.	Engage industrial and commercial dischargers, as well as the public, on means to eliminate or control the discharge of constituents into wastewater that can impact the production of ATW.

Notes: ATW=advanced treated water; AWTF=advanced water treatment facility; DPR=direct potable reuse.

3.4 Technical, Operational, and Management Multiple Barriers

Imbedded within the design of a DPR project is the application of the concept of multiple barriers. As illustrated in Figure 3.2, multiple barriers can be technical, operational, and management barriers. The multiple barrier approach defined by the U.S. Environmental Protection Agency (U.S. EPA) involves risk prevention, risk management, monitoring and compliance, and individual action (U.S. EPA, 2006).

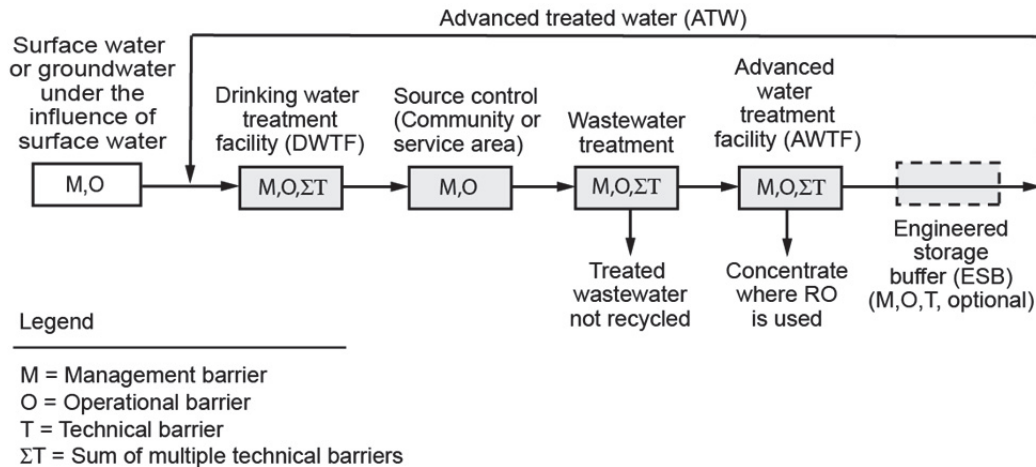

Figure 3.2. Key elements of the multiple-barrier strategy for ensuring water quality in a potable reuse program.

Note: The shaded elements are considered in detail in Chapters 5 through 8.

In practice, multiple barriers are used in series. The objective is to ensure that the failure of a single barrier does not result in the failure of the entire treatment system. The use of multiple independent barriers results in an overall high level of reliability by reducing the risk associated with a single barrier so that overall system resilience is enhanced. Descriptions of the different types of barriers are listed below:

- **Technical barriers**, which also can be viewed as “physical” barriers, are the only barriers that can be credited with treatment performance, though management and operational barriers both can result in improved treatment and water quality. A description of the constituents removed at various levels of treatment is provided in Table 6.1 in Chapter 6.
- **Operational barriers** include operations and monitoring plans, failure and response plans, and operator training and certification. If implemented properly, each results in the reliable production of ATW.
- **Management barriers** are policy and maintenance plans key to the proper functioning and oversight of technical and operational barriers in DPR projects. These can be applied from the source of supply through the production of ATW. They also provide guidance for staff to make critical decisions (e.g., when to shut down the process if water quality data are questionable or treatment performance is compromised).

The bulk of this framework document focuses on technical barriers; however, both operational and management barriers are essential aspects of DPR. As an example, source control is inherently a policy- and procedure-based barrier relying on federal and state source protection regulations, local ordinances, pretreatment permitting procedures, and inspection practices to ensure that problematic waste streams do not enter the sewershed and, therefore, facilitate desired risk reduction and management.

3.5 Direct Benefits/Impacts of Implementing Direct Potable Reuse

The benefits of implementing DPR can be assessed in terms of: (1) public water supply, (2) agriculture, (3) the environment, and (4) sustainability. The discussion of each of these areas of benefit is derived in part from Schroeder et al. (2012).

3.5.1 Public Water Supply Benefits

Urban water supply demands can be met through: (1) the development of local groundwater and surface water reservoirs, rivers, and lakes; (2) development and implementation of interbasin water transfer systems; (3) desalination of brackish water and seawater; (4) conservation; and (5) potable reuse. Compared to other alternatives, DPR can provide a stable, local, supplemental source of water that may be less subject to natural disasters with relatively modest energy requirements (see Chapter 2). Because the water requirements of cities are greater than wastewater discharges, DPR cannot serve as a stand-alone water supply source, but it can be a valuable asset within a broader, integrated, water management portfolio.

3.5.2 Agriculture Benefits

Typically, agriculture uses about 65% of all freshwater withdrawals (excluding power withdrawals) in the United States (Maupin et al., 2014). Water that is not exported for urban use can be made available for food production. Nonpotable reclaimed wastewater is a valuable asset for agricultural application because it also contains nutrients. Water availability is especially significant during drought periods. Given the projected population growth over the next 25 years, protecting agricultural water supplies for irrigation will become of greater importance, especially in times of drought. Because urban and agricultural users often rely on the same water sources, DPR can supplement the amount of water used for potable purposes, which will increase the amount of other waters available for agricultural uses and reduce competition for water between municipalities and agriculture.

3.5.3 Environmental Benefits/Impacts

The use of DPR may reduce the amount of water exported to urban areas or extracted from groundwater, as well as the amount of wastewater discharged to surface waters. In addition, augmented groundwater that is not extracted can help minimize subsidence from the overdrafting of aquifers. Such direct environmental benefits can allow for more effective management of in-stream flows and aquatic ecosystems. For example, reductions in importing water can reduce energy use and its concomitant environmental impacts.

Reducing discharges of wastewater to impaired surface waters in the absence of a total maximum daily load (TMDL) could alleviate water quality impairment and significantly improve water quality in the environment, particularly where wastewater discharges have stringent effluent limits; however, in some cases, reducing discharges to surface waters may adversely affect established ecosystems and decrease the quantity of water available to downstream users. As noted in Section 3.5.2, the reduction of groundwater extractions can help reduce the lowering of groundwater levels and the resulting increase in pumping costs, subsidence, saltwater intrusion, and damage to surface infrastructure. Reducing groundwater overdrafting will also help maintain base flows for many freshwater rivers and streams, thereby protecting aquatic and riparian habitats.

3.5.4 Sustainability

As urban centers continue to grow, especially along coastal and drought-sensitive regions, the stress on existing public water supplies will increase. It is already challenging for many of these communities to develop new local water supplies, and available opportunities are increasingly limited and constrained. At the same time, withdrawing water from inland areas, transporting it to coastal population centers, treating and using it once, and then discharging it to coastal waters is unsustainable. As a consequence, potable reuse is receiving increased attention as a part of the water supply portfolio in many communities, including nonmetropolitan areas facing long-term drought and the depletion of surface water supplies. Vulnerable municipalities, utilities, and agencies must begin to develop the necessary information that will allow potable reuse to become a reality.

3.6 References

- CCR. *Water Recycling Criteria*, Title 22, Division 4, Chapter 3, California Code of Regulations: Sacramento, CA, 2015.
[https://govt.westlaw.com/calregs/Browse/Home/California/CaliforniaCodeofRegulations?guid=IE8ADB4F0D4B911DE8879F88E8B0DAAAE&originationContext=documenttoc&transitionType=Default&contextData=\(sc.Default\)](https://govt.westlaw.com/calregs/Browse/Home/California/CaliforniaCodeofRegulations?guid=IE8ADB4F0D4B911DE8879F88E8B0DAAAE&originationContext=documenttoc&transitionType=Default&contextData=(sc.Default)) (accessed 9/3/2015)
- Crook, J. *Regulatory Aspects of Direct Potable Reuse in California*. National Water Research Institute: Fountain Valley, CA, 2010.
<http://nwri-usa.org/pdfs/NWRIPaperDirectPotableReuse2010.pdf> (accessed 9/3/2015)
- FDEP. *Reuse of Reclaimed Water and Land Application*, Chapter 62-610, Florida Administrative Code, Florida Department of Environmental Protection: Tallahassee, FL, 2014. <https://www.flrules.org/gateway/ChapterHome.asp?Chapter=62-610> (accessed 9/3/2015)
- Maupin, M. A.; Kenny, J. F.; Hutson, S. S.; Lovelace, K. K.; Barber, N. L.; Linsey, K. S. *Estimated Use of Water in the United States in 2010*. U.S. Geological Survey Circular 1405, U.S. Department of the Interior, 1-56, 2014.
<http://pubs.usgs.gov/circ/1405/> (accessed 9/3/2015)
- Schroeder, E.; Tchobanoglous, G.; Leverenz, H. L.; Asano, T. *Direct Potable Reuse: Benefits for Public Water Supplies, Agriculture, the Environment, and Energy Conservation*. National Water Research Institute: Fountain Valley, CA, 2012.
<http://www.nwri-usa.org/documents/NWRIWhitePaperDPRBenefitsJan2012.pdf> (accessed 9/3/2015)
- Tchobanoglous, G.; Leverenz, H.; Nellor, M. H.; Crook, J. *Direct Potable Reuse: A Path Forward*. WateReuse Research Foundation: Alexandria, VA, 2011.
- U.S. EPA. *Hazard Analysis Critical Control Point (HACCP) Strategies for Distribution System Monitoring, Hazard Assessment and Control*. Office of Ground Water and Drinking Water, Standards and Risk Management Division: U.S. Environmental Protection Agency: Washington, DC, 2006.
http://www.epa.gov/ogwdw/disinfection/tcr/pdfs/issuepaper_tcr_haccp-strategies.pdf (accessed 9/3/2015)

- U.S. EPA. *Guidelines for Water Reuse*. EPA/600/R-12/618, Office of Wastewater Management: U.S. Environmental Protection Agency: Washington, DC, 2012.
<http://nepis.epa.gov/Adobe/PDF/P100FS7K.pdf> (accessed 9/3/2015)
- VDEQ. *Water Reclamation and Reuse Regulation (9VAC25-740)*. Virginia Administrative Code, Title 9, Chapter 740, Virginia Department of Environmental Quality: Richmond, VA, 2014.
<http://law.lis.virginia.gov/admincode/title9/agency25/chapter740> (accessed 9/3/2015)
- WSDE. *Water Reclamation and Reuse Standards*. Washington State Department of Ecology: Olympia, WA, 1997.
www.ecy.wa.gov/programs/wq/reclaim/advisorycommittee/standards.pdf (accessed 9/3/2015)

Chapter 4

Public Health and Regulatory Aspects for Direct Potable Reuse

Understanding the human health hazards and exposures associated with chemicals and microorganisms in wastewater is important in the development of potable reuse practices that are protective of public health. Aspects that should be considered include: current knowledge regarding health effects associated with potable reuse, applicable public health concepts, and national regulations that will impact the implementation of direct potable reuse (DPR). The following topics are discussed in this chapter:

- What is public health protection?
- What are the results of health assessments/investigations?
- What are the applicable water quality and treatment regulations?
- What are pathogen log reduction values, and how do they apply to DPR?
- What regulations would be required if advanced treated water (ATW) is classified as a raw water source?

4.1 Public Health Protection

Public health protection requires that microbiological and chemical constituents in wastewater be removed to the extent practical before discharge to the environment or for other uses. Complete removal of all microorganisms and chemicals is impossible; therefore, goals are established to limit human exposure of specific identified agents to concentrations that are not harmful to human health. The maximum allowable concentrations of these agents are established as standards. In the United States, these standards for drinking water are known as maximum contaminant levels (MCLs) for chemicals and log reductions for pathogens and fecal indicator bacteria.

4.2 Overview of Health Effects Assessments

To understand the development of existing drinking water regulations and the application of these regulations to potable reuse, it is useful to:

- Consider how health effects are assessed.
- Review health effects that were considered in National Research Council (NRC) studies on potable reuse.
- Review what epidemiological, risk assessment, and toxicological health effects studies have been conducted for potable reuse.

4.2.1 Assessment of Human Health Effects

Human health effects assessments can be based on studies using (1) test animals or (2) biochemical or cellular systems. Examples include epidemiological, microbiological, and toxicological studies. Brief descriptions of these studies, as well as a summary of their limitations, are provided in Sections 4.2.1.1 to 4.2.1.4. Additional information can be found in Asano et al. (2007), Cotruvo (1987), Haas et al. (2014), ILSI (2000), and NRC (2012).

4.2.1.1 Epidemiological Studies

Epidemiological studies focus on measurable changes in the incidence or processes of disease in human populations that are observed in an exposed population as compared to populations lacking or experiencing less exposure. Examples include ecological epidemiology studies (which compare aggregated data from different populations) and analytical epidemiology studies (which require more detailed controls or information from exposed and control populations). In general, it is difficult to detect low incremental risks or differentiate them from background disease occurrence with epidemiology studies. Because exposures to chemicals from food, water, and the environment are difficult to define, care must be taken to identify and quantify the exposure as accurately as possible and control for variables (e.g., ethnic distribution, genetics, and economics) that may confound the outcome or result in exposure misclassifications.

4.2.1.2 Microbiological Studies

Microbiological studies, which assess the infectivity of pathogens that cause human disease, are conducted with a known exposure to measure indications of harmful effects through time following exposure. These controlled dose-response infectivity studies are used to estimate risks of infection at various exposure levels encountered from water. Additional details may be found in ILSI (2000) and Haas et al. (2014).

4.2.1.3 Toxicological Studies

Toxicological studies in experimental animals are conducted for varying lengths of time and with multiple dose levels to obtain a dose-response relationship. Because the dose levels used tend to be much greater than human exposures from drinking water, the dose-response relationship must be extrapolated to low doses. The process of using animal data for human safety assessments goes through two stages: first, likely adverse health outcomes are identified, followed by an estimate of dose-response relationships that can be extrapolated to humans. It should be understood that “safe” does not indicate zero risk, but rather acceptable risks that are unlikely to occur at doses represented by MCLs.

4.2.1.4 Limitations of Epidemiological, Microbiological, and Toxicological Studies

Neither epidemiological nor toxicological studies are sensitive to the low levels of exposure usually allowed in drinking water. Microbiological risks have been developed based on disease outbreaks in public water supplies that can be attributed to a specific organism. Conversely, the contribution of a chemical constituent to a specific adverse health outcome must be differentiated from other causes of that outcome, which is more difficult. With a single epidemiological study, care should be exercised in accepting either positive or negative results. The results must be confirmed independently with replication on other study

populations. Multiple studies are required frequently before an association or lack thereof can be accepted as fact.

Some animal studies have been conducted using concentrated samples of organic chemicals in water. When evaluating individual chemicals, these studies are conducted at very high doses with the assumption that the effects observed can be extrapolated to environmental exposures at doses that are orders of magnitude lower; therefore, risks associated with these individual chemicals give rise to conservative public health guidelines.

4.2.2 National Research Council Studies on Potable Reuse

Two NRC studies have been conducted within the past 20 years (NRC, 1998, 2012) in which potential challenges were identified and appropriate solutions were suggested for ensuring that potable reuse was a safe practice from a public health perspective. The findings from these studies with respect to chemical and microbial constituents are described in Sections 4.2.2.1 and 4.2.2.2.

4.2.2.1 Risk from Chemical Constituents

Water quality is assured by source control programs, treatment technologies that meet drinking water MCLs and other limits, and monitoring for constituents that present a health risk. For advanced treatment trains, most chemicals are not detected; those that are detected are found at levels lower than those found in conventionally treated drinking water supplies (NRC, 2012).

4.2.2.2 Risk from Pathogens

In the 2012 NRC report, it was concluded that the risk from pathogens in potable reuse “does not appear to be any higher, and may be orders of magnitude lower, than currently experienced in at least some current (and approved) drinking water treatment systems (i.e., *de facto* reuse).”

4.2.3 Epidemiological, Risk Assessment, and Toxicological Health Effects Studies on Potable Reuse

Several epidemiological and toxicological health effects studies have been conducted in the last 30 years to evaluate the public health implications of potable reuse. These studies were summarized in the 1998 NRC report on potable reuse. Health effects data from some existing and demonstration potable reuse facilities, including the first DPR project (Windhoek, Namibia), are summarized in Appendix A.¹ The limited sensitivity and nature of the toxicological and epidemiological techniques (see Section 4.2.1.4) hinder the usefulness of study results for evaluating potable reuse projects in general. The results have been negative for both epidemiological studies of groundwater recharge (e.g., the Montebello Forebay) and whole animal studies of recycled water intended for potable reuse in several locations (e.g.,

¹ An epidemiological study was conducted from 1976 to 1983 that looked at cases of diarrheal disease. In 1998, the National Research Council Committee concluded that, because of limitations in the Windhoek epidemiological studies and Windhoek’s “unique environment and demographics, these results cannot be extrapolated to other populations in industrialized countries” (NRC, 1998).

Denver, Tampa, and Singapore). Although these studies had deficiencies, the fact that the results were all negative provides some assurance that the risks are very low.

Further, a blue-ribbon panel formed by the California State Water Resources Control Board (SWRCB) reviewed the results of many key studies conducted over the past 40 years on the toxicological relevance to humans of constituents of emerging concern (CECs) in recycled water (see Section 4.5.1.3 and Anderson et al., 2010). On the basis of this review, the panel noted:

“In summary, the Panel views the predominantly negative findings of the combined epidemiological studies, laboratory rodent studies, bio-analytical screening studies and risk assessments as several concordant lines of evidence that appropriately treated recycled water represents a safe source of water to supplement potable drinking water supplies. The predominantly negative findings described above do not preclude the need to monitor recycled water to assure its continued safety.”

Finally, several representative quantitative relative risk assessment (QRR) studies have been conducted evaluating the risks to human health associated with the use of recycled water for groundwater replenishment, as well as for potable reuse (see Appendix B).

4.3 Clean Water Act

The 1972 Clean Water Act (CWA) is the federal law that established the basic structure for regulating pollutant discharges into the waters of the United States. Under the CWA, the U.S. EPA was given authority to implement pollution control programs, such as setting wastewater standards for industry; existing requirements from the Federal Water Pollution Control Act of 1948 were maintained to set water quality standards for contaminants in surface waters; and the discharge of any pollutant from a point source into navigable waters became illegal, unless a permit was obtained under its provisions.

The implementation of the CWA has resulted in significant improvements in the quality of wastewater discharges and, in turn, has improved the quality of ambient water sources. As a result, water recycling, including potable water reuse, has become more attainable (Cotruvo, 2014). Secondary wastewater treatment—and often filtered and disinfected secondary treatment—is now almost universally applied in the United States. Individual states are obligated to develop standards for designated uses for waters of the United States using water quality criteria that have been proven by the U.S. EPA to protect those uses.

Discharges to surface waters from industries or publicly owned treatment works (POTWs) are controlled by National Pollutant Discharge Elimination System (NPDES) permits. The National Pretreatment Program (discussed in Chapter 5) was created as part of the CWA to address the discharge of toxics from nondomestic sources to POTWs. Pretreatment requirements have been established for chemical discharges to municipal wastewater systems. Ambient water quality criteria have been established to classify water quality specifications according to designated use (which can include municipal drinking water supply). Combined, this legislation has resulted in higher quality treated wastewater and a better understanding of what constituents remain in treated effluents.

4.4 Applicable Regulations

Water distributed to communities for potable use is subject to drinking water quality requirements derived from the Safe Drinking Water Act (SDWA), regardless of the initial source of the influent water. Federal regulations such as the SDWA are considered in Sections 4.4.1 and 4.4.2.

4.4.1 Safe Drinking Water Act

The SDWA is the federal law that establishes the minimum quality standards for drinking water in the United States (U.S. EPA, 2015a). Passed by Congress in 1974, the SDWA replaced existing Public Health Service standards to provide both a new overarching regulatory framework and to empower the U.S. EPA with oversight of the law's implementation. Amended in 1986 and 1996, the law also requires a number of actions to protect drinking water and its sources: rivers, lakes, reservoirs, springs, and groundwater. The 1996 amendments enhanced the existing law by recognizing source water protection, operator training, funding for water system improvements, and public information as important components of safe drinking water. This approach ensures the quality of drinking water by protecting it from source to tap. It is important to note that the decision to regulate under the SDWA involves careful analysis to weigh the public health benefits of requiring control of a contaminant with the costs associated with imposing such controls.

Under the SDWA, the U.S. EPA sets national health-based standards for drinking water to protect against both naturally occurring and manmade constituents that may be found in drinking water. Subsequent implementation, with the exception of Wyoming, District of Columbia, U.S. territories, and some Indian Lands, is through state primacy agency oversight of public water systems that implement these standards. State drinking water regulations must be at least as stringent as national primary standards.

4.4.2 National Drinking Water Regulations

The SDWA regulations include primary and secondary drinking water standards. Primary standards, known as MCLs, are established for contaminants that may pose a health risk when present in drinking water supplies and are known or anticipated to occur in public water systems. As enforceable maximum permissible levels of regulated constituents in drinking water, MCLs are set at concentrations that are as close as possible to levels that are not anticipated to have public health consequences, with a margin of safety (known as Maximum Contaminant Level Goals (MCLGs)).

In setting MCLs, the U.S. EPA takes into account the availability of treatment options, suitable analytical methods, and the costs of control measures. Treatment requirements are established for constituents for which control is important to public health, but monitoring is not technically and economically feasible, to set MCLs. Both MCLs and treatment technique requirements include minimum monitoring requirements that reflect the nature of the health risk and effectiveness of the control measures.

Secondary standards, known as Secondary Maximum Contaminant Levels (SMCLs), are established for constituents that have aesthetic effects. SMCLs are not enforceable under federal law, but some states have incorporated them into their enforceable standards (U.S. EPA, 2013).

4.4.2.1 Total Organic Carbon Removal—An Example Treatment Technique

The Disinfectants and Disinfectant Byproducts Rule (40 CFR, December 16, 1998) requires that public water supplies using surface water or groundwater under the influence of surface water (GWUDI) remove a certain percentage of the total organic carbon (TOC) in the source water based upon its alkalinity. The intent of this requirement is to reduce disinfection byproduct (DBP) formation by limiting precursors prior to disinfection, using TOC as the surrogate. Application to a DPR project would require some interpretation and selection of the defined source water, such as secondary or tertiary treated wastewater.

4.4.2.2 Filter Backwash Recycling Rule

In Section 1412(b)(14) of the SDWA, the U.S. EPA is required to provide filter backwash water recycling requirements applicable to surface water and GWUDI sources with direct or conventional filtration. These requirements may include recycle backwash, sludge thickener supernatant, or dewatering liquids. Because return flows are assumed to have increased levels of pathogens, the Filter Backwash Recycling Rule is intended to control microbials in finished water by recycling return flows through the complete treatment process.

4.4.2.3 Managing Risk from Source to Tap

The concept of multiple barriers has been a design consideration in drinking water treatment facilities (DWTs) for more than half a century. It now formally includes the protection of water supply sources. In the 1996 SDWA amendments, provisions were included to require a deliberate assessment of water supply sources for hazards so that additional risk mitigation measures could be taken.

Currently, Source Water Protection Programs (SWPPs) include the following tasks: (1) risk identification (delineation and source inventories); (2) risk ranking and screening (susceptibility analyses); (3) risk management measures (prevention programs); and (4) preparation for unexpected drinking water supply replacement emergencies (contingency planning) (U.S. EPA, 1997). The four fundamental elements of SWPPs are listed in Table 4.1.

The success of the SWPP is assessed by conducting sanitary surveys on a routine basis to prevent the contamination of drinking water supplies (i.e., both source water and finished drinking water). Furthermore, sanitary surveys provide an opportunity to work and communicate with water systems in a preventative mode. The U.S. EPA has defined a sanitary survey as:

“Onsite review of the water source, facilities, equipment, operation and maintenance of a public water system for the purpose of evaluating the adequacy of such source, facilities, equipment, operation, and maintenance for producing and distributing safe drinking water.” (40 CFR 141.2; U.S. EPA, 2003)

The seamless integration of SWPP principles and the elements of a POTW source control program, as discussed in Chapter 5, will be necessary for a successful DPR program.

Table 4.1. Fundamental Elements of Source Water Protection Programs

Barrier	Description
Risk prevention	The best approach to protect drinking water is to keep constituents from entering source water.
Risk management	The public water system is the first line of defense to reduce or eliminate constituents in source water. The SDWA, which regulates these systems, develops standards and guidance to help public water systems reach the goal of providing safe and reliable drinking water. Public water systems must collect and treat water, hire trained and qualified operators, and have an emergency response plan in case of a natural disaster or terrorist attack.
Risk monitoring and compliance	Dealing effectively with risks to drinking water requires constant evaluation of water quality. Water is monitored in one or more locations: (1) source; (2) treatment plant, after it has been treated and disinfected; (3) distribution system, which delivers water through pumps and pipes to homes; and (4) in some cases, consumer's tap, though it is not regulated at all of these locations.
Individual action	What occurs in the watershed can impact directly the quality of water that arrives at the treatment plant. The more the public knows about their drinking water, the better equipped they are to protect it.

Note: SDWA=Safe Drinking Water Act.

Source: U.S. EPA (1997).

4.4.3 Selecting Constituents for Targeted Risk Management

In 2008, the U.S. EPA conducted an extensive search of available data sources and found information on approximately 26,000 chemicals with some potential of occurring in drinking water (73 FR 9628). From this list of chemicals, the U.S. EPA selected a contaminant candidate list (CCL) of roughly 100 chemicals and microbials to investigate further. The CCL includes constituents that the U.S. EPA believes:

- Are not regulated currently under the SDWA.
- May cause adverse health effects.
- Have been detected or are anticipated to occur in public water systems.
- May require regulation under the SDWA.

Every 5 years, the U.S. EPA updates the CCL as a requirement of the SDWA. The most recent update (CCL3) was published in 2009 and contains 116 chemical and microbial constituents, including steroid hormones and one antibiotic. Currently under consideration, CCL4 is being reviewed by stakeholders with respect to the number of constituents that should be evaluated for toxicity and occurrence.

4.4.3.1 Chemical Constituents of Concern

Numerous potential chemical constituents in DPR sources (SWRCB, 2010; NWRI, 2013; see also Appendix C) may have adverse effects on health if they survive typical treatment processes and are found in finished drinking water at sufficient concentrations. Advanced

water treatment technologies capable of producing ATW that meets all drinking water standards have been demonstrated in numerous investigations and full-scale AWTs. In general, the ATW is of higher quality than most conventionally treated drinking waters with respect to total organic carbon (TOC) and total dissolved solids (TDS), as well as trace constituents.

The microbial, chemical, and treatment standards for providing public drinking water and assessing raw water supplies developed under the SDWA provide a comprehensive basis for evaluating both the (1) acceptability of finished drinking water and (2) protection of water supply sources. Typical drinking water treatment processes are effective at limiting the levels of these chemical constituents in finished drinking water; therefore, a large number of new MCLs applicable specifically to DPR systems do not need to be developed. The best management approach would be to ensure that appropriate multiple-barrier technologies—conceptually similar to the SDWA multiple-barrier risk reduction approach—are installed and operating to specification (i.e., an optimized and reliable treatment system) and key constituents are identified to verify the performance of the technologies.

Numerous sources of health-based benchmarks exist for chemicals in addition to the drinking water standards that can be used if unregulated constituents are detected. Some of these sources include the World Health Organization’s *Guidelines for Drinking Water Quality* (WHO, 2011), several hundred Drinking Water Health Advisories (U.S. EPA, 2012, 2015b), more than 350 Pesticides Human Health Benchmarks (U.S. EPA, 2015c), and the 2009 Australian Guidelines for Water Recycling (NRMCC et al., 2009). “Margins of Exposure” and “Thresholds of Toxicological Concern,” as well as detailed risk assessments, are techniques available to produce health-based benchmark values.

4.4.3.2 Microbial Constituents of Concern

For microbial constituents of concern (COCs), the original Surface Water Treatment Rule (FR 54, 124, June 29, 1989) required, in part, that DWTs using surface water and GWUDI sources must filter and disinfect the water and achieve 4-log reduction of virus² and 3-log reduction of *Giardia* spp.

More recently, the Long Term 2 Enhanced Surface Water Treatment Rule (LT2ESWTR) (71 FR 654, January 5, 2006) dealt primarily with ensuring the control of *Cryptosporidium*,³ as well as other microbial constituents. Although the LT2ESWTR did not change the long-standing informal public health risk goal of 1/10,000 infections per year, it was the first drinking water standard to tailor a minimum required treatment at individual DWTs. It should be noted that the 1/10,000 goal is similar to the World Health Organization’s drinking water guideline recommendation of 1/1,000,000 disability adjusted life years (DALY) for microbial disease risk. Specifically, for surface waters and GWUDI sources, public health

² A risk-based evaluation was used to assess meeting the public health risk goal of less than 1 illness per 10,000 people per year. The analysis relied on a combination of characteristics (e.g., a rotavirus dose–response function and enterovirus occurrence data [Regli et al., 1991]). Note that quantitative microbial risk assessments (QMRAs) are based on the assumption that the severity of the endpoint (i.e., infection or disease) is not influenced by the dose. This assumption is not appropriate for all pathogens at all doses, and it is not used in QMRAs at present.

³ *Cryptosporidium* is among the most difficult microorganisms to treat in water because of its small size (~3 to 6 µm) and resistance to chlorination.

protection is to be achieved through installing sufficient treatment⁴ technologies to achieve log reductions⁵ of *Cryptosporidium* ranging from 2 log (multiple disinfection with source <0.01 oocyst/liter) to 3 log (conventional surface drinking water filtration and disinfection treatment) to 5.5 log, depending on the concentrations of *Cryptosporidium* measured in 24 monthly source water samplings.

At present (and at a minimum), a DPR framework for microbial contaminants will need to provide a water quality entering the DWTF sufficient to allow the public water systems to comply with the treatment expectations of the SWTR, Interim Enhanced Surface Water Treatment Rule, and LT2ESWTR. Various advanced water treatment process trains are discussed in Chapter 7 with this goal in mind.

4.5 Criteria for Direct Potable Reuse

Currently, federal regulations do not exist specifically for DPR, and no state has yet to develop specific regulations for DPR.

California has existing regulations for indirect potable reuse (IPR) via groundwater recharge and is in the process of developing criteria via surface water augmentation. The California Water Code (CWC) requires California to adopt IPR regulations for surface water augmentation by the end of 2016. Furthermore, the CWC requires that the Department of Drinking Water (DDW) of the California State Water Resources Control Board (SWRCB) investigate the feasibility of developing criteria for DPR and provide a final report on that investigation to the legislature by the end of 2016.

Texas, which is the only state that currently has existing DPR projects, approves such projects on a case-by-case basis. The Texas Commission on Environmental Quality has developed permit requirements for two specific DPR projects (e.g., the Colorado River Municipal Water District project at Big Spring, TX, and the DPR project for Wichita Falls, TX, which is an emergency water supply).

Additional discussions of applicable regulations that can be applied to DPR are provided in Sections 4.5.1 to 4.5.3.

4.5.1 California Indirect Potable Reuse Regulations

California has adopted regulations for groundwater recharge IPR projects that address both pathogens and chemical constituents. Although the California regulations apply to groundwater recharge IPR projects where groundwater is not influenced by surface waters, the regulations are relevant; they serve as a useful starting point for the development of regulations for DPR projects. For pathogens, DDW requires IPR treatment to achieve at least 12-log reduction of enteric virus, 10-log reduction of *Giardia* cysts, and 10-log reduction of

⁴ The LT2ESWTR assigns log-reduction credits to a variety of technologies, and states can assign credits for other technologies based upon performance data (e.g., membrane credits are based upon challenge testing). Log credits for disinfectants are based upon CT values (i.e., residual disinfectant concentration, C, mg/L multiplied by the contact time, T, minutes).

⁵ Water supplies that can demonstrate low risk of *Cryptosporidium* contamination and wish to avoid filtration can meet requirements by using two disinfectants that can control *Cryptosporidium*, such as ozone, ultraviolet (UV) disinfection, or chlorine dioxide.

Cryptosporidium oocysts from raw wastewater. Log reduction credits may be applied to all treatment processes provided. The regulations also include limits for chemical constituents (e.g., MCLs), notification levels (NLs), and other constituents specified by DDW. Monitoring and removal requirements for constituents of emerging concern (CECs) are also specified. It is expected that monitoring for pathogens or indicators and CECs in DPR systems will be at least as stringent as that required for IPR.

4.5.1.1 Constituents of Emerging Concern

CECs and their byproducts represent a challenge for regulators to address owing to limited scientific knowledge about their fate and health effects. An Independent Advisory Panel (IAP) convened by the National Water Research Institute (NWRI) developed a list of recommended CECs to be considered for performance monitoring in DPR projects (see Appendix C, which is based on the 2013 NWRI IAP report as an example of recommended CECs for monitoring).

4.5.1.2 Guidance Documents

The SWRCB issued a Recycled Water Policy in 2009 (updated in 2013) (SWRCB, 2014) that, among other efforts, sought to incorporate the most current scientific knowledge on CECs into regulatory policies for use by state agencies. A blue-ribbon panel was formed to address the following questions:

- What are the appropriate constituents to be monitored in recycled water, and what are the applicable monitoring methods and detection limits?
- What toxicological information is available for these constituents?
- Would the constituent list change based on the level of treatment? If so, how?
- What are the possible indicators (i.e., surrogates) that represent a suite of CECs?
- What levels of CEC should trigger enhanced monitoring in recycled water, groundwater, or surface water?

The blue-ribbon panel produced several products to guide the state's recycled water management approaches. First, the panel developed a risk-based framework for prioritizing and selecting CECs for recycled water monitoring programs (Anderson et al., 2010). The framework was then used to develop a short list of recommended monitoring parameters, including both health- (i.e., toxicologically relevant CECs) and performance-based indicators (i.e., CECs with representative physicochemical properties and structures tested to demonstrate a capacity for the reduction by a particular water treatment process). The list also incorporates CECs from multiple source classes (e.g., pharmaceuticals, personal care products, food additives, and hormones). Four health-based and five performance-based indicators were identified for recycled water used for groundwater recharge, whereas only three surrogate parameters (i.e., turbidity, chlorine residual, and total coliform bacteria) were recommended for monitoring water used for landscape irrigation.

In addition, the panel developed guidance for interpreting and responding to monitoring results. The SWRCB considered the panel's report and public comments before adopting an amendment to the Recycled Water Policy to establish monitoring requirements for CECs in recycled water (Drewes et al., 2013; SWRCB, 2013). The list has received feedback on the recommended treatment for caffeine and Triclosan, which were based on Australian drinking

water guidelines considered exceptionally conservative by the panel. For instance, the derivation for caffeine did not reflect current toxicological principles. NWRI (2013) included a much higher and less conservative specific limit for Triclosan based on an analysis contained in the 2012 NRC report; it considered both Triclosan and caffeine as appropriate only as treatment performance surrogates.

4.5.2 National Water Research Institute Panel Recommendations

In 2013, an IAP convened by NWRI evaluated microbial and chemical criteria for DPR from raw wastewater (NWRI, 2013). The findings are presented in Sections 4.5.3.1 and 4.5.3.2.

4.5.2.1 Microbial Criteria

Criteria suggested by the NWRI IAP for the microbial evaluation of AWWTF treatment trains for the protection of public health are provided in Table 4.2.

Table 4.2. Microbial Reduction Criteria for AWWTF Treatment Trains^a

Microbial Group	Criterion (Minimum Log Reduction)	Possible Surrogates
Enteric virus	12	MS2 bacteriophage
<i>Cryptosporidium</i> spp. ^b	10	Latex microspheres, AC fine dust, inactivated <i>Cryptosporidium</i> oocysts, aerobic spores
Total coliform bacteria ^c	9	Not applicable

Notes: ^aReduction criteria for AWWTF, including secondary treatment; ^bAddresses *Giardia* and other protozoa as well; ^cAddresses enteric pathogenic bacteria, such as *Salmonella* spp.

Source: Adapted from NWRI (2013).

The NWRI IAP concluded that all three criteria were conservative and achieved risks less than the 1/10,000 target goal. It selected a 12-log reduction criterion for enteric viruses based on several conservative factors:

- Use of maximum versus average concentrations in raw wastewater.
- Use of infectivity data from one of the most infectious viruses, which may not be the most commonly occurring.
- Assumption that all infections would cause disease.

Log reduction criteria for *Giardia* are not included in Table 4.2 because the IAP concluded that the 10-log reduction of *Cryptosporidium* oocysts will ensure the same or greater reduction of *Giardia* cysts, as *Giardia* cysts are both larger and more easily disinfected.

The NWRI IAP also selected total coliform bacteria for the operating criterion because total coliform bacteria are present in wastewater at concentrations much greater than enteric bacterial pathogens and *E. coli* and are easily monitored and accepted among the several bacterial surrogates for measuring the effectiveness of disinfection. The NWRI IAP concluded that a 9-log reduction of total coliform bacteria in the combined wastewater and drinking water treatment processes would also provide a de minimis annual risk of infection from *Salmonella* spp. and other enteric bacterial pathogens, which assumes that the coliforms and pathogens are inactivated or removed with similar effectiveness by treatment processes. More detail on the rationale used to select the microbial groups and their respective minimum log reduction criteria, as seen in Table 4.2, is available in NWRI (2013).

4.5.2.2 Chemical Criteria

Trace chemicals of interest in raw and treated water were addressed with respect to monitoring and benchmarks. The NWRI IAP suggested analytical tools that could be used to ascertain treatment efficiencies for alternative treatment trains and develop a framework for determining the criteria to protect public health, rather than demonstrate regulatory compliance. Decisions ultimately need to be made as to which of the listed chemicals should be included in testing, based upon their likely presence and significance, and the appropriate locations in the treatment train (NWRI, 2013).

Selecting chemicals as benchmarks for evaluating the efficacy of treatment trains within an AWWTF should focus upon certain key factors, including the following:

- Treatment trains capable of producing water that meets published guidelines or health advisory levels
- Constituents/parameters used for establishing performance occurring within the source water at a high frequency and at sufficient concentrations to allow for a large dynamic range for evaluating treatment trains
- Availability of appropriately sensitive and specific analytical methods
- A diversity of constituents that are broadly representative of the various types of constituents of health concern that could be present in wastewater
- An array of constituents with different properties that affect their removal by various unit processes within a treatment train
- Real-time online monitoring potential

Three classes of chemicals were identified: (1) chemicals of potential interest from the standpoint of public health if present in wastewater (e.g., 1,4-dioxane); (2) steroid hormones (e.g., 17 β -estradiol); and (3) chemicals useful for evaluating the effectiveness of organic chemical removal by treatment trains (e.g., pharmaceuticals). Both bromide and bromate also are recommended for analysis because bromide is a precursor to bromate, which represents a byproduct of concern formed during the ozonation and chlorination of recycled water (NWRI, 2013).

4.5.3 Texas Regulations

Although Texas does not have specific statewide regulations for DPR and permits such projects on a case-by-case basis, the Texas Commission on Environmental Quality (TCEQ) has taken an approach similar to California regarding pathogens (APAI, 2015).

For example, for the Wichita Falls DPR project (see Table 2.1), TCEQ requires 9-log reduction of viruses, 8-log reduction of *Giardia* cysts, and 5.5-log reduction of *Cryptosporidium* oocysts based on an assessment of the quality of the secondary effluent and pertinent regulations. Chemical constituent limits are somewhat similar to those imposed by California for IPR projects and other limits and monitoring suggested in NWRI (2013).

The difference between the Texas and California log reduction values is based on the processes included in the allocation of log reduction values (see Chapter 7).

4.6 Advanced Treated Water as a Raw Potable Water Source

The SDWA framework was constructed during the 1970s, 1980s, and 1990s, when source waters were untreated water from streams, rivers, lakes, and groundwater aquifers. With competing demands for these natural water sources (e.g., in-stream flow, agricultural use, and concentrated population growth in arid portions of the United States), consideration must now be given to ATW as a source of drinking water supply. In addition, research and practical experience have been gained in the removal of pollutants and naturally occurring constituents. The efficacy and cost efficiency of wastewater and drinking water treatment technologies considered routinely in facility design today have changed substantially from those in use when the SDWA was first drafted (Cotruvo, 2014). Also, technologies like advanced oxidation were, at best, research concepts even as the SDWA was reauthorized for its second and third time.

At present, a sound technical basis exists for developing recycling programs that incorporate IPR and DPR that are protective of public health. By building on key elements of the existing SDWA and CWA frameworks, the water industry can move forward to incorporate ATW as a source of raw drinking water supply. Providing a cohesive framework for DPR is prudent to ensure adequate safeguards and consistency with existing regulatory constructs, but also to provide assurance to communities moving forward with potable reuse projects.

4.7 References

- APAI. *Final Report: Direct Potable Reuse Resource Document*. Report prepared for the Texas Water Development Board by Alan Plummer Associates, Inc.: Fort Worth, TX, 2015.
http://www.twdb.texas.gov/publications/reports/contracted_reports/doc/1248321508_Vol1.pdf (accessed 9/3/2015)
http://www.twdb.texas.gov/publications/reports/contracted_reports/doc/1248321508_Vol2.pdf (accessed 9/3/2015)
- Asano, T.; Burton, F. L.; Leverenz, H.; Tsuchihashi, R.; Tchobanoglous, G. *Water Reuse: Issues, Technologies, and Applications*. McGraw-Hill: New York, 2007.
- Cotruvo, J. A. Risk Assessment and Control Decisions for Protecting Drinking Water Quality. In Suffet, I. A.; Malayiandi, M., eds., *Organic Pollutants in Water, Advances in Chemistry Series*, No. 214. American Chemical Society: Washington, DC, 1987.
- Cotruvo, J. A. Direct Potable Reuse: Then and Now. *World Water: Reuse Desal.* 2014, 5 (1), 10–13.

- Drewes, J. E.; Anderson, P.; Denslow, N.; Olivieri, A.; Schlenk, D.; Snyder, S. A.; Maruya, K. A. Designing Monitoring Programs for Chemicals of Emerging Concern in Potable Reuse—What to Include and What Not to Include? *Water Sci. Technol.* **2013**, *67* (2), 433–439.
- Haas, C. N.; Rose, J. B.; Gerba, C. P. *Quantitative Microbial Risk Assessment*, 2nd ed. John Wiley & Sons: New York, 2014.
- ILSI. *Revised Framework for Microbial Risk Assessment*. Risk Science Institute Pathogen Risk Assessment Working Group, International Life Sciences Institute Press: Washington, DC, 2000.
- NRC. *Issues in Potable Reuse: The Viability of Augmenting Drinking Water Supplies With Reclaimed Water*. National Research Council, National Academies Press: Washington, DC, 1998.
- NRC. *Water Reuse: Potential for Expanding the Nation's Water Supply through Reuse of Municipal Wastewater*. National Research Council, National Academies Press: Washington, DC, 2012.
http://www.nap.edu/catalog.php?record_id=13303 (accessed 9/3/2015)
- NWRI. *Examining the Criteria for Direct Potable Reuse*. Independent Advisory Panel Final Report prepared by Trussell Technologies, Inc., under WateReuse Research Foundation Project No. 11-02, National Water Research Institute: Fountain Valley, CA, 2013.
<https://www.watereuse.org/product/11-02-1> (accessed 9/3/2015)
- NRMCM, EPHC, and NHMRC. *National Water Quality Management Strategy Australian Guidelines for Water Recycling: Managing Health and Environmental Risks (Phase 2): Managed Aquifer Recharge*. Natural Resource Management Ministerial Council, Environment Protection and Heritage Council, and National Health and Medical Research Council, Canberra, Australia: 2009.
<http://www.environment.gov.au/water/quality/publications/nwqms-australian-guidelines-water-recycling-managing-health-phase2-aquifer-recharge> (accessed 9/3/2015)
- Nellor, M. H.; Baird, R. B.; Smyth, J. *Health Effects Study Final Report*. County Sanitation Districts of Los Angeles County: Whittier, CA, 1984.
- Regli, S.; Rose, J. B.; Haas, C. N.; Gerba, C. P. Modeling the Risk from Giardia and Viruses in Drinking Water. *J. AWWA* **1991**, *83* (11), 76–84.
- SWRCB. *Final Report: Monitoring Strategies for Chemicals of Emerging Concern (CECs) in Recycled Water—Recommendations of a Science Advisory Panel*. California State Water Resources Control Board: Sacramento, CA, 2010.
http://www.waterboards.ca.gov/water_issues/programs/water_recycling_policy/docs/cec_monitoring_rpt.pdf (accessed 9/3/2015)
- SWRCB. California State Water Resources Control Board Resolution 2013-0003, 2013.
http://www.waterboards.ca.gov/board_decisions/adopted_orders/resolutions/2013/rs2013_0003_a.pdf (accessed 9/3/2015)

- SWRCB. Recycled Water Policy, webpage last updated by the California State Water Resources Control Board on October 1, 2014.
http://www.waterboards.ca.gov/water_issues/programs/water_recycling_policy/index.shtml (accessed 9/3/2015)
- U.S. EPA. *State Source Water Assessment and Protection Programs: Final Guidance*. EPA 816-R-97-009, Office of Water, U.S. Environmental Protection Agency: Washington, DC, 1997.
<http://www.epa.gov/safewater/sourcewater/pubs/swpguidance.pdf> (accessed 9/3/2015)
- U.S. EPA. *Drinking Water Inspector's Field Reference for Use When Conducting a Sanitary Survey of a Small Surface Water System*. EPA 816-R-03-022, Office of Water, U.S. Environmental Protection Agency: Washington, DC, 2003.
http://www.epa.gov/ogwdw/dwa/sanitarysurvey/pdfs/training_sanitarysurvey_fieldguide_sourcewater.pdf (accessed 9/3/2015)
- U.S. EPA. *2012 Edition of Drinking Water Standards and Health Advisories*, EPA 822-S-12-001. Office of Water, U.S. Environmental Protection Agency: Washington, DC, 2012.
<http://water.epa.gov/action/advisories/drinking/upload/dwstandards2012.pdf> (accessed 9/3/2015)
- U.S. EPA. Secondary Drinking Water Regulations: Guidance for Nuisance Chemicals, webpage last updated by the U.S. Environmental Protection Agency on May 31, 2013.
<http://water.epa.gov/drink/contaminants/secondarystandards.cfm> (accessed 9/3/2015)
- U.S. EPA. Safe Drinking Water Act (SDWA), webpage last updated by the U.S. Environmental Protection Agency on April 15, 2015a.
<http://water.epa.gov/lawsregs/rulesregs/sdwa/index.cfm> (accessed 9/3/2015)
- U.S. EPA. Drinking Water Science and Regulatory Support, webpage last updated by the U.S. Environmental Protection Agency on August 24, 2015b.
<http://water.epa.gov/drink/standards/hascience.cfm> (accessed 9/4/2015)
- U.S. EPA. Human Health Benchmarks for Pesticides, webpage last updated by the U.S. Environmental Protection Agency on September 4, 2015c.
<http://iaspub.epa.gov/apex/pesticides/f?p=HHBP:home> (accessed 9/4/2015)
- WHO. *Guidelines for Drinking Water Quality*, 4th ed. World Health Organization: Geneva, Switzerland, 2011.
http://www.who.int/water_sanitation_health/publications/dwq_guidelines/en/ (accessed 9/3/2015)
- WRRF. *Potable Reuse: State of the Science Report and Equivalency Criteria for Treatment Trains*. Project Number WRRF-11-02. WateReuse Research Foundation: Alexandria, VA, 2013.

Chapter 5

Source Control Program

The primary sources of wastewater from a community include discharges from residences and commercial, institutional, and public facilities. Other significant sources include industrial discharges and stormwater infiltration/inflow. Because of the diversity of these sources, the organic and inorganic constituents contained in wastewater can be variable. The National Pretreatment Program for commercial and industrial dischargers has reduced the discharge of many constituents that are difficult to manage from a treatment and environmental standpoint, but it has not eliminated the discharge of such constituents. Source control programs are designed to further control, limit, or eliminate the discharge of constituents into wastewater that can be difficult to treat or impair the final quality of treated wastewater intended for direct potable reuse (DPR). Topics addressed in this chapter include:

- What is the importance of a source control program for DPR?
- What is the National Pretreatment Program?
- What are the Federal Pretreatment Standards?
- What is the regulatory authority for a source control program?
- What is involved in the implementation of a source control program?
- What are the principal elements of a source control program?
- What are realistic expectations for a source control program?

5.1 Importance of a Source Control Program for Direct Potable Reuse

The National Pretreatment Program was established as part of the Clean Water Act (CWA) to control and regulate the discharge of pollutants from commercial and industrial dischargers of wastewater to publicly owned treatment works (POTWs) (U.S. EPA, 2011). Although beneficial, this federal program has not eliminated pollutant loadings from industrial sources; therefore, an important preventative approach to consider when pursuing and planning for DPR is the implementation of a rigorous source control program in conjunction with the National Pretreatment Program to eliminate or control the discharge of constituents that might impact the production of advanced treated water (ATW). Before discussing the development and elements of a source control program, it will be helpful to first review the National Pretreatment Program and Federal Pretreatment Standards.

5.2 Overview of the National Pretreatment Program

The objectives of the National Pretreatment Program include: (1) preventing the introduction of chemical constituents into a POTW that interfere with treatment operations or pass through the treatment process and are discharged to receiving waters; and (2) improving opportunities to recycle and reclaim municipal and industrial wastewaters and biosolids (U.S. EPA, 2011). POTWs that discharge to surface waters under a National Pollutant Discharge Elimination

System (NPDES) permit and meet the following requirements in 40 CFR 403.8 are required to develop pretreatment programs:

“Any POTW (or combination of POTWs operated by the same authority) with a total design flow greater than 5 million gallons per day (mgd) and receiving from Industrial Users pollutants which Pass Through or Interfere with the operation of the POTW or are otherwise subject to Pretreatment Standards will be required to establish a POTW Pretreatment Program unless the NPDES State exercises its option to assume local responsibilities as provided for in §403.10(e). The Regional Administrator or Director may require that a POTW with a design flow of 5 mgd or less develop a POTW Pretreatment Program if he or she finds that the nature or volume of the industrial influent, treatment process upsets, violations of POTW effluent limitations, contamination of municipal sludge, or other circumstances warrant in order to prevent Interference with the POTW or Pass Through.”

Because POTWs are not designed to treat toxic chemical constituents from industries or commercial businesses, the National Pretreatment Program was created to address the discharge of toxic constituents from nondomestic sources. In the National Pretreatment Regulations, industrial and commercial dischargers (i.e., nondomestic dischargers) are defined as industrial users (IUs). The U.S. Environmental Protection Agency (U.S. EPA) has established General Pretreatment Regulations (40 CFR, Section 403) that define the responsibilities for federal, state, and local government, as well as industries, to achieve specific pretreatment objectives (APAI, 2015).

For wastewater agencies not subject to the Federal Pretreatment Program, the local, state, or federal permitting authority may not, in some cases, require a POTW to implement an approved pretreatment program or a program that meets all federal requirements; however, an agency that intends to operate a DPR project should develop a source control program as the first barrier to protect ATW quality, even if it is not a permit requirement (APAI, 2015). The key elements of the National Pretreatment Program per 40 CFR 403.8(f) are summarized in Table 5.1.

5.3 Federal Pretreatment Standards

POTWs must enforce both general and specific prohibitions in the General Pretreatment Regulations. The regulations disallow an IU from discharging constituents that pass through or cause interference with the treatment process. Specific discharge prohibitions are referenced in Appendix D and include requirements for infrastructure protection (including the POTW collection system) and worker safety.

Categorical pretreatment standards (see Appendix E) include technology-based numeric limits or best management practices (BMPs) developed in accordance with Section 307 of the CWA to limit pollutant discharges to POTWs from specific process wastewaters. These national technology-based standards apply to an IU regardless of whether the POTW has an approved pretreatment program or the IU has been issued a control mechanism or permit. The standards are established based on the list of priority pollutants (APAI, 2015). Additional standards and requirements may be added by state and local regulatory agencies, as needed, to protect the POTW. After approval in accordance with 40 CFR 403.5(c), these local limits are also called Pretreatment Standards and are enforceable for the purposes of the CWA.

Table 5.1. Key Elements of the National Pretreatment Program

Element	Description
Legal authority	The POTW must have the legal authority to apply and enforce any pretreatment standards and requirements.
Procedures	The POTW must develop and implement procedures to ensure compliance with pretreatment standards and requirements, including procedures for: (1) receiving and analyzing self-monitoring reports and other notices submitted by IUs; (2) random sampling and analysis of effluent from IUs; and (3) conducting surveillance activities to identify compliance or noncompliance independently from information supplied by IUs.
Funding	The POTW (and multijurisdictional entities) must have sufficient resources and qualified personnel to carry out the authorities and procedures specified in its approved pretreatment program.
Local limits	The POTW must develop technically based local limits to regulate the discharge of pollutants of concern from IUs and address the specific needs and concerns of a POTW.
Enforcement response plan	The POTW must develop and implement an enforcement response plan that contains detailed procedures indicating how the POTW will investigate and respond to instances of industrial noncompliance.
List of IUs	The POTW must maintain a list of all IUs.

Notes: IU=industrial user; POTW=publicly owned treatment work.

Sources: U.S. EPA (2011) and APAI (2015).

5.4 Development of a Source Control Program for Direct Potable Reuse

Although not all POTWs are required to implement federal pretreatment programs, any municipality, utility, or agency pursuing a DPR project, regardless of size, should consider the impacts of industrial and commercial contributions on the wastewater supply.

In developing a source control program, it is essential to understand the sources of toxic compounds entering the sewershed from readily managed point sources. In some cases, to minimize the impact from large industrial dischargers, it may be appropriate to consider diverting highly industrialized discharges to alternative treatment facilities.

Any organization pursuing a DPR project should implement a source control program that is tailored to the individual service area and incorporates elements and BMPs presented in this chapter.

5.4.1 Goals of the Source Control Program

As shown in Figure 5.1, a multiple-barrier approach to potable reuse needs to include source control. Keeping constituents of concern (COCs) out of the wastewater system through a

robust source control program can be the most beneficial, efficient, and cost-effective strategy for managing and treating industrial, commercial, and other contributions to the wastewater supply.

Specifically, the goals of an effective source control program include:

- Minimize the discharge of potentially harmful or difficult-to-treat chemical constituents to the wastewater collection system from industries, health care facilities, commercial businesses, and homes.
- Improve wastewater effluent quality and advanced water treatment performance.
- Provide the public with confidence that the wastewater collection system is being managed with potable reuse in mind.

5.4.2 Regulatory Authority of the Source Control Program

A successful source control program should begin with the establishment of the regulatory authority to implement the program. As discussed in Section 5.2, many wastewater agencies are required to develop pretreatment programs through the National Pretreatment Program. These programs can be used as a foundation for establishing additional regulatory authority that targets potable reuse applications.

For wastewater agencies not required to participate in the National Pretreatment Program, the appropriate regulatory authority should consider elements similar to those contained in it, in addition to elements discussed in Section 5.5.

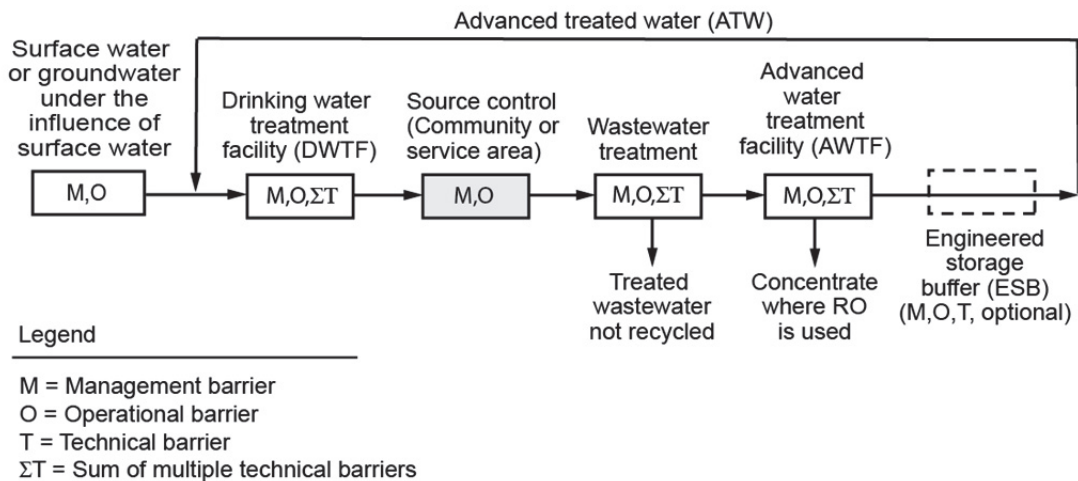

Figure 5.1. Key elements of the technical component of a potable reuse program.

Note: The source control element is shaded.

5.5 Principal Elements of a Source Control Program for Direct Potable Reuse

A key factor in creating an effective DPR program is to recognize that a source control program is a critical element in creating a safe water supply and not focused solely on wastewater compliance. Although the National Pretreatment Program provides a strong foundation, the focus of that program is not on potable reuse; therefore, it is recommended that additional elements be incorporated into a source control program for DPR projects.

The principal elements of an effective DPR source control program include: (1) regulatory authority; (2) monitoring and assessment of commercial and industrial dischargers to the wastewater collection system within the service area; (3) investigation of chemical and other constituent sources; (4) maintenance of the current inventory of chemical constituents; (5) preparation of a public outreach and participation program; and (6) preparation of a response plan for water quality deviations. A number of subtasks within each of these categories are delineated in Table 5.2.

Contractual agreements should also be in place between the entity responsible for the treatment and delivery of drinking water and the entity operating the wastewater collection and treatment system to ensure that source control elements will be implemented. Such agreements should address the allocation of costs.

5.6 Source Control Program Expectations

Expectations must be realistic regarding the effectiveness of source control. Source control programs are not designed to remove all unwanted constituents. What is important is the reduction of problematic constituents. The successful reduction of problematic constituents typically occurs under the following conditions:

- Constituent concentration levels are measurable.
- Contributing sources can be identified.
- Contributing sources are within the management agency's control.

5.6.1 Measurable Constituent Concentration Levels

Source control programs are most effective when the constituent is consistently found at measurable levels in the wastewater influent or collection system. If a constituent is found sporadically, it is often difficult to identify the source (APAI, 2015).

5.6.2 Ability to Identify Contributing Sources

The contributing source of constituents is typically identified most successfully when it is a single source or a group of similar sources accounting for most of the influent loading. The portion of the total influent source that is identified and considered controllable must be greater than the reduction in constituent levels needed. Substances like banned pesticides that homeowners may stockpile and occasionally flush down the drain are difficult to control, but potentially can be addressed through hazardous waste collection programs or public outreach (APAI, 2015).

Table 5.2. Principal Elements of an Enhanced Source Control Program for Direct Potable Reuse

Element	Description
Regulatory Authority	
Legal authority	Ensure that the source control program has sufficient legal authority to develop and implement source control measures, including authority for oversight/inspection, as well as plan and review new connections to the collection system.
Discharge permits	Ensure that industrial wastewater discharge permits and other control mechanisms can effectively regulate and reduce the discharge of COCs.
Enforcement	Ensure that the enforcement response program can identify and respond rapidly to discharges of COCs.
Alternative control programs	Consider alternative control mechanisms, such as BMPs or self-certification for zero discharge of pollutants, for classes of industries or commercial businesses.
Monitoring and Assessment of the Wastewater Collection System Service Area (Sewershed)	
Routine monitoring program	The influent to the WWTP and secondary or tertiary effluent sent to the AWTF are monitored routinely for regulated constituents and other COCs that may be discharged into the collection system service area.
Constituent prioritization program	COCs are identified and short-listed using results from the routine monitoring program. It may be necessary to develop separate monitoring programs for the constituents of greatest concern.
Evaluation of technically based local limits	Regulated constituents and other COCs are evaluated for their potential to cause interference, pass through an AWTF, or affect human and environmental health and safety. For the development of local limits, consider including a broader spectrum of COCs, such as (1) regulated and nonregulated constituents that are relevant for DPR (e.g., drinking water contaminants) or (2) CECs.
Source Investigations	
Industrial and commercial business inventory	Develop and maintain a frequently updated, comprehensive inventory of industries and businesses that may use products or chemicals containing COCs or generate intermediate COCs. For agencies with large service areas, multiple communities, or industrial flows coming from other wastewater entities, it may be desirable to link the inventory to a service area mapping tool such as a geographic information system network.
WWTP-AWTF joint response plan	The response plan includes a flow chart showing key responsibilities and decision points to either investigate or mitigate COCs being discharged into the collection system.

Maintenance of Current Inventory of Chemicals and Constituents

Chemical inventory program	Develop and maintain a database of the chemicals stored and inventory volumes used annually by industrial and commercial producers and manufacturers in the service area. Potential sources of this type of information include the industries themselves, State Emergency Response Commission, Local Emergency Response Commission, or local fire departments.
Waste hauler monitoring program	A program is needed to monitor and track discharges of septic wastes or other wastewater delivered to the collection system by truck. Haulers should be permitted and required to provide chemical inventory and discharge information to the wastewater treatment authority before being allowed to discharge. Consideration should be given to requiring waste haulers to deliver to a different treatment facility.
Chemical fact sheets	Maintain a database of fact sheets for COCs encountered within the service area.

Public Outreach Program

Industrial discharges	<ul style="list-style-type: none"> • Provide (1) public outreach information on DPR to industries; (2) source control practices; and (3) compliance assistance and permit assistance to support the DPR program. • Develop a program that encourages commercial and industrial dischargers to be partners in protecting the sewershed, such as environmental stewardship programs or award programs for consistent compliance. • Assist and encourage industries and businesses that use chemicals that contain COCs to identify source control options, such as chemical substitution.
Service area pollution prevention partnership program	Develop a cooperative program with cities, counties, or other jurisdictions within the WWTP service area to disseminate information to the public about COCs and acceptable discharges to the sewer.
Public education and outreach program	Provide outreach to the public regarding the proper disposal of pharmaceuticals and household products containing chemicals that may be difficult to treat (e.g., what to flush and not flush). Consider developing a household hazardous waste collection program.
Education program	Develop school educational programs for grades 1 through 12 that address source control issues related to potable reuse.

Response Plan for Identified Constituents

Interagency collaboration	The success of a source control program will depend on strong interagency cooperation and responsiveness between the WWTP and AWTF. For DPR projects that receive industrial waste from outside the service area, ensure that the agreement to accept the waste is consistent with source control program requirements. For DPR projects where the agency that administers the source control program is not the agency that operates the AWTF, consider entering into a memorandum of understanding or other contractual agreement so that appropriate source control actions can be taken, if necessary, to protect water quality.
---------------------------	--

Response to water quality deviations	Develop an action plan for responding to water quality deviations. For example, if a specific chemical constituent is detected at the AWTF, review operation and calibration records for online meters and any analytical methods that may be involved. If a problem is not identified, then notify the WWTP to initiate a review and inspection of the WWTP for possible sources of the constituent. If no source is found at the WWTP, then initiate a wastewater collection system sampling program. If a problem is identified, the action plan should include procedures for the operations staff to notify the source control staff to respond to and correct the issue and, if necessary, procedures for bypassing or shutting down the facility.
--------------------------------------	--

Notes: AWTF=advanced water treatment facility; BMP=best management practice; CEC=constituent of emerging concern; COC=constituent of concern; DPR=direct potable reuse; WWTP=wastewater treatment plant.

Sources: U.S. EPA (2011) and APAI (2015).

5.6.3 Contributing Sources within the Management Agency’s Control

In general, contributing sources of constituents within the jurisdiction of the wastewater management agency are easier to control than those outside of the agency’s jurisdiction. For example, industrial sources are controlled more easily because industries are regulated and required to meet collection system use permit requirements, whereas residential sources are not within the legal jurisdiction of wastewater agencies; therefore, voluntary behavioral changes are needed. If a constituent source is a commercial product, such as mercury thermometers, it may not be within the local agency’s power to ban or restrict the use of the product. To be effective, the use of a product must be restricted on a local, regional, statewide, or national basis. One example of a successful statewide effort is the statutory ban in California on the use of lindane in head lice products. The ban was accomplished based on the combined efforts of wastewater control agencies, a state legislator, and the National Pediculosis Association (APAI, 2015).

5.7 Example Source Control Programs Related to Potable Reuse

Many agencies have developed local or statewide “No Drugs Down the Drain” programs,⁶ drug take-back programs, and household hazardous waste collection programs. Other agencies have enhanced pretreatment program elements to augment their pollution prevention efforts. For example, the source control program used for the Groundwater Replenishment System (GWRS) in California⁷ includes proposed local limits for 1,4-dioxane, N-nitrosodimethylamine (NDMA), and constituents that adversely affect total organic carbon (TOC) removal, such as acetone (APAI, 2015). More information about the GWRS source control program is provided in Appendix F.

⁶ See <http://www.nodrugsdownthedrain.org/>.

⁷ An IPR project, GWRS uses treated wastewater effluent from the OCSD to produce ATW at the AWTF operated by OCWD. The sanitation district manages the source control program for GWRS.

5.8 References

- APAI. *Final Report: Direct Potable Reuse Resource Document*. Report prepared for the Texas Water Development Board by Alan Plummer Associates, Inc.: Fort Worth, TX, 2015.
http://www.twdb.texas.gov/publications/reports/contracted_reports/doc/1248321508_Vol1.pdf (accessed 9/3/2015)
http://www.twdb.texas.gov/publications/reports/contracted_reports/doc/1248321508_Vol2.pdf (accessed 9/3/2015)
- U.S. EPA. *Introduction to the National Pretreatment Program*, (EPA-833-B-11-001). Office of Wastewater Management: U.S. Environmental Protection Agency: Washington, DC, 2011.
http://water.epa.gov/polwaste/npdes/pretreatment/upload/pretreatment_program_intro_2011.pdf (accessed 9/3/2015)

Chapter 6

Wastewater Treatment

Wastewater treatment is the next step following source control in the development of a new potable water supply from collected wastewater flows. Historically, the principal focus of wastewater treatment has been to produce an effluent suitable for discharge to the environment. In the future, as potable reuse becomes more common, wastewater treatment plants (WWTPs) will be designed to produce an effluent optimized for further processing by advanced water treatment facilities (AWTFs). Until that time, several improvements can be made to existing WWTPs to improve the quality of effluent for subsequent advanced treatment. Aspects of wastewater treatment considered in this chapter include:

- What constitutes wastewater treatment?
- What are the differences between accepted secondary treatment processes?
- What are the issues related to the use of WWTP effluent in potable reuse applications?
- What are the benefits of using a higher quality effluent in a potable reuse treatment train?
- What are the potential impacts of climate change and water conservation?

6.1 Overview of Wastewater Treatment

The location of wastewater treatment in the implementation of a direct potable reuse (DPR) project is illustrated in Figure 6.1. As shown, wastewater treatment is the critical step required to produce water from wastewater that is suitable for processing in an AWTF. It is also the most cost-effective means for removing a number of constituents of concern (COCs). The goal of wastewater treatment, levels of treatment, and some examples of treatment trains are presented and discussed in Sections 6.1.1 to 6.1.3.

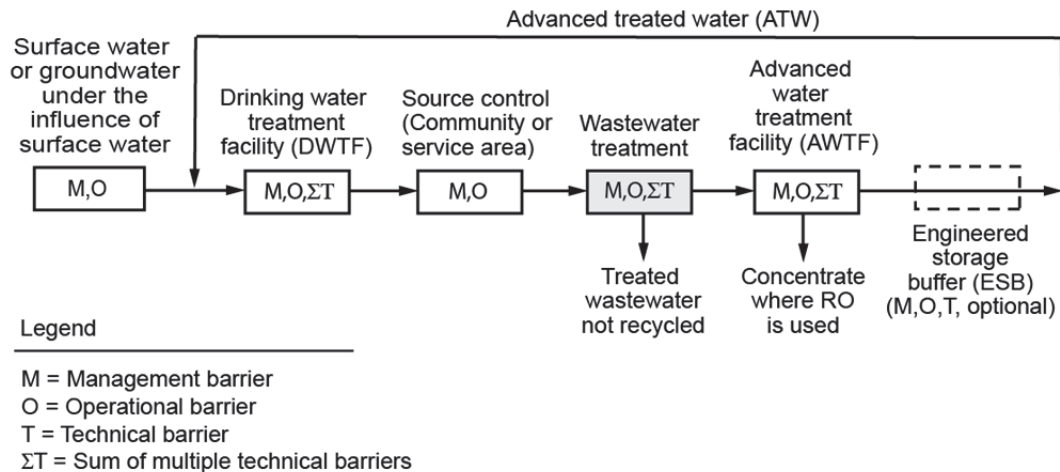

Figure 6.1. Key elements of the technical component of a potable reuse program.

Note: The wastewater treatment element is shaded.

6.1.1 Goal of Wastewater Treatment

The principal goal of wastewater treatment is to remove constituents so that treated effluent can be returned to the environment or reused safely. Specific treatment steps typically involve: (1) the removal of coarse and settleable constituents; (2) transformation of dissolved and particulate biodegradable constituents into acceptable end products; (3) incorporation of suspended and nonsettleable colloidal solids into a biological floc or biofilm; (4) transformation or removal of nutrients, such as nitrogen and phosphorus; (5) transformation or removal of trace organic constituents (TOCs); and (6) reduction of pathogenic microorganisms (Tchobanoglous et al., 2014). Wastewater treatment is accomplished through physical separation processes, such as screening and settling, as well as by accelerating natural biological processes that occur in the environment by providing a reactor with conditions to encourage the growth of a microbial community effective at removing organic constituents and reducing nutrient concentrations.

6.1.2 Levels of Wastewater Processing

To achieve the removal or inactivation of physical, chemical, and microbial constituents, a number of unit processes are grouped together to provide what is known as primary, secondary, tertiary, and advanced treatment (see Table 6.1).

Table 6.1. Levels of Wastewater Treatment

Treatment Level	Description
Preliminary	Removal of wastewater constituents (such as rags, sticks, floatables, grit, and grease) that may cause maintenance or operational problems with treatment operations, processes, and ancillary systems.
Primary	Removal of a portion of suspended solids and organic matter from wastewater.
Advanced primary	Enhanced removal of suspended solids and organic matter from wastewater, typically accomplished by chemical addition or filtration.
Secondary	Removal of biodegradable organic matter (in solution or suspension) and suspended solids. In federal regulations, secondary treatment is defined as meeting minimum standards for biochemical oxygen demand and total suspended solids and pH limits in effluents discharged from municipal wastewater treatment plants.
Secondary with nutrient removal	Removal of biodegradable organics, suspended solids, and nutrients (e.g., nitrogen, phosphorus, or both).
Tertiary	Removal of residual suspended solids (after secondary treatment), usually by granular media filtration or microscreens. Disinfection is often included in tertiary treatment, although it can be applied after any level of treatment prior to discharge. In some parts of the United States, nutrient removal also is included under this definition.
Advanced	Removal of dissolved, colloidal, and suspended materials remaining after secondary or tertiary treatment when required for various reuse applications.

Source: Tchobanoglous et al. (2014).

In general, the term *primary* refers to the application of physical unit processes, *secondary* refers to chemical and biological unit processes, and *tertiary* refers to the removal of residual fine solids following secondary treatment. In some parts of the United States, nutrient removal is also included within the definition of tertiary. When used as the final treatment process, both secondary and tertiary typically include disinfection. Because these terms are arbitrary, their use varies between states and regions. Also, these commonly used descriptors of wastewater treatment are not well suited to a discussion of DPR and, in most cases, are of little value. To understand wastewater treatment in the context of DPR, it is necessary to focus first on establishing the degree of constituent removal required (i.e., treatment or water quality) so that treated wastewater can be processed effectively in an AWWTF; and then select the unit treatment processes necessary to achieve the required degree of treatment.

6.1.3 Typical Examples of Wastewater Treatment Processes

The principal biological processes used for wastewater treatment can be divided into two main categories: suspended growth and attached growth (or biofilm) processes. Typical examples of commonly used biological treatment processes without and with effluent filtration are shown in Figures 6.2 and 6.3, respectively.

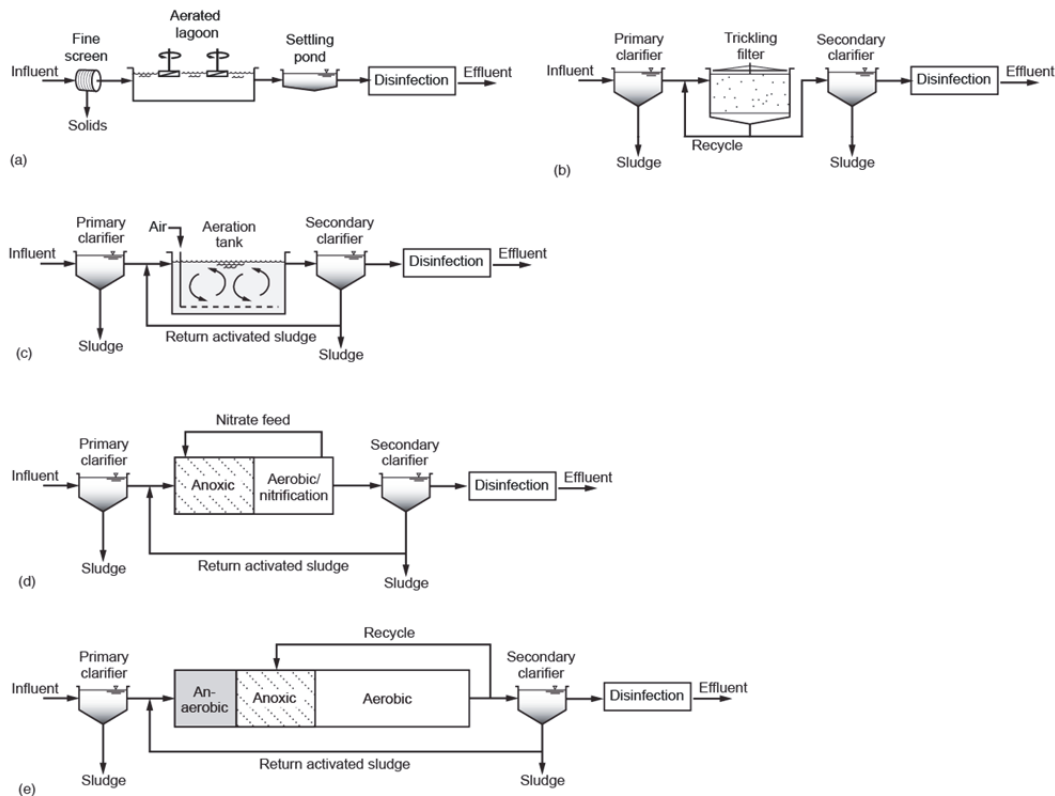

Figure 6.2. Generalized process flow diagrams for the typical treatment processes used for conventional wastewater treatment: (a) aerated lagoon for TSS and BOD removal; (b) trickling filter for TSS and BOD removal; (c) activated sludge for TSS and BOD removal and nitrification; (d) suspended growth biological treatment for TSS, BOD, and nitrogen removal; and (e) suspended growth biological treatment for TSS, BOD, nitrogen, and phosphorus removal.

Source: Adapted from Asano et al. (2007).

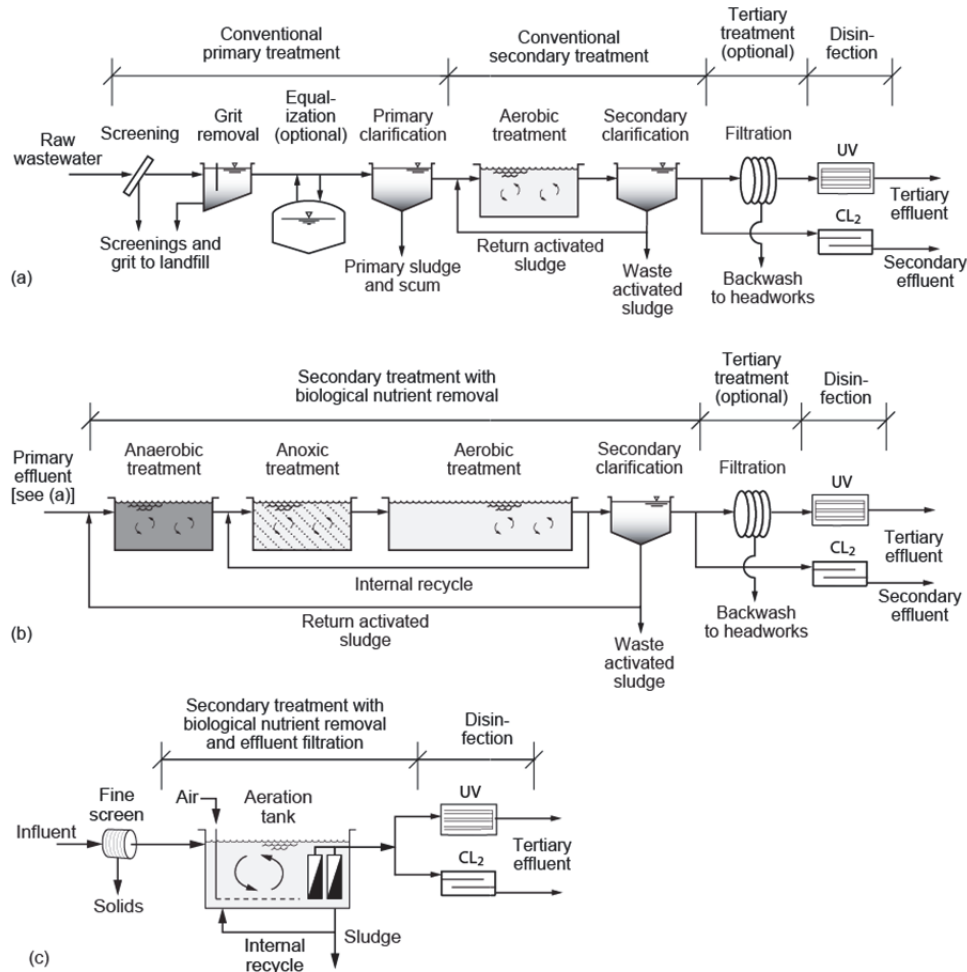

Figure 6.3. Generalized process flow diagrams for the typical treatment processes used for wastewater treatment with effluent filtration and disinfection: (a) activated sludge for TSS and BOD removal and nitrification; (b) suspended growth biological treatment for TSS, BOD, and nitrogen removal; and (c) membrane bioreactor with nitrification, nitrogen removal, or both, and effluent filtration.

Source: Adapted from Tchobanoglous et al. (2014).

The successful design and operation of the processes illustrated in Figures 6.2 and 6.3 require an understanding of the following: (1) the types of microorganisms involved; (2) specific reactions involved; (3) environmental factors that affect microbial performance, nutritional needs, and reaction kinetics; and (4) how these variables relate to the superior effluent quality that must be produced for advanced treatment for DPR. Details on these processes may be found in the literature (Tchobanoglous et al., 2014).

6.2 Differences in Wastewater Treatment Train Effluent Quality

The final water quality of the effluent from the wastewater treatment processes shown in Figures 6.2 and 6.3 will vary depending on the treatment steps included in the treatment train. Some representative data for the expected effluent quality from different wastewater treatment trains are reported in Table 6.2.

Table 6.2. Typical Range of Effluent Quality after Various Levels of Treatment

Constituent	Unit	Untreated Wastewater	Range of Effluent Quality after Indicated Treatment				
			Conventional Activated Sludge ^a	Conventional Activated Sludge with Filtration ^{a,b}	Activated Sludge with BNR ^b	Activated Sludge with BNR and Filtration ^c	Membrane Bioreactor
Total suspended solids	mg/L	130–389	5–25	2–8	5–20	1–4	<1–5
Turbidity	NTU	80–150	2–15	1–5	1–5	1–5	<1–2
Biochemical oxygen demand	mg/L	133–400	5–25	<5–20	5–15	1–5	<1–5
Chemical oxygen demand	mg/L	339–1016	40–80	30–70	20–40	20–30	<10–30
Total organic carbon	mg/L	109–328	20–40	15–30	10–20	1–5	<0.5–5
Ammonia nitrogen	mg N/L	14–41	1–10	1–6	1–3	1–2	<1–5
Nitrate nitrogen	mg N/L	0–trace	5–30	5–30	<2–8	1–8	<8 ^e
Nitrite nitrogen	mg N/L	0–trace	0–trace	0–trace	0–trace	0.001–0.1	0–trace
Total nitrogen	mg N/L	23–69	15–35	15–35	3–8	2–5	<10 ^d
Total phosphorus	mg P/L	3.7–11	3–10	3–8	1–2	≤1	<0.3 ^d –5
Volatile organic compounds	µg/L	<100–>400	10–40	10–40	10–20	10–20	10–20
Iron and manganese	mg/L	1–2.5	1–1.5	1–1.4	1–1.5	1–1.5	trace
Surfactants	mg/L	4–10	0.5–2	0.5–1.5	0.1–1	0.1–1	0.1–0.5
Total dissolved solids	mg/L	374–1121	374–1121	374–1121	374–1121	374–1121	374–1121
Trace constituents ^e	µg/L	10–50	5–40	5–30	5–30	5–30	0.5–20
Total coliform	No./100 mL	10 ⁶ –10 ¹⁰	10 ⁴ –10 ⁵	10 ³ –10 ⁵	10 ⁴ –10 ⁵	10 ⁴ –10 ⁵	<100
Protozoan cysts and oocysts	No./100 mL	10 ¹ –10 ⁵	10 ¹ –10 ²	0–10	0–10	0–1	0–1
Viruses	PFU/100 mL ^f	10 ¹ –10 ⁸	10 ¹ –10 ⁴	10 ¹ –10 ³	10 ¹ –10 ³	10 ¹ –10 ³	10 ⁰ –10 ³

Notes: ^aConventional secondary is defined as activated sludge treatment with nitrification; ^bBNR is defined as biological nutrient removal for removal of nitrogen and phosphorus; ^cwith anoxic stage; ^dwith coagulant addition; ^efor example, fire retardants, personal care products, and prescription and non-prescription drugs; ^fplaque-forming units.

Source: Tchobanoglous et al. (2014)

The differences in final water quality include nutrients, metals, microorganisms, and measurements of organic and solids concentrations. Note that the application of these data is more qualitative than quantitative. For example, higher organic loading in the effluent from a WWTP will result in increased downstream membrane fouling, though the exact correlation between changes in effluent BOD (as an example) and membrane flux is not quantified broadly.

6.3 Issues Related to the Use of Wastewater Treatment Plant Effluent in Potable Reuse Applications

The principal issue related to the use of existing WWTPs for the production of an effluent suitable for further advanced treatment is that WWTPs were not designed originally with that objective in mind. All the treatment processes shown in Figures 6.2 and 6.3 will meet secondary treatment standards; however, overall effluent quality will be different. Although there are numerous examples of existing AWTFs that produce ATW with varying degrees of secondary or tertiary wastewater quality, the role of the WWTP in a DPR project is to provide a consistent, high-quality effluent. Also, certain contaminants, such as pathogens, numerous CECs, and disinfection byproduct (DBP) precursors, may be removed more cost effectively through biological treatment. Although these removals have not been well documented in the past, studies are under way, so it is expected that a wastewater treatment system used in conjunction with an AWTF will be upgraded as necessary to optimize consistency, reliability, and product water quality.

6.3.1 Modification of Existing Treatment Processes

Modifying existing WWTPs for incorporation into potable reuse systems requires increased scrutiny and possible upgrades to the wastewater management infrastructure, along with related operation and management (O&M) activities. In general, WWTPs will need to be designed or modified to optimize overall performance, enhance reliability, and produce an effluent quality that is suitable as a feed water supply for an AWTF producing ATW.

6.3.2 Measures to Improve the Performance and Reliability of Treatment Processes

Measures that must be considered and possibly taken to improve performance and enhance the reliability of existing and proposed WWTPs include:

- More rigorous source control (as discussed in Chapter 5)
- Enhanced fine screening
- Influent flow equalization
- Eliminating untreated return flows
- Switching the operation mode of biological treatment processes to provide nutrient removal
- Converting to a suspended growth process
- Equalization of return flows
- Effluent filtration
- Disinfection
- More rigorous process performance monitoring

Each of these measures, considered further in Table 6.3, are recommended to enhance the reliability and success of a DPR project, but the specific improvement measure will depend on local needs (e.g., improved efficiency, water quality, or reliability) and constraints.

Table 6.3. Measures that Can Be Taken to Improve the Performance and Enhance the Reliability of Existing and Proposed WWTPs

Measure	Comments	Value of Each Measure ^a
Enhanced screening process and possibly fine screening (2 to 6 mm)	<ul style="list-style-type: none"> • Removal of inert constituents that can impede treatment performance (e.g., rags and plastic materials). • Alteration of wastewater particle size distribution, which enhances kinetics of biological treatment. 	Efficiency, reliability
Influent flow and load equalization	<ul style="list-style-type: none"> • Flow equalization can be used to enhance biological treatment by: (1) reducing or eliminating shock loadings; (2) diluting inhibiting substances; and (3) improving performance of overall biological treatment processes through improved consistency in solids, organics, and nutrient loading. • Biological treatment reactor sizes can be reduced with flow equalization. • Blower aeration and return flow rates and process controls are stabilized—requiring only minor adjustments—with flow equalization. • Surface area requirements for secondary effluent filtration are reduced and filter performance is improved with more consistent filtered water quality and uniform filter-backwash cycles. 	Efficiency, water quality, reliability
Elimination (or equalization) of untreated return flows	<ul style="list-style-type: none"> • Return flows are generated from solids thickening and dewatering processes. • All solids handling processes involve significant amounts of polymer to enhance dewatering process; some polymers have been identified as precursors to some disinfection byproducts (DBPs), such as N-nitrosodimethylamine (NDMA). • Return flows contain constituents that cause membrane fouling and can deteriorate performance of biological treatment process, including non-biodegradable nitrogenous compounds, recalcitrant colloidal material, and high ammonia concentrations. If return flows cannot be completely eliminated by discharging them to a downstream facility, then they should be flow equalized and aerated or treated separately. • In most WWTPs, return flows are introduced during daytime hours, which concentrates loading from these streams and deteriorates plant performance. • If return flows must be processed, then they should be equalized and returned to the treatment process during late evening and early morning hours when excess treatment capacity is available. 	Water quality, reliability

Measure	Comments	Value of Each Measure ^a
Operational mode for biological treatment process	<ul style="list-style-type: none"> To enhance performance of AWTF, biological treatment plants should be operated in nitrification/denitrification mode. Longer mean cell residence times can be used to remove nutrients and enhance removal of trace organic chemicals (Salveson et al., 2012) and other specific constituents, such as metals. 	Water quality, reliability
Effluent filtration and disinfection	<ul style="list-style-type: none"> Effluent filtration should be added to improve effluent quality and ensure consistency. Effluent filtration can help minimize downstream impacts from biological upset in the secondary process. 	Water quality, reliability
Improved online process monitoring	<ul style="list-style-type: none"> Facility should evaluate online meters for maintaining solids inventory, in addition to monitoring effluent water quality with turbidity and conductivity monitors. A meter maintenance procedure must be in place, with dedicated staff to ensure that meters are calibrated properly and checked periodically with laboratory measurements and action points are identified (a flow chart of responsibility is also necessary). 	Water quality, reliability
Improved process monitoring	<ul style="list-style-type: none"> Enhanced monitoring of individual processes to improve performance. Special studies of new process monitoring equipment and techniques. 	Water quality, reliability

Notes: ^aEfficiency=recommended improvement increases overall cost efficiency of operation; water quality=recommended improvement increases final potable water quality; reliability=recommended improvement increases overall reliability of treatment train; AWTF=advanced water treatment facility; mm=millimeter; WWTP=wastewater treatment plant.

Source: Adapted in part from Tchobanoglous et al. (2011).

6.4 The Value of Higher Quality Secondary Effluent and Tertiary Treatment for Potable Reuse Applications

Different qualities of secondary effluent have been used successfully in a number of indirect potable reuse (IPR) projects. Examples include:

- Orange County Water District (OCWD), which receives a blend of 20% trickling filter effluent and 80% nitrified effluent from the Orange County Sanitation District (OCSA).
- West Basin Municipal Water District, which receives non-nitrified effluent from the City of Los Angeles’s Hyperion WWTP.
- Surface water augmentation facilities at the Upper Occoquan Service Authority in Fairfax County, VA and Wayne Hill Water Resources Center in Gwinnett County, GA, both of which provide biological treatment with nutrient removal.

Properly designed advanced treatment processes such as microfiltration (MF), reverse osmosis (RO), advanced oxidation process (AOP), and others, as discussed in Chapter 7, can be used to overcome most water quality challenges, but higher quality secondary and tertiary effluent will improve the overall performance of these advanced water treatment processes.

6.4.1 Benefits of Enhanced Treatment

The principal benefits of increased levels of secondary treatment (which may involve nutrient removal, filtration, disinfection, or both filtration and disinfection) include: (1) reduced contaminant load and, therefore, reduced demands on subsequent treatment processes; (2) enhanced performance of advanced treatment processes; and (3) increased reliability of the overall treatment train. Examples of the benefits of nitrification in the secondary treatment process are discussed in Section 6.4.2; the benefits of effluent filtration and disinfection are discussed in Section 6.4.3.

6.4.2 Benefits of Nitrification and Denitrification

Membrane filtration produces a water quality suitable for feeding directly into an RO process. In a system that is operating properly (i.e., fibers are not compromised or broken), the membrane filter produces a water quality that is low in turbidity and silt density index (SDI), a measure of treatability, with TSS below the detection limit. Membrane filters are susceptible to operational issues depending on the type of biological treatment provided upstream. It has been demonstrated that fouling rates for a UF membrane increased by a factor of nearly 10 if the biological treatment process was operated in a non-nitrifying or conventional mode. The observed fouling condition was attributed largely to colloidal organics greater than 10,000 Daltons (Trussell et al., 2009). Denitrification also has the added benefit of reducing the degree of nitrate removal that must be achieved in the AWTF.

As an example, the OCWD commissioned the Groundwater Replenishment System (GWRS) using non-nitrified secondary effluent from the OCSO in 2008. Two years later, OCSO completed operational changes to enable its facility to produce a nitrified effluent from the activated sludge process (currently, GWRS feed water is approximately 80% activated sludge and 20% trickling filter effluent). These operational changes translated to a significant reduction in the fouling rate of the full-scale MF system, as shown in Figure 6.4. GWRS has been operating with reduced membrane fouling since the conversion to a mostly nitrified feed water supply.

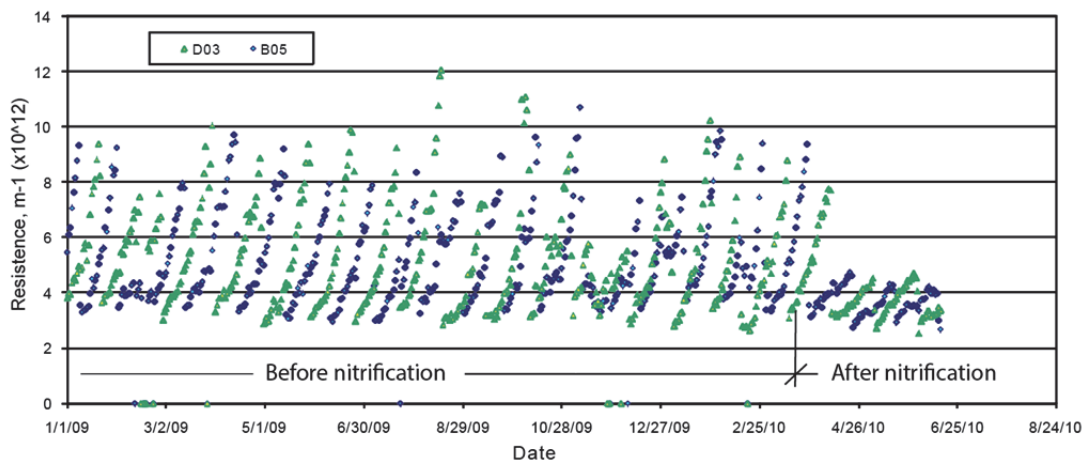

Figure 6.4. Observed reduced membrane fouling and operating pressures for the Groundwater Replenishment System operated by the Orange County Water District after changes were made in March 2010 to allow a nitrification mode at the Orange County Sanitation District.

Source: Graphic courtesy of OCWD.

6.4.3 Benefits of Effluent Filtration and Disinfection

Treatment beyond secondary, which can include filtration, disinfection, or both (tertiary treatment), can be used to enhance the probability that a high-quality feed water will be delivered to the AWTF. Tertiary treatment can also be used to reduce a measure of complexity and the effects of close-coupled processes in DPR systems. For potable reuse treatment trains, it must be recognized that the treatment processes are both complex and close-coupled (the performance of a process in the series can affect the performance of the subsequent process or processes). These two factors have been identified as key contributors to engineering failures (Salveson et al., 2014). A biological process upset that increases the suspended solids and turbidity of secondary effluent will impact downstream membrane performance, but the impact will be reduced with the use of tertiary filtration to capture and reduce the particle load. The disinfection of secondary or tertiary filtered effluent can add a redundant disinfection barrier to the subsequent advanced treatment train, with the level of redundancy and a possible measure of robustness depending upon the disinfection technology. The benefits of several technologies are identified in Table 6.4. Although chloramination has a biocidal role in membrane treatment processes, it is not included in the table because of its lack of virus or protozoa disinfection at reasonable CT values (i.e., the chlorine residual, C, mg/L multiplied by the contact time, T, minutes) (U.S. EPA, 1990).

6.5 Impacts of Climate Change and Water Conservation

When planning DPR projects, the potential impacts of climate change and water conservation should be considered in addition to issues related to treatment.

6.5.1 Climate Change

The most immediate impacts of climate change are reflected in abnormal fluctuations in temperature, evaporation rates, snow melt, increased irrigation requirements, and rainfall events. Of greater concern to wastewater treatment is the short duration and intensity of rainfall events brought about by climate change. The impacts of extreme rainfall events (Tchobanoglous et al., 2014) include:

- Flood events that exceed the capacity of existing collection systems.
- Increased pumping costs.
- Discharge of untreated stormwater runoff (from combined collection systems).
- Damage to collection system infrastructure.
- Flooding of WWTPs.
- Washout of biological treatment processes at WWTPs.
- Flows beyond the capacity of WWTP disinfection facilities.

The potential washout of biological treatment processes may necessitate the addition of effluent filtration for the protection of a downstream AWTF. Because the intensity of rainfall events can be expected to continue in the future, planning efforts should be undertaken to assess how to best adapt to these changes, especially where potable reuse is to be implemented. Studies also have shown that extreme rainfall events can adversely influence membrane systems operating on biological effluents (Trussell et al., 2009).

Table 6.4. Benefits in Improved Water Quality and Pathogen Reduction Derived from Filtration and Disinfection after Secondary Treatment

Treatment	Water Quality Improvement	Pathogen Reduction	Notes
Sand filtration with chemical addition	Reduction in TSS and turbidity	Deep bed filtration could be engineered and operated similar to drinking water filtration systems. Meeting turbidity standards of <0.3 NTU results in 2.5-log reduction of protozoa and 2-log reduction of virus (U.S. EPA, 1998). Upper Occoquan Sewage Authority (UOSA) facility is an example of this type of operation (USOA, no date).	Sand filtration systems not using chemical addition and attaining the listed turbidity reductions should not receive disinfection credits.
Disc filtration	Reduction in TSS and turbidity	<1-log reduction based upon limited research (Linden et al., 2012).	No notes.
Disinfection with free chlorination	Limited	Depending upon CT, free chlorine can provide 4+ log reduction of virus and some reduction of <i>Giardia</i> (U.S. EPA, 1990).	Free chlorine will increase DBP formation, which must be accounted for during advanced treatment.
UV light at low dose	Limited	Depending upon dose, UV can provide 4+ log reduction of virus, bacteria, and protozoa (U.S. EPA, 2006).	Tertiary UV disinfection often is not operated at doses sufficiently high enough for chemical oxidation.
UV light at high dose	destruction of trace chemicals	UV can provide 4+ log reduction of virus, bacteria, and protozoa (U.S. EPA, 2006). Based on new research, 6+ log reduction of virus may be achieved with high-dose UV systems used for DPR projects.	High-dose UV systems typically will be used in conjunction with the addition of an oxidant (e.g., H ₂ O ₂ or NaOCl) to result in an AOP.
Ozone	Destruction of trace chemicals, improvement to water clarity and quality (Trussell et al., 2015)	Depending upon CT, ozone can provide 4+ log reduction of virus and some reduction of <i>Giardia</i> (U.S. EPA, 1990; Trussell et al., 2015).	Ozone can form DBPs, including bromate and NDMA (Trussell et al., 2015). Subsequent treatment must address these constituents.
Pasteurization	Limited	6+ log reduction of virus and bacteria (Fontaine and Salveson, 2014; Salveson and Goel, 2014; SWRCB, 2014).	Time and temperature relationships govern performance, similar to the CT concept.

Notes: AOP=advanced oxidation process; CT=chlorine residual multiplied by contact time, mg/L/min; DBP=disinfection byproduct; DPR=direct potable reuse; NDMA=N-nitrosodimethylamine; TSS=total suspended solids; UV=ultraviolet.

6.5.2 Decrease in Per Capita Flow Rates

Other factors that will affect wastewater treatment and impact the future of DPR projects are water conservation, decentralized recycled water plants, and the use of graywater systems. To be specific, they will impact the quantity and composition of raw wastewater.

6.5.2.1 Water Conservation

Since about 1992, per capita indoor water use has been decreasing. Current per capita indoor domestic water use in the United States is about 60 gal/capita•d. By 2030, the rate is anticipated to decrease to 45 gal/capita•d or less, which will result in a corresponding decrease in per capita wastewater flow rate (Raucher and Tchobanoglous, 2014). Similar reductions also have occurred in the commercial, institutional, and industrial sectors. For example, as a result of drought conditions and conservation efforts in California, current water use in San Francisco is approximately 44 gal/capita•d. Because the amount of wastewater will continue to decrease as a result of conservation and water saving devices, care must be taken in the selection of future flow rates for planning purposes. In some locations where a significant fraction of water is used outdoors or lost from the collection system, enough wastewater may not be available to meet potential potable reuse demands. The decrease in per capita flow rates has also caused a significant increase in the concentration of wastewater constituents, which has impacted many older biological treatment facilities with inadequate aeration capacity.

6.5.2.2 Upstream Decentralized Wastewater Systems

Decentralized wastewater systems are used to treat wastewater at or near the point of waste generation and reuse. Individual decentralized systems can be used for water reclamation and reuse for applications such as landscape irrigation, toilet flushing, cooling applications, and water features (Tchobanoglous et al., 2014). The use of decentralized systems is predicated on the assumption that the existing collection system can be used for the transport of solids and reduced flow. The potential reduction in the quantity of wastewater available for potable reuse must be considered when evaluating the potential for DPR programs and whether decentralized facilities should be allowed.

6.5.2.3 Individual Graywater Systems

The increased use of graywater systems, especially in the arid West (including urban areas), will impact both per capita flow rates and the composition and concentration of the wastewater. For areas subject to extreme drought, the highest and best use of water may dictate a return of that water for potable rather than graywater use. At present, it is difficult to predict how important the use of graywater systems may be with respect to the quantity and composition of wastewater.

6.6 References

Asano, T.; Burton, F. L.; Leverenz, H.; Tsuchihashi, R.; Tchobanoglous, G. *Water Reuse: Issues, Technologies, and Applications*. McGraw-Hill: New York, 2007.

Fontaine, N.; Salveson, A. *Testing Results of the Pasteurization Demonstration Unit at the Ventura WRF*. Prepared for the City of Ventura and the Pasteurization Technology Group by Carollo Engineers: Walnut Creek, CA, 2014.

- Linden, K.; Salveson, A.; Thurston, J. *Innovative Treatment Technologies for Reclaimed Water*. Project Number WRF-02-009, WateReuse Research Foundation: Alexandria, VA, 2012.
- Raucher, R.; Tchobanoglous, G. *The Opportunity and Economics of Direct Potable Reuse*, WateReuse Research Foundation: Alexandria, VA, 2014.
- Salveson, A.; Goel, N. *Spot Check Bioassay Test Report for the Pasteurization System in Graton, California*. Prepared for the City of Graton and the Pasteurization Technology Group by Carollo Engineers: Walnut Creek, CA, 2014.
- Salveson, A.; Rauch-Williams, T.; Dickenson, E.; Drewes, J.; Drury, D.; McAvoy, D.; Snyder, S. *Trace Organic Compound Indicator Removal during Conventional Wastewater Treatment*. Water Environment Research Foundation: Alexandria, VA, 2012.
- Salveson, A.; Salveson, M.; Mackey, E.; Flynn, M. *Application of Risk Reduction Principles to Direct Potable Reuse*. Project Number WRRF-11-10. WateReuse Research Foundation: Alexandria, VA, 2014.
- SWRCB. Letter Regarding Approval of Graton Pasteurization System, State Water Resources Control Board, Sacramento, CA: August 13, 2014,
- Tchobanoglous, G.; Leverenz, H.; Nellor, M. H.; Crook, J. *Direct Potable Reuse: A Path Forward*. WateReuse Research Foundation: Alexandria, VA, 2011.
- Tchobanoglous, G.; Stensel, H. D.; Tsuchihashi, R.; Burton, F. L. *Wastewater Engineering: Treatment and Resource Recovery*, 5th ed. Metcalf & Eddy/AECOM, McGraw-Hill: New York, 2014.
- Trussell, R. R.; Salveson, A.; Snyder, S. A.; Trussell, R. S.; Gerrity, D.; Pecson, B. M. *Equivalency of Advanced Treatment Trains for Potable Reuse*. Project Number WRRF-11-02. WateReuse Research Foundation: Alexandria, VA. Draft, to be published in 2015.
- Trussell, R. S.; Jang, N.; Merlo, R.; Kim, I. S.; Hermanowicz, S. W.; Jenkins, D. Changes in Mixed Liquor and Organic Foulant Properties Affect Membrane Fouling for Non-Nitrifying and Nitrifying Biological Conditions. *Water Environ. Res.* **2009**, *81*, 255–264.
- UOSA. Upper Occoquan Sewage Authority, webpage not dated.
<http://www.uosa.org/IndexUOSA.asp> (accessed 9/3/2015)
- U.S. EPA. *Guidance Manual for Compliance with the Filtration and Disinfection Requirements for Public Water Systems Using Surface Water Sources*. Prepared by Malcolm Pirnie, Inc. and HDR Engineering, Inc., U.S. Environmental Protection Agency: Washington, DC, 1990.
- U.S. EPA. *Interim Enhanced Surface Water Treatment Rule*. 40 CFR Parts 141 and 142, *Fed Regist*, 63 (241), 69,477–69,521, 1998.
- U.S. EPA. *Ultraviolet Disinfection Guidance Manual for the Final Long Term 2 Enhanced Surface Water Treatment Rule*. EPA 815-R-06-007, Office of Water (4601), U.S. Environmental Protection Agency: Washington, DC, 2006.

Chapter 7

Advanced Water Treatment

The cornerstone of a potable reuse system, whether direct potable reuse (DPR) or indirect potable reuse (IPR), is the advanced water treatment facility (AWTF) used to produce advanced treated water (ATW) from treated wastewater. Over the past 10 years, a number of new or refined technologies have been developed for the advanced treatment of wastewater. Using these technologies, it is now possible to develop treatment trains (assemblages of treatment processes) to achieve a variety of treatment objectives, including the production of ATW. Issues related to the production of ATW considered in this chapter include:

- What is the purpose of advanced water treatment?
- What are typical examples of treatment trains used for advanced water treatment?
- What is a critical control point (CCP) and how is it used?
- What is an engineered storage buffer (ESB) and how is it used?
- What are the performance levels for advanced treatment processes, including the determination of pathogen log reduction credit?
- What is the reliability of various treatment trains based on redundancy, robustness, and resiliency of the individual treatment technologies?
- What happens to flows when the AWTF must be taken offline?

7.1 Overview of Advanced Water Treatment

The purpose and implementation of advanced water treatment are discussed in Sections 7.1.1 and 7.1.2. The AWTF is necessary to produce ATW from treated wastewater that is suitable as a water supply source for both groundwater and surface water augmentation. The location of the AWTF in the implementation of a DPR project with ATW is illustrated in Figure 7.1.

7.1.1 Purpose of Advanced Water Treatment

The purpose of advanced water treatment is to produce ATW from treated wastewater that meets all applicable federal, state, and local potable reuse regulations to serve as a water supply source. The principal concerns with treated wastewater are pathogens and chemical constituents (see Chapter 4). Treated wastewater from a wastewater treatment plant (WWTP) has measurable pathogens (Rose et al., 2004; Olivieri et al., 2007) and trace-level constituents (Trussell et al., 2015). Pathogen levels in secondary effluent present a public health threat and must be reduced substantially. Many chemical constituents have regulated values [e.g., the Maximum Contaminant Level (MCL) for nitrate] that must be met through the advanced treatment process. In most cases, trace levels of nonregulated chemical constituents—typically found in the $\mu\text{g/L}$ or ng/L level—have been shown to be below health significance levels (Trussell et al., 2015); however, reasons exist to provide further treatment for chemical constituents, such as to increase public confidence in DPR and as a precaution against unknown constituents in treated wastewater.

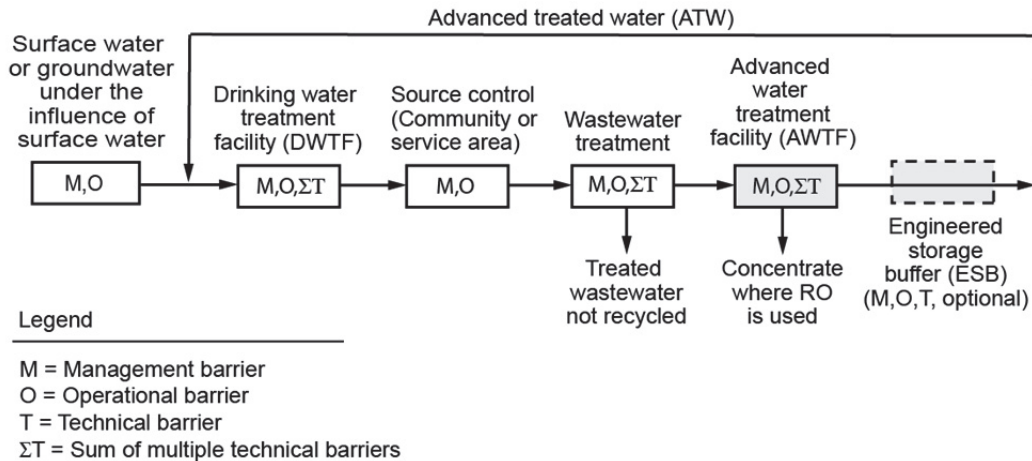

Figure 7.1. Key elements of the technical component of a potable reuse program.

Note: The advanced water treatment and ESB elements discussed in this chapter are shaded.

7.1.2 Implementation of Advanced Water Treatment

To date, ATW projects have been developed on the basis of: (1) laboratory analyses; (2) bench-, pilot-, and full-scale-testing; and (3) data from published literature. The extent to which each source of information is used is site specific and depends on local circumstances.

7.1.2.1 Design Based on Comprehensive Data Collection Program

Sampling schemes and bench- and pilot-scale testing can all be used to better understand pathogen and chemical constituent concentrations for a particular application. For instance, monthly sampling, spanning 1 to 2 years, for protozoa and virus in raw and secondary effluent will provide greater confidence in the measured levels of pathogens in the incoming wastewater and the variability (or lack thereof) of treatment by the primary and secondary processes. Sampling for a range of regulated and unregulated chemical constituents can guide the engineering team in determining the need for specific types of targeted treatment or improved wastewater source control. As an example, the design of the AWTF for the Groundwater Replenishment System (GWRS)—an indirect potable reuse (IPR) project operated by the Orange County Water District (OCWD) in California—was based on an extensive data collection program, which included bench-, pilot-, and full-scale demonstration testing and analysis.

7.1.2.2 Design Based on Limited Data

Because of unforeseen events such as droughts, DPR programs may have to be undertaken with limited long-term data. If limited data are available on pathogens or chemical constituents for a particular application, data from published technical literature can be used to develop conservative estimates of the concentrations of pathogens required for treatment. Industry literature and treatment performance data can be used in a similar way to conservatively estimate the treatment necessary for chemical constituent reduction. Extensive industry literature was summarized as part of WaterReuse Research Foundation (WRRF) Project 11-02 (Trussell et. al, 2015; NWRI, 2013; Trussell et al., 2013), resulting in a comprehensive, spreadsheet-based planning tool for estimating potable reuse treatment train

performance and cost. For facility design that is based on a literature review, extensive startup, performance, and water quality testing should be conducted after the construction of the AWWTF, but before ATW is used.

7.2 Treatment Technologies and Trains Used for Advanced Water Treatment

The focus of this section is on (1) the treatment processes used to remove specific constituents and (2) the treatment functions and groupings of a number of technologies to achieve a specific treatment goal. The performance and implementation of these technologies are considered in subsequent sections.

7.2.1 Treatment Technologies

Over the past 10 years, substantial work has been completed to advance the performance and understanding of processes for the advanced treatment of water, including improvements in systems such as:

- Microfiltration (MF) and ultrafiltration (UF) to remove residual particulate matter
- Reverse osmosis (RO), electrodialysis, and distillation to demineralize and remove chemical constituents
- Advanced oxidation processes (AOPs) to remove specific constituents. These processes could include: (1) ozonation alone or with hydrogen peroxide; (2) ultraviolet (UV) disinfection alone or with hydrogen peroxide or sodium hypochlorite; and (3) other combinations of ozone (O₃) and UV to accomplish photolysis, oxidation, or both from high levels of hydroxyl radical production

Principal technologies currently used for advanced treatment are summarized in Table 7.1.

Table 7.1 Summary of Technologies for Advanced Water Treatment

Treatment Option	Use/Description
Filter screens (FS)	Used to remove any large suspended solids in unfiltered and filtered secondary effluent. Filter screens are needed to protect downstream membranes.
Flow equalization (FE)	Used to eliminate diurnal flow rate variations, reduce the size of downstream units, and reduce variations in water quality. Constant flow with consistent water quality to the advanced treatment process reduces wear and tear on equipment (e.g., stress cracks in equipment from cycling) and results in improved performance.
Ozone/ biologically active filtration (O ₃ /BAF)	O ₃ followed by BAF can be used as a pretreatment step before MF or UF to achieve a reduction in pathogenic microorganisms and condition treated secondary effluent to enhance the performance of downstream processes, such as MF and UF. It has been demonstrated that O ₃ /BAF ahead of MF/UF provides a greater benefit than O ₃ /BAF after MF/UF, but ahead of RO (Trussell et al., 2015). In some cases, the use of O ₃ /BAF may eliminate the need for RO for advanced water treatment.
Microfiltration (MF)	Used to remove residual suspended particles by mechanical sieving. Typical membrane pore size range is 0.07 to 2.0 micrometers (µm).

Treatment Option	Use/Description
Ultrafiltration (UF)	Used to remove residual suspended particles by mechanical sieving. Typical membrane pore size range is 0.008 to 0.2 μm . UF is often used in place of MF.
Cartridge filtration (CF)	Used to remove suspended and colloidal impurities from chemicals added to prevent fouling on RO membranes. Typical filter cartridge pore size range is 5 to 10 μm .
Electrodialysis (ED)	Process used to remove salt from solution by the use of selective membranes.
Nanofiltration (NF)	Used to remove residual suspended particles and polyvalent cations by mechanical sieving. Typical membrane pore size range is 0.001 to 0.02 μm . NF has been used in place of RO when only softening or partial demineralization is needed.
Pasteurization	Used to heat water to a specified temperature and time to kill or inactivate microorganisms.
Reverse osmosis (RO)	Used to remove residual salts and colloidal and dissolved solids, including trace organics, by means of size exclusion and solution/diffusion. Typical membrane pore size range is 0.0001 to 0.002 μm .
Advanced oxidation process (AOP)	Used to destroy or alter chemical constituents that are not oxidized completely by conventional biological treatment processes or removed by filtration. AOP may contain a range of processes, but most commonly uses O_3 with hydrogen peroxide or UV with hydrogen peroxide. More recent projects are implementing UV with sodium hypochlorite for AOP. The use of UV, O_3 , and sodium hypochlorite also provides disinfection benefits.
Post-processing	When RO is used, post-processing typically involves decarbonation and stabilization. Decarbonation is used to remove (i.e., strip out) carbon dioxide from the RO product water to increase pH and reduce the amount of chemicals added to stabilize it. Stabilization involves the addition of a chemical (typically lime) to the RO product water to reduce its corrosive properties. A variety of different indices (e.g., Aggressiveness Index, Langelier Saturation Index) are used to assess the stability of the product water.
Engineered storage buffer (ESB)	A storage facility used between the AWTF and DWTF. In some cases, travel time in the pipeline from the AWTF to the DWTF may serve the same purpose.

Notes: AWTF=advanced water treatment facility; DWTF=drinking water treatment facility; UV=ultraviolet.

Source: ^aAdapted in part from Tchobanoglous et al. (2014).

7.2.2 Examples of Typical Treatment Trains

For AWTFs, a number of different treatment processes are grouped together to remove the particulate, colloidal, and dissolved inorganic and organic constituents found in the effluent from WWTPs or other water sources. Although many of the treatment processes can be used to remove particulate and colloidal constituents, only specific treatment processes remove total dissolved solids (TDS) and specific target constituents. The grouping of technologies to achieve a specific treatment objective is known as a treatment train. Examples of treatment trains are shown in Figure 7.2 and described in Sections 7.2.2.1 and 7.2.2.2.

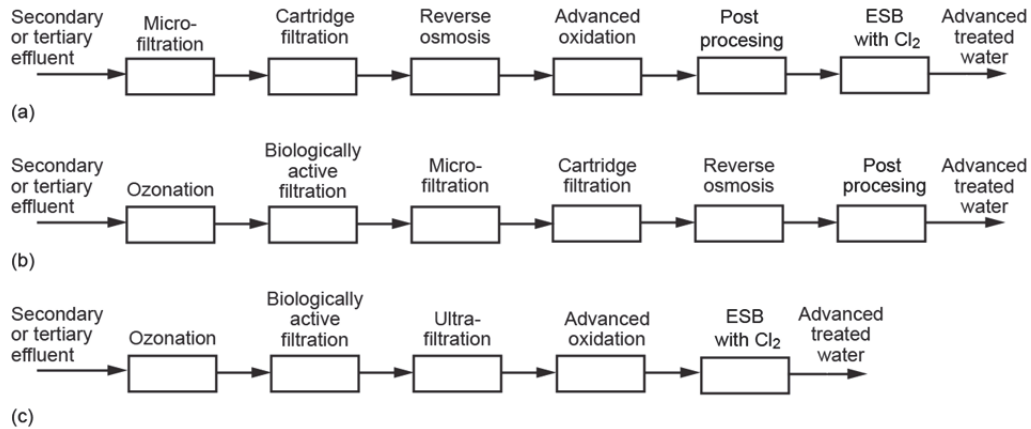

Figure 7.2. Three typical advanced water treatment trains for the production of ATW: (a) treatment train employing microfiltration, reverse osmosis, advanced oxidation, and engineered storage buffer with free chlorine; (b) treatment train employing ozone with biologically active filtration, microfiltration, reverse osmosis, and advanced oxidation; and (c) treatment train employing ozone with biologically active filtration, ultrafiltration, advanced oxidation, and engineered storage buffer with free chlorine.

7.2.2.1 Treatment Trains with Reverse Osmosis

With the exception of the ESB with free chlorine, the treatment train shown on Figure 7.2(a) – which includes RO – is representative of the process configuration employed currently by OCWD’s AWTF for the production of ATW for groundwater augmentation (see Figures 2.3 or 11.1). The treatment train shown in Figure 7.2(b) is a modification of the treatment train shown in Figure 7.2(a) with the addition of ozone with biologically active filtration (BAF) to achieve additional oxidation and the biodegradation of constituents, gain disinfection credit, and improve MF performance. Another benefit of additional treatment is less reliance on other treatment processes for pathogen reduction and the potential reduction in size or need for the ESB (with or without free chlorine).

7.2.2.2 Treatment Trains without Reverse Osmosis

Because of cost and logistical issues associated with managing RO concentrate, especially in inland locations, interest exists in developing treatment trains capable of removing or converting chemical constituents without physically separating them from product water. The treatment train shown in Figure 7.2(c) employs ozone with BAF, UF, AOP, and ESB with free chlorine, but eliminates the RO step. The lack of TDS removal and a higher level of TOC

in the effluent are the principal differences between the RO-based treatment trains shown in Figures 7.2(a) and 7.2(b) and the treatment train shown in Figure 7.2(c). In terms of DBP formation, the impact of the difference in TOC can be determined through pilot- or bench-scale testing.

7.2.3 Representative Performance for the Treatment Train

With respect to public health protection, the goal of advanced water treatment is to minimize risk through the destruction and removal of specific chemical constituents and pathogens. To meet this goal, AWTF treatment trains should be designed to eliminate acute risks (best exemplified by pathogens) and minimize potential chronic risks (best exemplified by chemical constituents) (Salveson et al., 2014).

Treated wastewater contains a number of chemical constituents, many of which are known to be of public health concern and are regulated under the Clean Water Act (CWA) and Safe Drinking Water Act (SDWA) (see Chapter 4 and Appendix G). Although the overall quality of the ATW produced at AWTFs will vary depending on the processes included in the treatment train, all the treatment trains are capable of meeting existing regulatory requirements. Some representative data for the quality of ATW produced from different treatment trains are reported in Table 7.2. The differences in final water quality will include solids concentrations, organics, nutrients, metals, and microorganisms. As with the corresponding data reported in Section 6.2, the application of these data is more qualitative than quantitative.

7.3 Process Control for Water Quality Assurance

Because some constituents are difficult to monitor directly (e.g., pathogens) and others lack analytical methods (e.g., many chemicals), indirect measures will be needed to ensure the AWTF is performing properly and ATW will meet water quality requirements. Two approaches that have been developed are: (1) the use of critical control points (CCPs); and (2) response retention time storage. Both approaches are discussed in Sections 7.3.1 and 7.3.2.

7.3.1 Critical Control Points for Water Quality Assurance

A CCP is a point in advanced water treatment where: (1) control can be applied to an individual unit process to reduce, prevent, or eliminate process failure; and (2) monitors are used to confirm the control is functioning correctly. CCPs are individual treatment processes that provide control for pathogens (including the provision of log reduction credits) and chemical constituents. They are supplemented with operational control points to manage other unit processes not used for pathogen or chemical control. The CCP concept is based on the hazard analysis and critical control point (HACCP) system. A simplified risk assessment and CCP approach can provide meaningful pathogen and chemical control in a DPR system.

CCP monitoring would include a set of alarms with alert levels and critical limits that are supported by a relationship to the water quality if those critical limits are exceeded. A simplified approach would be to measure the performance of a given CCP against a single metric or surrogate (e.g., conductivity, TOC, UV₂₅₄, and turbidity). A detailed monitoring approach would have an alert level in which trending is used to assess system performance, but the product water quality remains within an acceptable level. Example CCPs for an AWTF treatment train, along with corresponding monitoring requirements, are listed in Table 7.3.

Table 7.2. Typical Range of Effluent Quality after Various Levels of Advanced Water Treatment

Constituent	Unit	Untreated Wastewater	Range of Effluent Quality after Indicated Treatment			
			Conventional Activated Sludge with Filtration	Activated Sludge with O ₃ /BAF	Activated Sludge with MF and RO	Activated Sludge with MF, RO, and UV-AOP
Total suspended solids	mg/L	130–389	2–8	1–2	≤1	≤1
Turbidity	NTU	80–150	1–10	≤1	≤0.1	≤0.1
Biochemical oxygen demand	mg/L	133–400	<5–20	≤1	≤1	≤1
Chemical oxygen demand	mg/L	339–1016	30–70	≤10–30	≤2–10	≤2–10
Total organic carbon	mg/L	109–328	15–30	2–5	0.1–1	0.1–1
Ammonia nitrogen	mg N/L	14–41	1–6	≤1	≤1	≤1
Nitrate nitrogen	mg N/L	0–trace	5–30	5–30	≤1	≤1
Nitrite nitrogen	mg N/L	0–trace	0–trace	≤0.001	≤0.001	≤0.001
Total nitrogen	mg N/L	23–69	15–35	≤1	≤1	≤1
Total phosphorus	mg P/L	3.7–11	2–6	2–6	≤0.5	≤0.5
Volatile organic compounds	µg/L	<100–>400	10–40	≤1	≤1	≤1
Iron and manganese	mg/L	1–2.5	1–1.4	≤0.3	≤0.1	≤0.1
Surfactants	mg/L	4–10	0.5–1.5	≤0.5	≤0.1	≤0.1
Totals dissolved solids	mg/L	374–1121	374–1121	374–1121	≤5–40	≤5–40
Chemical constituents ^a	µg/L	10–50	5–30	≤0.1	≤0.1	≤0.1
Total coliform	No./100 mL	10 ⁶ –10 ¹⁰	10 ³ –10 ⁵	350	<1	<1
Protozoan cysts and oocysts	No./100 mL	10 ¹ –10 ⁵	0–10	≤0.002	≤0.002	≤0.002
Viruses	PFU/100 mL	10 ¹ –10 ⁸	10 ¹ –10 ⁴	≤0.03	≤0.03	≤0.03

Notes: ^aFor example, fire retardants, personal care products, and prescription and nonprescription drugs; AOP=advanced oxidation process; BAF=biologically active filtration; MF=microfiltration; O₃=ozone; PFU=plaque-forming units; RO=reverse osmosis; UV=ultraviolet.

Source: Adapted from Tchobanoglous et al. (2014).

Table 7.3. Examples of Pathogen Treatment Critical Control Points for a Typical AWTF Treatment Train

CCP	CCP Monitor	Concerns
Primary and secondary treatment	No currently defined CCP monitor. WRRF Project 14-02 ^a may address this issue through correlations of pathogens to indicator bacteria concentrations.	Online virus and protozoa testing are not viable. Online measurement of bacteria removal (or concentrations) is possible, allowing some measure of secondary effluent microbiological quality.
MF	Daily Pressure Decay Testing. Typical values <0.3 psi/min to demonstrate membrane integrity.	Online turbidity measurement is insufficient to prove membrane integrity. PDT is typically performed daily, so ESB with sufficient storage is required to obtain protozoa reduction credits.
RO	Online EC or Online TOC. Log reduction of EC or TOC across the RO process to demonstrate a minimum level of pathogen removal.	Removal of salts (e.g., EC or TOC) provides confidence in a minimum level of pathogen removal. With enhanced monitoring of the RO process, including the use of fluorescent dyes, it may be possible to increase the log reduction credits based upon better confidence in RO performance.
UV-AOP	Intensity sensors. Following U.S. EPA (2006b) or other methods, online intensity monitoring demonstrates disinfection dose delivery.	Minimal concerns if properly calibrated sensors are used following U.S. EPA guidelines.
ESB	Online Cl₂. Online residual to document CT value ^b and disinfection in accordance with U.S. EPA (1990).	Minimal concerns. Disinfection credit based upon extended storage and free chlorine residual CT values.

Notes: ^aWRRF Project14-02, Establishing Additional Log Reduction Credits for WWTPs; ^bThe chlorine residual, C, mg/L multiplied by the contact time, T, minutes; AOP=advanced oxidation process; CCP=critical control point; EC=electrical conductivity; ESB=engineered storage buffer; MF=microfiltration; PDT=pressure decay testing; RO=reverse osmosis; TOC=total organic carbon; UV=ultraviolet.

Source: Salveson et al. (in press).

For DPR, the CCP concept has been detailed in the following WRRF project reports:

- WRRF 09-03, Utilization of Hazard Analysis and Critical Control Points Approach for Evaluating Integrity of Treatment Barriers for Reuse (Halliwell et al., 2014), which discusses the use of the HACCP approach for a water system and the process to identify CCPs.
- WRRF 12-06, Guidelines for Engineered Storage for Direct Potable Reuse (Salveson et al., in press), which includes CCP-based monitoring and sizing.
- WRRF 13-03, Critical Control Point Assessment to Quantify Robustness and Reliability of Multiple Treatment Barriers of DPR Scheme (Walker et al., in press).

7.3.2 Response Retention Time Storage

For DPR projects, the elimination of acute risk from pathogen exposure is imperative. Treatment trains for the production of ATW will have multiple barriers for pathogen reduction, but these treatment trains should receive treatment credit only if performance can be measured accurately before the release of ATW. This concept is detailed in WRRF Project 12-06 (Salveson et al., in press). For treatment processes with precise and accurate online monitoring, high levels of pathogen credits can be assigned; however, for processes that have periodic sampling for performance monitoring, pathogen credit cannot be obtained unless the ATW is held for a specific amount of time, known as the failure response time (FRT) (Salveson et al., in press).

7.4 The Role of the Engineered Storage Buffer

The use of an ESB is optional, as noted in Figure 7.1. Costs and benefits derived from the use of an ESB can be weighed against the cost of adding additional treatment units. The required FRT and sizing of an ESB are considered in Sections 7.4.1 and 7.4.2.

7.4.1 Failure Response Time

FRT is defined as the maximum possible time from when a failure occurs in the treatment system to when the system has been corrected such that the quality of the final product water is no longer affected by the failure. Specifically, FRT is a sum of the sampling interval and turnaround time for the process-specific CCP, system turnaround time, and system correction time (see Figure 7.3). For a potable reuse treatment scheme, overall FRT is based upon the treatment process with the highest individual FRT.

For a unit process monitored by a traditional sampling technique, the sampling interval may be daily (e.g., for total coliform) or quarterly [e.g., for trace organic contaminants (TOCs)]. The sample turnaround time will vary by method of analysis and can take from hours to days to weeks. With continuous online monitoring, the sampling turnaround time could be compressed to a range from seconds to minutes.

The system turnaround time is dependent on both technical and institutional factors. For example, if the Supervisory Control and Data Acquisition (SCADA) system for an AWTF is set up to divert water automatically or bring on a backup process in response to failure, the system turnaround time could be as short as a few minutes; however, if human intervention is required (e.g., operator intervention or manager approval), the system turnaround time might increase to several hours or days.

The system correction time, which can include increasing the dose, closing valves, verifying performance, and putting the AWWTF back into service, will depend on the configuration of the treatment processes.

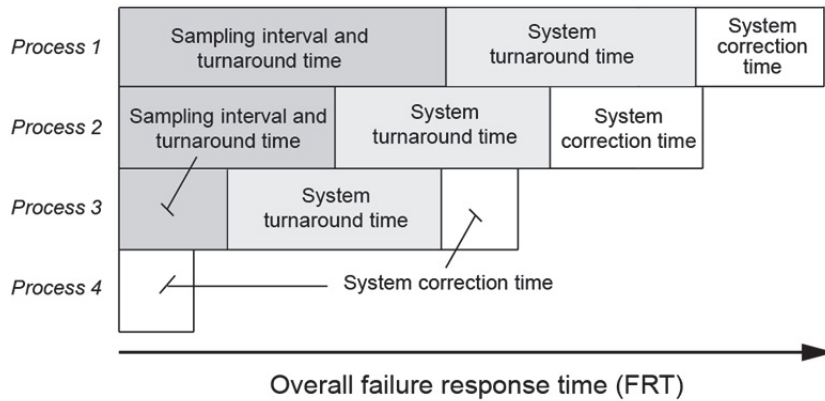

Figure 7.3. Different process failure response times, depending on the sampling interval and turnaround time, system turnaround time, and system correction time.

7.4.2 Sizing the Engineered Storage Buffer

The ESB should be sized to hold water for the entirety of the FRT, ensuring ATW does not leave the AWWTF unless in full compliance with operational and regulatory parameters. Several configurations can be used for the ESB to achieve the required FRT, including plug-flow pipelines, baffled tanks, or tanks in parallel operated in a fill, store, and draw mode.

Under the proposed ESB framework, the log reduction credits achieved by any process are the minimum of the potential credit based on the actual process efficiency and the credit that can be confirmed based on the sensitivity of the monitoring technique used (i.e., method sensitivity). The log reduction credits can only be given if the FRT for that unit process is less than the storage time provided by the ESB. For DPR, it may be more economical to not take credit for a particular process because it would require excessive ESB storage times. Instead, additional treatment that results in short (or no) ESB storage times may be preferred.

7.5 Design Considerations for Advanced Water Treatment

The principal design objectives for AWWTFs include the elimination of acute risk achieved through pathogen removal, reduction of chronic risk achieved through the removal of specific chemical constituents, and ability to reliably achieve these goals. Each of these topics is discussed in Sections 7.5.1 to 7.5.3.

7.5.1 Pathogen Reduction

Enteric viruses, *Cryptosporidium*, and *Giardia* are the waterborne pathogens of greatest concern with respect to human exposure through drinking water and the potential for infection. Several approaches have been proposed to estimate the pathogen treatment reduction levels necessary to adequately protect public health (NWRI, 2013; CDPH, 2014). The key steps to determine the necessary level of pathogen treatment, as documented in NWRI (2013), include:

- Set the risk-based standard for pathogen concentrations in water. The recommended levels were based on the assumption that the 1 in 10,000 annual infection threshold was an acceptable risk
- Conservatively estimate the number of pathogens in raw wastewater
- Calculate the required log reduction from raw wastewater to reduce pathogens to the determined level, resulting in 12-log reduction for virus, 10-log reduction for protozoa, and 9-log reduction for bacteria

Lesser pathogen reductions are required if secondary effluent is used as the pathogen starting point and sufficient data exist to support the analysis, as is the case for the DPR projects in Big Spring and Wichita Falls, TX. Because the focus of this framework document is on DPR, the lost value of the environmental buffer (i.e., response time and, in some cases, treatment) must be accounted for through additional treatment, advanced monitoring schemes, or both. As mentioned in Section 7.4, treatment credit for any particular process is provided if the performance of that process can be verified within the determined FRT. If the cost or footprint does not allow the use of an ESB, then additional treatment with continuous online monitoring may be required to meet pathogen reduction standards.

7.5.1.1 Advanced Water Treatment Facility Pathogen Reduction Credits

The ability of a wide range of treatment processes to meet chemical and pathogen standards for ATW production (reviewed within this chapter and Chapter 4) have been demonstrated and are well documented (Trussell et al., 2015; Salveson et al., in press). The findings from these studies regarding pathogen removal by individual treatment technologies can be applied to the treatment trains illustrated in Figures 7.2(a) and 7.2(c) and as described in Tables 7.4a and 7.4b. The following examples assume that 100% of the treatment credit is obtained from the AWTF and does not include the additional benefit of a subsequent DWTF. Using 12-log reduction for virus and 10 -log reduction for protozoa (which also results in the necessary 9 -log reduction for bacteria), the following conclusions can be made regarding the performance of the two treatment trains described in Tables 7.4a and 7.4b:

- **Treatment Train 7.2(a)** meets the virus, *Giardia*, and *Cryptosporidium* targets, but requires an extended ESB to allow for MF performance monitoring and, therefore, MF credit for protozoa reduction. If a shortened ESB is needed or desired, then another form of treatment would be required to increase protozoa credit. Other treatment options exist, such as the use of a chemically enhanced filtration system that meets U.S. EPA (1991, 2004) criteria, chlorination, or ozonation.
- **Treatment Train 7.2(c)**, which is similar to Treatment Train 7.2(a), with the exception of TDS removal, meets the virus, *Giardia*, or *Cryptosporidium* targets, but also requires the use of an ESB.

For any of the three treatment trains shown in Figure 7.2 and the two analyzed in Tables 7.4a and 7.4b, modifications could be made to reduce the level of treatment, but the ATW would be directed to a drinking water treatment facility (DWTF) for blending with other raw water supplies and final treatment. One example would be a “conventional” DWTF consisting of media filtration (including chemical addition) followed by free chlorination. The log reduction credits given by the U.S. EPA for the filtration process include: (1) 2-log reduction of virus, and (2) 2.5-log reduction of *Giardia* and *Cryptosporidium*, if the filter effluent

turbidity is <0.3 NTU 95% of the time (U.S. EPA, 2004). Free chlorine disinfection can be used to provide an additional 3-log reduction of virus (U.S. EPA, 2003). Overall, the conventional DWTF could provide a 5-log reduction of virus and 2.5-log reduction of protozoa.

7.5.1.2 Drinking Water Treatment Facility Pathogen Reduction Credits

Because treatment at a DWTF is needed for ATW, the pathogen treatment credit from the DWTF could then be added to the overall log reduction calculations. Pursuant to the U.S. EPA Surface Water Treatment Rule (SWTR) and Enhanced Surface Water Treatment Rule (ESWTR), DWTFs treating surface water or water under the influence of surface water must meet a 4-log reduction of virus and a 2 or more log reduction of *Cryptosporidium* (depending on the source water quality).

A wide range of treatment technologies are employed by DWTFs, including ozone, UV, membranes, chlorination, and media filtration (with chemical pretreatment). DWTF treatment processes used in conjunction with a DPR project should be detailed and credited with their specific performance. As an example, if the DWTF provides 4-log reduction of virus and 3-log reduction of *Cryptosporidium*, the additional log credits needed for virus and protozoa would be 8- and 7-log reduction, respectively. The difference in the needed log reduction credits would be provided by the AOTF used to produce ATW from secondary effluent.

7.5.2 Chemical Constituents

Regulated chemical constituents and unregulated TOxCs are the principal chemical constituents of concern (COCs) in ATW. The use of TOC as a surrogate measure is of interest from a monitoring standpoint. The use of AOPs to remove specific TOxCs, which has been mandated in California for the production of ATW, is also an important design consideration. These subjects are considered in Sections 7.5.2.1 to 7.5.2.4.

7.5.2.1 Regulated Chemical Constituents

Chemical constituents, including DBPs, industrial chemicals, pesticides, metals, and other classes known to be detrimental to human health at certain concentrations, are regulated in drinking water by the U.S. EPA under the SDWA through MCLs; therefore, any treated wastewater effluent that is proposed for water supply augmentation should be tested for the full suite of these constituents. A number of research studies have found that secondary or tertiary treated effluents meet most, if not all, MCLs without further treatment (Trussell et al., 2013). The fact that MCLs are met does not mean that additional treatment is not warranted for chemical constituents, such as that provided by the advanced treatment trains reviewed in this framework document.

Table 7.4a. Pathogen Log Reduction Credits Achieved by the Two Different Treatment Trains Shown in Figure 7.2

Process	Performance Monitoring Method	Log Reduction Credits ^a			Notes and References
		V	G	C	
Treatment Train 7.2(a) from Figure 7.2					
Primary and secondary treatment	No existing method	NC	NC	NC	No data exist that correlate secondary effluent water quality (e.g., BOD, turbidity, or TSS) with pathogen reduction. As such, no credit for treatment is granted for DPR applications.
MF	Daily PDT	0	4.0	4.0	CDPH (2011) documents the protozoa rejection ability of MF, which is commonly approved at 4 log. PDTs are required every 12 hours, resulting in a minimum of 12 hours of ESB storage to allow credit for protozoa reduction.
RO	Online TOC	1.5	1.5	1.5	The California DDW granted a 1.5-log reduction credit for all pathogens (i.e., virus, <i>Giardia</i> , and <i>Cryptosporidium</i>) for RO (WRD, 2013). Both EC and TOC can be used as conservative surrogates for RO pathogen reduction performance.
AOP	Intensity sensors	6	6	6	UV systems can provide 4-log reduction of adenovirus at 186 mJ/cm ² (U.S. EPA, 2006b). Extrapolation to 6-log reduction results in a minimum UV dose of 235 mJ/cm ² .
ESB with free Cl ₂ (CT = 900 mg•min/L)	Online Cl ₂	6	3	0	ESB is sized for 15 hours, resulting in 900 minutes of contact time with a free chlorine residual of 1 mg/L. U.S. EPA (2003) documents virus and <i>Giardia</i> kill for various pH and temperature values. A 6-log reduction of virus is extrapolated from maximum 4-log reduction documentation in U.S. EPA (2003) caused by high sensitivity of virus to free chlorine, whereas 3-log reduction of <i>Giardia</i> is not extrapolated.
Total for Treatment Train 7.2(a)		13.5	14.5	11.5	

Notes: ^aV=Virus, G=*Giardia*, C=*Cryptosporidium*; AOP=advanced oxidation process; BOD=biochemical oxygen demand; CDPH=California Department of Public Health; DDW=Division of Drinking Water; DPR=direct potable reuse; ESB=engineered storage buffer; CT=contact time of chlorine, mg/L/min; MF=microfiltration; NC=no credit; PDT=pressure decay testing; RO=reverse osmosis; TOC=total organic carbon; TSS=total suspended solids; UV=ultraviolet.

Table 7.4b. Pathogen Log Reduction Credits Achieved by the Two Different Treatment Trains Shown in Figure 7.2

Process	Performance Monitoring Method	Log Reduction Credits ^a			Notes and References
		V	G	C	
Treatment Train 7.2(c) from Figure 7.2					
Primary and secondary treatment	No existing method	NC	NC	NC	See notes for Treatment Train 7.2(a).
O ₃ (minimum CT = 1 mg•min/L)	Online O ₃	5	3	0	Assuming a temperature of 15°C or higher, <i>Giardia</i> reduction is 3 log at a CT of 0.95 mg/min/L (U.S. EPA, 2003). At the same temperature, 4-log reduction of virus occurs at a CT of 0.6 mg/min/L (U.S. EPA, 2003). A 5-log virus disinfection approval for ozone disinfection is based upon a minimum CT of 1.0 mg/min/L (Ishida et al., 2008). Trussell et al. (2015) documented similar virus kill. Both projects consistently demonstrated 7+ log reduction of seeded MS2. Such log reduction of MS2 is conservatively equivalent to 5-log reduction of poliovirus (Ishida et al., 2008; Fontaine and Salveson, 2014a).
BAF	None	0	0	0	BAF is used to degrade ozone DBPs and further polish the water.
UF	Daily PDT	1	4	4	CDPH (2011) documents the protozoa rejection ability and virus rejection ability of UF, which commonly is approved at 1 and 4 log, respectively. PDTs are required every 12 hours, resulting in a minimum of 12 hours of ESB storage to allow credit for removal.
AOP	Intensity sensors	6	6	6	See notes for Treatment Train 7.2(a).
ESB with free Cl ₂ (CT = 900 mg•min/L)	Online Cl ₂	6	3	0	ESB is sized for 15 hours, resulting in 900 minutes of contact time with a free chlorine residual of 1 mg/L.
Total for Treatment Train 7.2(c)		18	16	10	

Notes: ^aV=Virus, G=*Giardia*, C=*Cryptosporidium*; AOP=advanced oxidation process; BAF=biologically active filtration; CDPH=California Department of Public Health; CT=contact time for chlorine in mg/L/min; DBP=disinfection byproducts; ESB=engineered storage buffer; MS2=bacteriophage; PDT=pressure decay testing; UF=ultrafiltration.

Conventional DBPs, like trihalomethanes (THMs), haloacetic acids (HAAs), and bromate, are regulated by the Stage 1 and Stage 2 Disinfectant and Disinfection Byproduct Rules (U.S. EPA, 1998, 2006a). Blending ATW with a conventional raw water supply may decrease DBP formation through the DWTF (Steinle-Darling, 2015). This concept is being examined in Water Research Foundation Project 4536, which will evaluate the impacts of treatment and blending different water qualities, consequences of blending in different locations, and impacts of blending on the ESB design. The subject of blending is addressed in Chapter 8.

7.5.2.2 Unregulated Trace Organic Constituents

In addition to the chemical (and radiological) constituents regulated through MCLs, a number of unregulated TOrCs can also be found in wastewater, including pharmaceuticals, ingredients in personal care products, consumer chemicals, coatings (e.g., perfluorinated compounds), flame retardants, and others—some of which have endocrine-disrupting, carcinogenic, or other potentially harmful health effects if found at sufficiently high concentrations (Salveson et al., 2010; Trussell et al., 2015).

Extensive research has been conducted on the attenuation of these constituents through conventional WWTPs and their further breakdown during advanced water treatment (Baronti et al, 2000; Lovins et al., 2002; Schäfer et al., 2005; Sedlak and Kavanaugh, 2006; Steinle-Darling et al., 2010; Linden et al., 2012; Salveson et al., 2010, 2012; Snyder et al., 2012; and many others). An example data set for the existence and removal of a range of TOrCs through two different advanced water treatment trains (O₃/BAF/UV and MF/RO/UV-H₂O₂, from Trussell et al., 2015) is presented in Table 7.5.

Table 7.5. Examples of Trace Constituent Removal by Different Advanced Treatment Trains, per Trussell et al. (2015)

Constituent	Concentrations (ng/L)								
	Health Criteria	MRL	Secondary Effluent	Treatment Train 1			Treatment Train 2		
				O ₃ Effluent	BAF Effluent	UV Photolysis Effluent	MF Filtrate	RO Permeate	UV-H ₂ O ₂ Effluent
Atenolol	4000	3	292	<MRL	<MRL	<MRL	NT	<MRL	<MRL
Carbamazepine	10,000	1	194	<MRL	25	21	NT	<MRL	<MRL
DEET	200,000	6	45	<MRL	<MRL	<MRL	NT	<MRL	<MRL
Estrone	320	31	<MRL	<MRL	<MRL	<MRL	NT	<MRL	<MRL
Meprobamate	200,000	3	380	158	178	170	NT	<MRL	<MRL
PFOA	400	9	12	10	35	22	NT	<MRL	<MRL
PFOS	200	8	<MRL	<MRL	<MRL	<MRL	NT	<MRL	<MRL
Primidone	10,000	7	4100	525	323	186	NT	7	75
Sucralose	150,000,000	77	24,800	17,200	19,700	21,700	NT	<MRL	<MRL
TCEP	5000	77	<MRL	<MRL	<MRL	<MRL	NT	<MRL	<MRL
Triclosan	2,100,000	8	128	<MRL	<MRL	9	NT	<MRL	<MRL

Notes: BAF=biologically active filtration; DEET=N,N-diethyl-meta-toluamide; MF=microfiltration; MRL=method reporting limit; NT=not tested; PFOA=perfluorooctanoic acid; PFOS=perfluorooctane sulfonate; RO=reverse osmosis; TCEP=tris (2-Carboxyethyl) phosphine) hydrochloride; UV=ultraviolet.

7.5.2.3 Use of Trace Organic Carbon as a Surrogate Measure

Based on the results of the studies cited in Section 7.5.2.2 and others, it has been concluded that, with the exception of a small number of constituents that are difficult to treat by both conventional and membrane-based treatment, the vast majority of TOrCs in wastewater effluent (if present at all) are at concentrations not of concern to human health (Trussell et al., 2013).

In its Groundwater Recharge Regulations, California has established a TOC limit of 0.5 mg/L (CCR, 2015). The purpose of the TOC limit is to provide a surrogate for the concentration of all organic chemical constituents, including TOrCs, which can be achieved with existing approaches. This low level of TOC is readily attained using RO membranes (often resulting in TOC levels of 0.3 mg/L or less), but is more difficult to attain with other technologies. The TOC concentration in secondary effluent can vary widely, depending upon treatment process selection and operational parameters. For example, in a recent ozone pilot-testing study, TOC values ranged from about 5 mg/L for a highly treated secondary effluent to about 7 mg/L for membrane bioreactor (MBR) filtrate to more than 13 mg/L for a conventional secondary effluent (Trussell et al., 2015). The reduction in TOC by the O₃/BAF process ranged from 27 to 50% (Trussell et al., 2015).

7.5.2.4 Use of Advanced Oxidation for Specific Trace Organic Constituents

Some chemicals are partially removed by both conventional and membrane-based treatment (e.g., NDMA and 1,4-dioxane). Commonly formed during treatment (i.e., chloramination), NDMA is considered to be a DBP, whereas 1,4-dioxane is more of a local concern related to specific industrial activity in the community or service area of the publicly owned treatment works (POTWs). Both of these compounds are known to cause health effects at sufficient doses, but do not have enforceable concentration standards in drinking water (i.e., neither have MCLs, though NDMA has a notification level of 10 ng/L in California). For 1,4-dioxane and similar compounds, the Division of Drinking Water (DDW) of the California State Water Resources Control Board (SWRCB) has specified that an AOP must be incorporated into the advanced treatment process following RO treatment for the destruction of these compounds (CDPH, 2014). The AOP must be able to reduce 1,4-dioxane (or other suitable surrogates) by 0.5 log.

In Windhoek, Namibia, where the longest-operating DPR project is located, concerns about contamination with industrial chemicals led to the segregation of industrial from municipal wastewater, with municipal wastewater being used only for DPR. If complete segregation is not possible, an active source control program for industrial constituents should become standard practice (see Chapter 5).

7.5.3 Reliability of Treatment

Reliable treatment is a measure of the ability of a system to distribute water that meets all requirements protective of public health and includes design, operation, maintenance, and source control. The reliable production of ATW depends upon the use of redundant, robust, and resilient treatment technologies, as described in Table 7.6.

Table 7.6. Reliable Treatment Based on Redundancy, Robustness, and Resiliency

Term	Definition as Pertaining to DPR	Notes
Redundancy	The use of multiple unit processes to attenuate the same type of constituent.	More unit processes in series, even with reduced individual performance, can result in improved overall performance.
Robustness	The combination of technologies that address a broad variety of constituents.	Broad spectrum treatment is required because wastewater is the source water.
Resiliency	The ability to adapt successfully or restore performance rapidly in the face of treatment failures and threats.	Includes the ability to correct single- or multiple-process performance failures.

Note: DPR=direct potable reuse.

Source: Adapted from Pecson et al. (2015).

7.6 Contingency Plans for Advanced Water Treatment Facility Flow Rate Interruptions

AWTFs, as noted in Section 7.5.3, must be designed to provide robust, redundant, and resilient treatment with precise and accurate process monitoring to ensure reliable treatment. The goal is to eliminate process failures while maximizing the ATW production run time; however, there will be occasions where processes fail and the AWTF must be shut down to stop the release of noncompliant water. A catastrophic process failure may necessitate going offline for some time period. The potential for a failure of the WWTP, such as a loss of treatment capacity resulting in the passage of solids to downstream processes, must also be considered. To account for such events, a contingency operating plan must be developed for the operation of both the AWTF and WWTP. The potential impacts of a flow rate interruption on the management of downstream facilities from the AWTF are considered in Section 8.5.

The principal concerns include how to divert flow around the WWTP and AWTF and provide for the potential loss of ATW. For the WWTP an acceptable and usable discharge location is needed for off-spec treated effluent. The discharge point will vary depending on the duration of time in which the WWTP must be taken offline. If the flow rate being diverted to the AWTF is a relatively small portion of the total flow being treated, impacts will be minimal, and the flow may be recirculated. If a large percentage of the wastewater flow rate is being diverted to the AWTF, then a discharge location must be available or developed. Flows from the AWTF typically would be returned directly to the WWTP if the two plants are close-coupled or discharged to the local wastewater collection system. The use of water for nonpotable reuse applications may also be an option.

7.7 Alternative Technologies

Because DPR starts with a highly impaired source water (i.e., raw wastewater), it is important that the first few projects implemented in the United States are undertaken with deliberation, caution, and conservatism. As the knowledge base for existing and alternative new treatment

processes increases and experience from operational AWWTs is gained, it will be possible to make process changes in treatment and monitoring while still protecting public health.

In the future, it may be possible to achieve high-quality potable water for DPR applications with alternative technologies, the use of which will be necessary because many communities facing water shortages or extreme drought are also facing economic challenges. These communities will need the flexibility to implement alternative treatment technologies that cost less or use less energy. How new technologies (with limited industry experience) are used in an AWWT treatment train will be an important consideration with respect to overall treatment reliability.

7.8 References

- Baronti, C.; Curini, R.; D'Ascenzo, G.; DiCoricia, A.; Gentili, A.; Samper, R. Monitoring Natural and Synthetic Estrogens at Activated Sludge Sewage Treatment Plants and in a Receiving River Water. *Environ. Sci. Technol.* **2000**, *34* (24), 5059–5066.
- CCR. *Water Recycling Criteria*, Title 22, Division 4, Chapter 3, California Code of Regulations: Sacramento, CA, 2015.
[https://govt.westlaw.com/calregs/Browse/Home/California/CaliforniaCodeofRegulations?guid=IE8ADB4F0D4B911DE8879F88E8B0DAAAE&originationContext=documenttoc&transitionType=Default&contextData=\(sc.Default\)](https://govt.westlaw.com/calregs/Browse/Home/California/CaliforniaCodeofRegulations?guid=IE8ADB4F0D4B911DE8879F88E8B0DAAAE&originationContext=documenttoc&transitionType=Default&contextData=(sc.Default)) (accessed 9/3/2015)
- CDPH. *California Surface Water Treatment Rule Alternative Filtration Technology Summary*, California Department of Public Health: Sacramento, CA, August, 2011.
- CDPH. Groundwater Replenishment Reuse FINAL Regulations, California Department of Public Health: Sacramento, CA, June, 2014..
- Fontaine, N.; Salveson, A. *WateReuse Research Foundation Project 11-02: H₂O Engineering TORCs/O₃ Ozonation System Validation Report*. Final report submitted to the California Department of Public Health by Carollo Engineers: Walnut Creek, CA, February 2014a.
- Fontaine, N.; Salveson, A. *Testing Results of the Pasteurization Demonstration Unit at the Ventura WRF*. Prepared for the City of Ventura and the Pasteurization Technology Group by Carollo Engineers: Walnut Creek, CA, 2014b.
- Halliwell, D.; Burris, D.; Deere, D.; Leslie, G.; Rose, J.; Blackbeard, J. *Utilization of Hazard Analysis and Critical Control Points Approach for Evaluating Integrity of Treatment Barriers for Reuse*. Project Number WRRF-09-03, WateReuse Research Foundation: Alexandria, VA, 2014.
- Ishida, C.; Salveson, A.; Robinson, K.; Bowman, R.; Snyder, S. Ozone Disinfection with the HiPO_x Reactor: Streamlining an Old Technology for Water Reuse. *Water Sci. Technol.* **2008**, *58* (9), 1765–1773.
- Linden, K.; Salveson, A.; Thurston, J. *Innovative Treatment Technologies for Reclaimed Water*. Project Number WRRF-02-009, WateReuse Research Foundation: Alexandria, VA, 2012.

- Lovins, W.; Taylor, J.; Hong, S. Microorganism Rejection by Membrane Systems. *Environ. Eng. Sci.* **2002**, *19* (2), 453–465.
- NWRI. *Examining the Criteria for Direct Potable Reuse*. Independent Advisory Panel Final Report prepared for Trussell Technologies, Inc., under WateReuse Research Foundation Project No. 11-02, National Water Research Institute: Fountain Valley, CA, 2013.
<https://www.watereuse.org/product/11-02-1> (accessed 9/3/2015)
- Olivieri, A.; Seto, E.; Soller, J.; Crook, J. *Application of Microbial Risk Assessment Techniques to Estimate Risk Due to Exposure to Reclaimed Waters*. Project Number WRRF-04-011, WateReuse Research Foundation: Alexandria, VA, 2007.
- Pecson, B.; Trussell, R. S.; Pisarenko, A. N.; Trussell, R. R. Achieving Reliability in Potable Reuse: The Four Rs. *J. AWWA.* **2015**, *107* (3), 48–58.
- Regli, S.; Rose, J. B.; Haas, C. N.; Gerba, C. P. Modeling the Risk from *Giardia* and Viruses in Drinking Water. *J. AWWA.* **1991**, *83* (11), 76–84.
- Rose, J. B.; Farrah, S. R.; Harwood, V. J.; Levine, A. D.; Kukasik, J.; Menendez, P.; Scott, T. M. *Reduction of Pathogens, Indicator Bacteria, and Alternative Indicators by Wastewater Treatment and Reclamation Processes*. Report for Water Environment Research Foundation, Alexandria, VA, 2004.
- Salveson, A.; Brown, J.; Zhou, Z.; Lopez, J. *Monitoring for Microconstituents in an Advanced Wastewater Treatment Facility and Modeling Discharge of Reclaimed Water to Surface Canals for Indirect Potable Reuse*. Project Number WRRF-06-019, WateReuse Research Foundation: Alexandria, VA, 2010.
- Salveson, A.; Rauch-Williams, T.; Dickenson, E.; Drewes, J.; Drury, D.; McAvoy, D.; Snyder, S. *A Proposed Suite of Indicators for Assessing the Efficiency of Secondary Treatment for the Removal of Organic Trace Compounds*. Water Environment Research Foundation Project CEC4R08, Final Report. WateReuse Research Foundation: Alexandria, VA, 2012.
- Salveson, A.; Salveson, M.; Mackey, E.; Flynn, M. *Application of Risk Reduction Principles to Direct Potable Reuse*. WateReuse Research Foundation Project 11-10, Final Report. WateReuse Research Foundation: Alexandria, VA, 2014.
- Salveson, A.; Steinle-Darling, E.; Trussell, S.; Trussell, B.; McPherson, L. *Guidelines for Engineered Storage for Direct Potable Reuse*. Project Number WRRF-12-06, , WateReuse Research Foundation: Alexandria, VA, in press.
- Schäfer, A. I.; Fane, A. G.; Waite, T. D., eds.; *Nanofiltration, Principles and Applications*. Elsevier Ltd.: Oxford, UK, 2005.
- Sedlak, D. L.; Kavanaugh, M. *Removal and Destruction of NDMA and NDMA Precursors during Wastewater Treatment*. Project Number WRRF-01-002. WateReuse Research Foundation: Alexandria, VA, 2006.

- Snyder, S.; Korshin, G.; Gerrity, D.; Wert, E. *Use of UV and Fluorescence Spectra as Surrogate Measures for Contaminant Oxidation and Disinfection in the Ozone/H₂O₂ Advanced Oxidation Process*, Project Number WRRF-09-10, WateReuse Research Foundation: Alexandria, VA, 2012.
- Steinle-Darling, E. Water Quality Testing at the Raw Water Production Facility in Big Spring, Texas. WateReuse California Annual Conference, March 2015.
- Steinle-Darling, E.; Litwiller, E.; Reinhard, M. Effects of Sorption on the Rejection of Trace Organic Contaminants during Nanofiltration. *Environ. Sci. Technol.* **2010**, *44* (7), 2592–2598.
- Tchobanoglous, G.; Stensel, H. D.; Tsuchihashi, R.; Burton, F. L. *Wastewater Engineering: Treatment and Resource Recovery*, 5th ed. Metcalf & Eddy/AECOM, McGraw-Hill: New York, 2014.
- Trussell, R. R.; Salveson, A.; Snyder, S. A.; Trussell, R. S.; Gerrity, D.; Pecson, B. M. *Potable Reuse: State of the Science Report and Equivalency Criteria for Treatment Trains*. WateReuse Research Foundation: Alexandria, VA, 2013.
- Trussell, R. R.; Salveson, A.; Snyder, S. A.; Trussell, R. S.; Gerrity, D.; Pecson, B. M. *Equivalency of Advanced Treatment Trains for Potable Reuse*. Project Number WRRF-11-02. WateReuse Research Foundation: Alexandria, VA, 2015.
- U.S. EPA. Stage 1 Disinfectant and Disinfection Byproduct Rule, 63 CFR 69,390. *Federal Register*. U.S. Environmental Protection Agency: Washington, DC, 1998.
- U.S. EPA. *Guidance Manual for Compliance with the Filtration and Disinfection Requirements for Public Water Systems Using Surface Water Sources*. Office of Drinking Water. Prepared by Malcolm Pirnie, Inc. and HDR Engineering, Inc., under EPA Contract no. 68-01-6989, Washington, DC, 1990.
- U.S. EPA. *Surface Water Treatment Rule Guidance Manual*. EPA 68-01-6989, Cincinnati, OH, 1991.
- U.S. EPA. *LT1ESWTR Disinfection Profiling and Benchmarking Technical Guidance Manual*. EPA 816-R-03-004, Office of Drinking Water (4606M), U.S. Environmental Protection Agency: Washington, DC, 2003.
- U.S. EPA. *Comprehensive Surface Water Treatment Rules Quick Reference Guide: Systems Using Conventional or Direct Filtration*. EPA 816-F-04-003, Office of Water, U.S. Environmental Protection Agency: Washington, DC, 2004.
http://water.epa.gov/lawsregs/rulesregs/sdwa/mdbp/upload/2005_05_11_mdbp_qrg_mdbp_surfacewatertreatment_convent_direct.pdf (accessed 9/3/2015)
- U.S. EPA. Stage 2 Disinfectant and Disinfection Byproduct Rule 71 CFR 388. *Fed Regist*, January 4, 2006a.
- U.S. EPA. *Ultraviolet Disinfection Guidance Manual for the Final Long Term 2 Enhanced Surface Water Treatment Rule*. Office of Water (4601), EPA 815-R-06-007. U.S. Environmental Protection Agency: Washington, DC, 2006b.

U.S. EPA. LT2ESWTR National Primary Drinking Water Regulations: Long Term 2 Enhanced Surface Water Treatment Rule. Vol. 71, No. 3 CFR 654–786. *Fed Regist*, January 5, 2006c.

Walker, T.; Stanford, B. D.; Robillot, C.; Snyder, S.; Khan, S.; Vickers, J. *Critical Control Point Assessment to Quantify the Robustness and Reliability of Multiple Treatment Barriers of a DPR Scheme*. Project Number WRRF-13-03. WateReuse Research Foundation: Alexandria, VA, in press.

WRD. *Amended Title 22 Engineering Report for the Leo. J. Vander Lans Water Treatment Facility Expansion: Alamitos Barrier Recycled Water Project. Final Report*. Report prepared for the Water Replenishment District of Southern California by CDM Smith: Boston, MA, 2013.

Chapter 8

Management of Advanced Treated Water

Following the production of advanced treated water (ATW), as described in Chapter 7, the next step will depend on how this water is to be managed. Typically, ATW in a direct potable reuse (DPR) application would be introduced at the entrance of an existing drinking water treatment facility (D WTF) as a raw water supply. The effects of blending ATW with other raw water sources must be understood, including water quality, treatability, and corrosivity issues. In addition, potential flow interruptions and diurnal variations, if any, must also be considered. The subjects addressed in this chapter include:

- What potential water quality impacts can result from blending ATW with other raw water sources prior to D WTF?
- What log reduction credits for pathogen disinfection can be achieved through D WTF?
- What potential water quality impacts can result from flow interruptions and diurnal flow rate variations?
- What are the appropriate responses to deviations from performance specifications?

8.1 Blending of Advanced Treated Water with Other Source Waters before Drinking Water Treatment

Existing D WTFs may be impacted positively or negatively when ATW from an advanced water treatment facility (A WTF) is blended upstream of the D WTF. The impacts of blending two different types of ATW with surface water sources are examined in Sections 8.1.1 and 8.1.2.

8.1.1 Blending Advanced Treated Water from an Advanced Water Treatment Facility with Reverse Osmosis in the Treatment Train with Other Surface Water Sources

The potential effects of blending surface water with ATW produced from an A WTF employing ultrafiltration (UF), reverse osmosis (RO), and ultraviolet (UV) disinfection combined with advanced oxidation process (AOP) (referred to as UF/RO/UV-AOP) in the treatment train are identified in Table 8.1. For example, blending adversely affects the existing coagulation process by: (1) reducing the alkalinity to a point where additional alkalinity must be supplemented to promote coagulation; or (2) decreasing turbidity, which minimizes particle removal, thereby making conventional treatment performance more difficult to monitor and maintain because turbidity removal may be low throughout the various treatment processes. The potential increase in temperature of the blended water could also affect treatment kinetics, odor production, and aesthetic acceptance. The specific effects will vary with the blending ratio and chemical characteristics of the waters to be blended. The impacts would be similar for groundwater under the influence of surface water (GWUDI) that would have to be treated. The water quality impacts of blending different types of waters are considered in Peet et al. (2001) and Taylor et al. (2005).

Table 8.1. Potential Water Quality Impacts from Blending Two Different Types of ATW (UF/RO/UV-AOP and O₃/BAF/UF) with Other Untreated Surface Water Upstream of a DWTF

Issue	Potential Impacts ^a	
	UF/RO/UV-AOP	O ₃ /BAF/UF
Organic material	Contribution of ATW will decrease organic content of resulting blend, which may result in improvements in efficiency of conventional water treatment. Decreasing turbidity minimizes particle removal, making conventional treatment performance more difficult to monitor and maintain because turbidity removal may be low throughout various treatment processes.	Depending on efficiency of wastewater treatment process and type of surface water, ATW could increase or decrease organic content of resulting blend.
Inorganics	Natural occurring minerals (i.e., TDS) and metal concentrations will be reduced. Alkalinity may be reduced to a point where additional alkalinity must be supplemented to promote coagulation.	Naturally occurring minerals (i.e., TDS) and metal concentrations might be increased in the blended water.
Nutrients	ATW may reduce the concentration of nutrients, depending on the nature of the surface water.	The ATW may increase the concentration of nutrients, depending on the degree of wastewater treatment and nature of the surface water.
Trace-level constituents (e.g., CECs, TOrCs)	ATW may reduce concentration and composition of trace chemical constituents in surface water.	ATW may increase concentration and composition of some trace chemical constituents while diluting most others.
Disinfectant stability and DBPs	ATW is likely to provide a more stable disinfectant residual and decrease TTHM and HAAs formation.	Because of different precursors being introduced and depending upon efficiency of advanced treatment process and TOC, disinfectant residuals may be less stable and DBPs (e.g., TTHM and HAA5) may form in greater or lesser concentrations and different compositions.
Corrosion and chemical stability ^b	Depending on blending ratio, potential corrosiveness of ATW will be decreased by increase in pH, TDS, hardness, and alkalinity after blending.	Depending on blending ratio, potential corrosiveness of blended water will stay the same or decrease.
Temperature	In general, temperature of blended water will increase, which may affect water treatment process kinetics and temperature of final treated drinking water. Increased water temperature, in general, improves treatment performance, but may create an aesthetic concern depending upon temperature of existing water supplies.	
Aesthetics	Adding ATW may improve aesthetic characteristics of blended water. An increase in temperature may impact aesthetic acceptance.	
Pathogens	Concentrations of pathogens would most likely be reduced in the blended water.	

Notes:^a Potential impacts depend on the blending ratio (i.e., the ratio of the volume of ATW and the volume of other untreated source waters) and composition of the ATW and other source waters. ^b When assessing the water quality resulting from blending, mass balance calculations may apply for some of the parameters responsible for corrosion and chemical stability; however, the complexity of the corrosion phenomenon warrants that each water blend should be examined individually (Tang et al., 2006). AOP=advanced oxidation process; ATW=advanced treated water; BAF=biologically active filtration; CEC=constituent of emerging concern; DBP=disinfection byproduct; DWTF=drinking water treatment facility; HAA=haloacetic acid; RO=reverse osmosis; TDS=total dissolved solids; TOC=total organic carbon; TOrC=trace organic compounds; TTHM=total trihalomethanes; UF=ultrafiltration; UV=ultraviolet.

8.1.2 Blending Advanced Treated Water from an Advanced Water Treatment Facility without Reverse Osmosis in the Treatment Train with Other Surface Water Sources

The potential effects of blending surface water with ATW produced from an AWTF employing ozone (O₃) with biologically active filtration (BAF) and UF (referred to as O₃/BAF/UF) in the treatment train are identified in Table 8.1. The ATW could increase the organic content of the blended water, which could affect the DWTF treatment process. As noted in Section 8.1.1, specific effects will vary based on the blending ratio and chemical characteristics of the waters to be blended. Also, the impacts for treated GWUDI could be similar to those reported in Table 8.1, depending on the relative amount of each source water.

8.1.3 The Need for Bench-Scale Testing before Initiating Blending Operations

The potential impacts associated with blending ATW with other waters treated at the DWTF must be considered when developing a DPR program design. Impacts are likely to be site specific; consequently, bench- and pilot-scale testing before blending ATW with other raw water sources ahead of a DWTF is a necessary step in planning any DPR project. Some tests that can be used to guide the blending strategy are summarized in Table 8.2.

Table 8.2. Suggested Tests to Guide the Blending Strategy

Concern	Potential Tests
Treatability	Jar tests; bench- and pilot-scale plant treatability tests
Corrosion control	Bench-top studies, pipe loop testing
Disinfection byproduct control	Formation potential tests in conjunction with treatability studies
Temperature	Jar tests, precipitation tests, filter column studies, reaction kinetic studies

8.2 Microbial Log Reduction Credits for Surface Water Treatment

The goal of any drinking water treatment process sequence is the aggregate reduction of pathogens from source water to levels below the detection limit. The log reduction credits assigned to each unit treatment process (i.e., treatment barrier) are intended to ensure the microbial quality of the water with a sufficient margin of safety in the event of some malfunction of any individual unit process. The federal log reduction requirements for surface water treatment and their applications to ATW are considered in Sections 8.2.1 and 8.2.2.

8.2.1 Log Reduction Requirements

The general conventional federal log reduction requirements for drinking water treatment of surface waters are 6-log reduction for coliform bacteria, 4-log reduction for virus, and 3-log reduction *Giardia* removal. The Long Term 2 Enhanced Surface Water Treatment Rule

(LT2ESWTR) sets criteria to determine the required *Cryptosporidium* log reduction credit between 2 and 5.5 logs, based upon the *Cryptosporidium* status of the raw surface water or GWUDI source from measurements over a 12 to 24 month period (see Chapter 4). ATW as a raw water entering a DWTF would be subject to the LT2ESWTR assessment paradigm (i.e., the design of the DWTF would be based on the observed level of *Cryptosporidium* oocysts in the blended water entering the DWTF). The presence of advanced water treatment prior to the DWTF would not eliminate the requirements from Subpart H of the LT2ESWTR for *Giardia* and viruses, including disinfection.

8.2.2 Impact of Advanced Treated Water on Log Reduction Requirements

If ATW from an AWTF is introduced into a DWTF, it is unlikely to have measurable *Cryptosporidium* oocysts. If this is the case, then the addition of ATW to the DWTF influent water would have no impact on the DWTF's LT2ESWTR bin placement and, therefore, would not require additional treatment beyond conventional processes.⁸

8.3 Blending Finished Water with Other Drinking Water

In the future, if finished water (see Chapter 2) is introduced (1) directly into a drinking water distribution system containing treated chlorinated surface water or treated/untreated groundwater (which may or may not be chlorinated) or (2) into a separate distribution system, a number of factors must be considered, including:

- Where and how will the finished water be introduced into the drinking water distribution system?
- What post-advanced water treatment quality requirements are needed to protect the potable distribution system infrastructure and minimize water quality impacts, especially corrosion effects?

These questions must be resolved before finished water can be introduced directly into the drinking water distribution system.

8.4 Process Control for Deviations from Performance Specifications

In the event of a significant deviation from a performance specification potentially affecting the safety of the ATW, a decision must be made on appropriate actions to protect public health. Much like the judgments required in the event of a violation of a drinking water standard in a DWTF, decisions must be made relative to water treatment adjustments in an AWTF. Options should be available to divert the ATW from the DWTF. For example, when the DWTF experiences operational challenges, an opportunity exists to take a number of mitigation steps prior to treatment failure, including the following:

⁸Note that current U.S. EPA guidance for existing surface water treatment plants is such that once treatment is installed to address risk from *Cryptosporidium* under LT2ESWTR, reducing that level of treatment is unlikely; therefore, the dilution of existing source water with ATW is unlikely to lead to a reduction in minimum treatment at an existing DWTF.

- Failsafe automatic shutdown protocols
- Process set points that trigger investigation and remediation
- Process startup and shutdown protocols that waste potentially off-spec water
- Automated process adjustments for flow, chemical demand, and energy requirements (e.g., UV)
- Operating rules that transition between process trains prior to unit process failure (e.g., granular activated carbon, filters, or ion exchange)
- Transition to backup water supply sources

The robustness of drinking water systems lies in their operation within a reliable performance envelope that has a margin of safety for when the treatment train is stressed by conditions beyond its control. For DPR to be implemented effectively, the entire system should be coordinated closely so that individual unit processes are not operated on the edge of their performance envelope. Similar protocols will be needed for the management of the WWTP and AWTF. When performance degradation reaches unacceptable levels, shutting down the DWTF is seldom a viable option [under the Safe Drinking Water Act (SDWA), there are processes for public notification]. This last step would not be relevant to a WWTP, AWTF, or engineered storage buffer (ESB) operation in a DPR program, but there is a need for shutdown and re-start protocols for flow from each of these barriers in the DPR system prior to returning to the use of ATW from the AWTF.

8.5 Process Control for Flow Interruptions and Diurnal Flow Variations

In addition to the water quality deviations discussed in Section 8.4, provisions must be made to address impacts that can result from potential ATW flow interruptions and diurnal flow variations.

8.5.1 Flow Interruptions

As noted in Chapter 7, it may be necessary to take the AWTF offline for some period of time if there is breakthrough of specific constituents or a catastrophic process failure. The potential impact of a flow interruption on the management of ATW will depend on:

- Duration of the interruption
- Relative quantities of water involved
- Availability of alternative water sources
- Ability to switch to alternative sources

For flow interruption of short duration with a relatively large volumetric mixing ratio (i.e., a relatively small proportion of ATW is in the mix), the impacts, if any, will be minimal in most cases. If the duration of the interruption is on the order of a day, additional storage or discharge points may be necessary beyond that provided by the ESB as described in Chapter 7, again depending on the volumetric mixing ratio. If the flow is interrupted for days, alternative water sources may have to be brought online. For ATW, the operational concern with a long flow interruption is the ability to switch the operation of a DWTF to process source water with different water quality characteristics. For finished water, the concern is with changing the chemistry in the distribution system. Although the analysis of what should

be done in the case of a flow interruption will be site specific, it is imperative that a contingency plan is developed for changing source waters and ensuring that alternative water sources will be available.

8.5.2 Diurnal Flow Variations

Depending on the size of the facility, the potential impact of the diurnal flow variation must be considered. In locations where wastewater flow is insufficient during the evening and early morning hours, the AWTF will be subject to diurnal flow variations, which can have significant process and equipment impacts. For example, at one AWTF stress cracks developed in the welds on the MF membrane outlet piping caused by the cycling from diurnal flow variation. In an ideal scenario, the flow to the AWTF would be equalized; however, in small decentralized plants operated at a constant flow rate, equalization generally will not be a concern.

8.6 References

- Peet, J. R.; Kippin, S. J.; Marshall, J. S.; Marshall, J. M. *Water Quality Impacts from Blending Multiple Water Types*. Water Research Foundation and American Water Works Association, Denver, CO, 2001.
- Tang, Z.; Hong, S.; Xiao, W.; Taylor, J. Characteristics of Iron Corrosion Scales Established Under Blending of Ground, Surface, and Saline Waters and Their Impacts on Iron Release in the Pipe Distribution System. *Corros. Sci.* **2006**, *48*, 322–342.
- Taylor, J. S.; Dietz, J. D.; Randall, A. A.; Hong, S. K.; Norris, C. D.; Mulford, L. A.; Arevalo, J. M.; Imran, S.; Le Puil, M.; Liu, S.; Mutoti, I.; Tang, J.; Xiao, W.; Cullen, C.; Heaviside, R.; Metha, A.; Patel, P.; Vasquez, F.; Webb, D. *Effects of Blending on Distribution System Water Quality*. Water Research Foundation and Tampa Bay Water: Denver, CO, 2005.

Chapter 9

Process Monitoring

An advanced water treatment facility (AWTF) for DPR must incorporate a robust and comprehensive monitoring and control system that can be used to measure and record the performance of each treatment process to determine if the ATW meets performance specifications and, therefore is protective of public health. Process monitoring for DPR systems involves the ability to: (1) accurately measure treatment performance using the control system; (2) monitor system performance in accordance with design intent and manufacturer's recommendations; and (3) react and respond in a proactive manner. Adopting process control and monitoring targets ensures that the treatment system is reliably meeting performance goals and producing water that is protective of public health. The following subjects are discussed in this chapter:

- What are the strategies for process monitoring and control?
- What pathogen removal credits are allocated for various process monitoring and control strategies?
- What are the strategies for maximum contaminant levels (MCLs), secondary MCLs, and constituents of emerging concern (CECs)?
- What constitutes startup/documentation of baseline performance?
- What are the elements of long-term performance monitoring?

9.1 Overview of Process Monitoring

Acute risks (e.g., exposure to pathogens) and chronic risks (e.g., exposure to chemicals) must be considered when evaluating risk and developing strategies for process monitoring and control. It will be necessary to anticipate and prevent deterioration in process performance, as well as detect and respond to process upsets. The recommended process monitoring and control strategies presented in this chapter are intended to address both acute and chronic health risks through water quality analysis, encompassing a wide range of microbial and chemical constituents. System monitoring for pathogens and chemical constituents are considered in Sections 9.2 and 9.3, respectively. Control strategies are considered in Chapters 8 and 11.

9.2 Monitoring for Pathogens

The pathogen monitoring method employed for a particular treatment process can be used to:

- Predict pathogen removal performance [e.g., calibrated ultraviolet (UV) sensors for UV disinfection]. Estimate pathogen removal performance [e.g., the use of pressure decay tests (PDTs) for ultrafiltration (UF) monitoring]
- Serve as a parameter for evaluating relative changes in process performance (e.g., turbidity), although it cannot be used to directly predict performance

Online real-time monitoring techniques (e.g., disinfectant residuals) are recommended whenever feasible, especially those that relate directly or indirectly to microbial removal performance.

9.2.1 Pathogen Control for Direct Potable Reuse

The pathogen monitoring and control approach based on critical control points (CCPs) was introduced in Chapter 7. In the AWTF treatment train shown in Figure 9.1, secondary effluent is treated further with microfiltration (MF) or UF, reverse osmosis (RO), and UV-advanced oxidation (UV-AOP), followed by an engineered storage buffer (ESB) with free chlorine disinfection. For each treatment process, the goal is to establish a CCP used to assess—based on measured data—whether the unit treatment process is functioning as expected or has been compromised.

9.2.2 Example of Pathogen Critical Control Points for Direct Potable Reuse

The application of the CCP approach to determine log reduction credits for pathogens for the example AWTF treatment train shown in Figure 9.1 is illustrated in Table 9.1. In the future, it may be possible to develop a CCP for secondary treatment based on some of the analytical techniques currently under development.

9.3 Monitoring for Chemical Constituents

Because of the advanced treatment technologies used, the ATW from an AWTF typically will meet most safe drinking water standards before passing through a DWTF; however, the ATW may also need to meet specified limits for other constituents (such as CECs), depending on local or state regulations.

9.3.1 Chemical Constituent Control for Direct Potable Reuse

Municipalities, utilities, and agencies should assess CECs for their specific regions. An initial list of CECs can be developed based on the work of an Independent Advisory Panel (IAP) convened by the National Water Research Institute (NWRI) for WateReuse Research Foundation (WRRF) Project 11-02 (NWRI, 2013). A list of recommended CECs was developed by the IAP to be considered in DPR projects (see Appendix C).

9.3.2 Example of Chemical Constituent Control for Direct Potable Reuse

Similar to pathogen monitoring, CCPs must be established for chemical constituents for each treatment process to assess—based on measured data—whether the unit treatment process is functioning as expected or has been compromised. Monitoring for chemical constituents is considered in Sections 9.4 (during facility startup) and 9.5 (long-term monitoring).

9.4 Process Monitoring during Startup and Documentation of Baseline Performance

Bringing an AWTF online involves a number of activities, including facility startup, commissioning and acceptance, and initial operator training. Water quality monitoring and the development of baseline performance data are also integral activities during facility startup, commissioning, and acceptance.

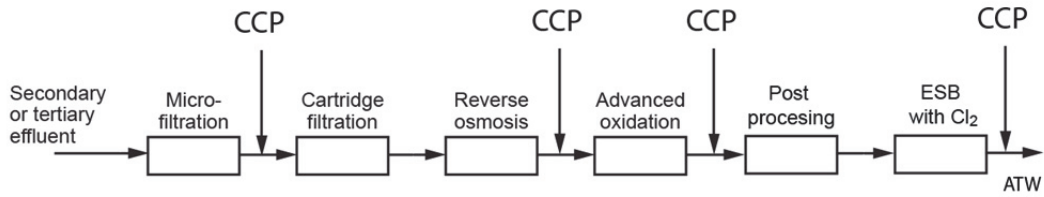

Figure 9.1. Typical AWTf process flow diagram with critical control points identified for the individual treatment processes for both process control and establishing log reduction credits.

Table 9.1. Pathogen Log Reduction Credits Based on the Example Monitoring Scheme Shown in Figure 9.1

Process	Critical Control Point Monitoring	Log Reduction Credits			Notes
		V	G	C	
Secondary treatment	None sufficiently proven	0	0	0	No clear correlation between rapid water quality measurements of secondary effluent and log reduction of pathogens. Site-specific performance information should be generated.
MF or UF	Daily PDT	0 ^a	4.0	4.0	PDT should be done daily to verify proper performance.
RO	Online EC	1.5	1.5	1.5	EC-monitored influent and effluent to the RO. Log reduction in system control must be based upon measured values.
UV-AOP	Intensity sensors	6	6	6	UV sensors should be calibrated per U.S. EPA (2006).
ESB with free chlorine, Cl ₂ , residual (≥0.4 mg/L)	Online Cl ₂	6	3	0	Size of ESB is dictated by FRT of UF system, which is the interval between UF membrane integrity tests (about 24 hours). System control is based on maintaining a minimum free residual of 0.4 mg/L over 24 hour storage time.
Total		13.5	14.5	11.5	

Notes: V=virus, G=*Giardia*, and C=*Cryptosporidium*; ^a 0=virus credit could be awarded on a case-by-case basis for UF; AOP=advanced oxidation process; EC=electrical conductivity; ESB=engineered storage buffer; FRT=failure response time; MF=microfiltration; PDT=pressure decay testing; RO=reverse osmosis; UF=ultrafiltration; UV=ultraviolet.

9.4.1 Monitoring during Initial Startup

At startup (and prior to system operation), water quality monitoring is needed for each treatment process and final product water quality. In most startup plans, the typical initial startup period is 30 days, although the duration of commissioning and acceptance testing may take up to 6 months (see Chapter 11). The types of data collected during the startup period are identified in Table 9.2.

9.4.2 Documentation of Baseline Performance

The water quality monitoring data obtained during startup is intended to document and verify that system performance meets specifications and the ATW is protective of public health. The data also serve as a baseline of system performance for future comparison and analysis.

9.5 Long-Term Performance Monitoring

The objective of long-term performance monitoring of a DPR system is to demonstrate the continuous production of high-quality water. This objective is accomplished through online monitoring that is supported by frequent (but limited) grab samples, as well as a more periodic comprehensive grab sampling program.

Table 9.2. Example Startup Testing for the AWTF Flow Diagram Shown in Figure 9.1

Process	Test	Sample		Notes
		Type	Frequency	
Secondary effluent	Effluent turbidity, BOD, and TSS microbial indicators	Online and grab	Online (continuous) and grab (daily) for 30 days	Sets baseline water quality.
	Effluent MCLs, secondary MCLs, and health advisory values ^a	Grab	2 samples over 30 days	Provides a preliminary understanding of trace constituents ahead of advanced treatment.
MF or UF	PDT	Offline testing	Daily	None.
RO	Influent and effluent TOC	Online and grab	Online (continuous) and grab (daily) for 30 days	TOC reduction to <0.5 mg/L is expected with well-functioning RO membranes.
	Influent and effluent EC	Online and grab	Online (continuous) and grab (daily) for 30 days	EC monitoring is required for long-term operation.
	Influent and effluent CECs ^b	Grab	2 samples over 30 days	Demonstrates removal by key process for CEC reduction (RO).
UV-AOP	Influent and effluent NDMA and 1,4-dioxane (if	Grab	2 samples over 30 days	Demonstrates UV and oxidant doses and removal of indicator

Process	Test	Sample		Notes
		Type	Frequency	
	present in source water)			constituents difficult to remove by other techniques. 1,4-dioxane is primarily removed by AOP; NDMA by UV photolysis.
	UV sensors	Online and verification	Online (continuous) and verification (weekly) monitoring	Comparisons to anticipated values from manufacturers required.
	Influent UVT	Online and grab	Online (continuous) and grab (daily) monitoring	None.
	Effluent <i>E. coli</i> and total coliform	Grab	Weekly for 1 month	Total coliform is not an MCL, but rather a general bacteria performance check.
	Effluent MCLs, secondary MCLs, health advisory values, CECs ^{a,b}	Grab	2 samples over 30 days	Demonstrates quality of ATW ahead of blending.
	Influent and effluent chloramine	Grab	Daily for 30 days	UV-AOP performance correlates with chloramine destruction.
ESB with free chlorination	Effluent free chlorine residual	Online and grab	Online (continuous) and grab (daily) for 30 days	Demonstrates the ability to maintain minimum target residual and minimum CT.

Notes: ^aRecommended MCL and secondary MCL values are given in Appendix G. ^bCECs are defined in Table 7.5. AOP=advanced oxidation process; ATW=advanced treated water; BOD=biochemical oxygen demand; CEC=constituent of emerging concern; CT=chlorine residual, C, multiplied by time, T; EC=electrical conductivity; ESB=engineered storage buffer; MCL=maximum contaminant load; NDMA=N-nitrosodimethylamine; PDT=pressure decay testing; RO=reverse osmosis; TOC=total organic carbon; TSS=total suspended solids; UV=ultraviolet.; UVT=UV transmittance.

9.5.1 Online and Calibration Sampling

Continuous online sampling and periodic bench-top calibration of online meters are needed; possible sampling and frequencies are summarized in Table 9.3. Staff at the AWTF should perform all bench-top testing.

9.5.2 Periodic Sampling

Periodic sampling is conducted to verify process performance, as well as to verify and calibrate field monitors. Potential long-term periodic grab sampling for water quality monitoring is summarized in Table 9.4.

9.5.3 Annual Reporting

The preparation of an annual report is an integral part of the monitoring process for an AWTF. Annual reports, as discussed in Chapter 11, typically are prepared for three reasons: (1) fulfill the requirements of the permit to operate, as specified by the regulatory agency; (2) provide an in-depth review and critical evaluation of facility operation in meeting the stated water quality objectives; and (3) maintain a historical record of facility operation.

The reporting of water quality data is documented in Section 11.6.3, including an example of the topics on AWTF performance addressed in the annual report.

9.6 Special Studies

Special studies often are undertaken to test improved or new technologies and resolve specific treatment issues. When planning for an AWTF, a small budget should be allocated to conduct special studies as needed.

9.6.1 Testing of Improved and New Technologies

Improvements to existing technologies, as well as the development of new technologies, are continuous processes. Most agencies that operate AWTFs have an active program to evaluate improved and new technologies. For example, the Orange County Water District routinely conducts side-by-side tests of new or improved RO membranes. Testing is accomplished by running a single module containing an improved or new membrane in parallel with a bank of existing membranes. In this manner valid performance comparisons can be made because the test module and existing modules receive the same input water for treatment. New technologies are similarly pilot-tested in parallel with existing technologies or processes.

9.6.2 Process Performance and Control Issues

Special studies often are undertaken to test new chemicals, identify reasons for observed reductions in process performance, test new operating procedures, or improve process performance. For example, new chemicals are being developed continually to limit RO membrane fouling, and some of these new chemicals may be useful in improving pathogen performance monitoring (e.g., fluorescent dyes).

Table 9.3. Example Long-Term Online and Calibration Sampling for the Flow Diagram Shown in Figure 9.1

Process	Test	Sample Type	Frequency of Sampling during Operation
Secondary effluent	Turbidity and microbial indicators	Online and grab	Turbidity: online (continuous) and grab (weekly); microbial: grab (weekly)
	Ammonia, TSS, and BOD	Grab	Weekly
MF or UF	PDT	Offline testing	Daily
	Turbidity	Online and grab	Online (continuous) and grab (weekly)
RO	Influent and effluent EC and TOC	Online and grab	Online (continuous) and grab (weekly)
UV-AOP	UV sensors	Online and grab	Online (continuous) and verification (weekly)
	Influent UVT	Online and grab	Online (continuous) and grab (weekly)
	Influent and effluent chloramine	Online and grab	Online (continuous) and grab (weekly)
ESB with free chlorination	Effluent free chlorine residual	Online and grab	Online (continuous) and grab (weekly)

Notes: AOP=advanced oxidation process; BOD=biochemical oxygen demand; EC=electrical conductivity; ESB=engineered storage buffer; MF=microfiltration; PDT=pressure decay testing; RO=reverse osmosis; TOC=total organic carbon; TSS=total suspended solids; UF=ultrafiltration; UV=ultraviolet; UVT=UV transmittance.

Table 9.4. Long-Term Periodic Sampling (All Grab Samples)

Monitoring Parameters	Sample Locations ^a	Regulatory Monitoring	Process Monitoring	Frequency
TOC, EC	ROF, ROP		✓	Monthly
MCLs, secondary MCLs ^b , and health advisory values	ATW	✓		Quarterly or as mandated by state
CECs ^c	UV-AOP		✓	Quarterly (initially)
Total coliform, <i>E. coli</i>	UV-AOP	✓		As mandated by state
NDMA	UV-AOP		✓	Quarterly

Notes: ^aROF=RO feed, ROP=RO permeate, UV-AOP=UV-AOP effluent. ^bMCL and secondary MCL values are shown in Appendix G. ^cSome typical CECs are identified in Table 7.5. AOP=advanced oxidation process; ATW=advanced treated water; CEC=constituent of concern; EC=electrical conductivity; MCL=maximum contaminant load; NDMA=N-nitrosodimethylamine; RO=reverse osmosis; TOC=total organic carbon; UV=ultraviolet.

9.7 References

- NWRI. *Examining the Criteria for Direct Potable Reuse*. Independent Advisory Panel Final Report prepared for Trussell Technologies, Inc., under WateReuse Research Foundation Project No. 11-02, National Water Research Institute: Fountain Valley, CA, 2013.
<https://www.watereuse.org/product/11-02-1> (accessed 9/3/2015)
- Salveson, A.; Salveson, M.; Mackey, E.; Flynn, M. *Application of Risk Reduction Principles to Direct Potable Reuse*. Project Number WRRF-11-10. WateReuse Research Foundation: Alexandria, VA, 2014.
- U.S. EPA. *Ultraviolet Disinfection Guidance Manual for the Final Long Term 2 Enhanced Surface Water Treatment Rule*; EPA 815-R-06-007. Office of Water, U.S. Environmental Protection Agency: Cincinnati, OH, 2006.

Chapter 10

Residuals Management

Residuals are the materials generated from the treatment processes used to produce advanced treated water (ATW) at an advanced water treatment facility (AWTF). The types of residuals produced will depend on the specific technologies employed in the treatment train. Managing these residuals will involve the planning, design, and operation of facilities to reuse or dispose of residuals from the AWTF. Factors to consider when developing a residuals management strategy include:

- What types of residuals result from an AWTF producing ATW?
- What management options are available for residuals from an AWTF, with the exception of reverse osmosis (RO) concentrate?
- What management options are available for RO concentrate?
- What are the regulatory concerns with the management of residuals and RO concentrate from an AWTF?
- What is the cost of RO concentrate management?

10.1 What Residuals Result from an Advanced Water Treatment Facility?

The residuals resulting from an AWTF producing ATW from treated wastewater effluent will depend on the combination of processes employed for treatment. Typical residuals can include:

- Screenings from prescreening facilities
- Backwash solids from biologically active carbon filters
- Periodic backwash stream from the microfiltration (MF) or ultrafiltration (UF) process
- Backwash solids from the cartridge filters
- RO concentrate, where RO is used in the process

The residuals resulting from an AWTF producing finished water from treated wastewater effluent will be similar to those described previously, but may also include residuals from the water treatment process. At present, it is difficult to predict what additional treatment processes will be required, if any, for an AWTF that is also permitted as a drinking water treatment facility (DWTF).

10.2 Management of Non-RO Concentrate Residuals

The management of non-RO concentrate residuals is considered separately from the management of RO concentrate because these management methods differ significantly. The disposal of filter screenings, reject streams, and backwash water is considered in Section 10.2.1. The management of RO concentrate is considered in Section 10.2.2.

10.2.1 Filter Screenings

The most common methods of managing screenings (Tchobanoglous et al., 2014) include:

- Removal by hauling to disposal areas (i.e., landfills), including co-disposal with municipal solid wastes
- Incineration either alone or in combination with sludge and grit (for large installations only)
- Mixing and processing with thickened process solids
- Discharge to grinders or macerators, where the screenings are ground and returned to the wastewater

10.2.2 Reject Streams and Backwash Water

Where the AWTF is located near the wastewater treatment plant (WWTP), reject streams and backwash water are returned directly to the WWTP. Reject streams are often recycled to the inlet of the AWTF for reprocessing. Where the AWTF is located some distance away from the WWTP, these liquid streams are discharged to the wastewater collection system.

10.3 Management of RO Concentrate

Where RO is to be used for the production of ATW, the management of the RO concentrate is a major consideration, especially for inland locations. RO concentrate treatment and disposal options are considered in Sections 10.3.1 and 10.3.2, respectively.

10.3.1 RO Concentrate Treatment Options

Currently, a variety of treatment processes are available, and many others are under development, to reduce the volume of RO concentrate that must be managed. Processes used for RO concentrate minimization are summarized in Table 10.1. In some applications, treatment processes have been used in conjunction with other processes for the recovery of specific constituents. Most of the technologies listed in Table 10.1 have been applied to the concentration of brine solutions, but less experience is available in their application for the processing of RO concentrate containing organic matter. The application of the technologies listed in Table 10.1 usually is site specific and will depend on the volume and constituent concentration of the RO concentrate. Additional details on these technologies may be found in Cath et al. (2006), Mickley (2005, 2007a, 2007b, 2009), Sethi et al. (2006), and Voutchkov (2013).

10.3.2 RO Concentrate Disposal Options

The principal RO concentrate disposal options currently in use are described in Table 10.2. For coastal and near-coastal locations, ocean disposal through deep water outfalls is the method used. For inland locations without access to an ocean disposal, the first five options listed in Table 10.2, arranged in order of use, comprise 99% of the disposal options applied currently. For inland desalting operations of a scale sufficient to serve as part of a very small community water system (i.e., systems serving 25 to 500 people), deep well injection is often the only potentially feasible RO concentrate management option.

In some cases, RO concentrate from an inland location can be hauled for discharge into a wastewater collection system with sufficient dilution capacity. Furthermore, because of the cost of RO concentrate disposal for inland locations with small amounts of brine, regional solutions may be a feasible alternative (Raucher and Tchobanoglous, 2014). Nontraditional uses of concentrate are considered in Jordahl (2006).

Table 10.1. Summary of RO Concentrate Processing Options

Treatment Option	Status	Application
Crystallizers	P	Used to concentrate a brine stream into a crystalized form for processing (e.g., mineral recovery) or disposal.
Evaporation/ crystallization	P	Involves the combination of an evaporation unit to thicken the concentrate and a crystallizer to produce a semisolid material for disposal.
Falling film evaporators	P	Used with and without vapor compression to thicken the concentrate.
Forward osmosis	L	Natural osmotic pressure is used to thicken the concentrate. Water is removed from the concentrate stream using a concentrated draw solution. As water is withdrawn, the brine solution becomes more concentrated.
Membrane distillation	L	Involves the use of a porous, hydrophobic membrane to extract water vapor generated from a concentrated RO concentrate stream.
Multistage RO	P	Three stages are typically used to further concentrate the RO concentrate stream. The permeate from each stage is returned to the treatment process.
Solar evaporators	P	Where climatic conditions are favorable, solar evaporation can recover water and thicken the concentrate stream. The principal drawback of solar drying is the need for a large surface area.
Spray dryers	P	When used in place of crystallizers, spray dryers employ a vertical drying chamber to produce air with dry particles, which subsequently are removed with a bag filter.
Mechanical vapor compression evaporators	P	Brine is compressed mechanically. The resulting pressurized vapor is used to heat the RO concentrate. The condensed vapor (i.e., steam) becomes the distillate product.

Notes: L=new technology with limited full-scale applications with RO concentrate; P=proven technology, but with limited application in the processing of RO concentrate containing organic material; RO=reverse osmosis.

Source: Adapted in part from Raucher and Tchobanoglous (2014).

Table 10.2. Summary of RO Concentrate Disposal Options

Disposal Option	Use/Description
Surface water discharge	A common method of disposal is discharge of RO concentrate to surface waters, including lakes, reservoirs, or rivers, where sufficient dilution capacity is available. Membrane concentrate disposal in surface waters is regulated by the Clean Water Act and requires a permit under the National Pollutant Discharge Elimination System.
Discharge to the wastewater collection system	Suitable for relatively small discharges in which the increase in total dissolved solids is not significant [e.g., typically <20 to 50 milligrams per liter (mg/L)] and that otherwise comply with sewer ordinance local discharge limits.
Deep well injection	Depends on availability of a geologically suitable subsurface aquifer that is brackish or otherwise unsuitable for domestic uses.
Evaporation ponds (with or without a greenhouse)	Involves discharge of RO concentrate to shallow, lined ponds. A large surface area is required in most regions, with the exception of some southern and western states. Required surface area can be reduced using greenhouses. Solidified constituents typically are disposed of in hazardous waste landfills.
Land application	Used for some low-concentration RO concentrate solutions, though this option generally is not available. Some RO concentrate solutions can be disposed of in hazardous waste landfills.
Zero liquid discharge	Involves use of evaporators (e.g., vapor compression), brine concentrators, and crystallizers or spray dryers to convert RO concentrate to brine, a semisolid product, or a dry product suitable for landfill disposal. The recovery of useful salts may also be possible.
RO concentrate discharged through an existing effluent ocean outfall	In many locations, it is possible to discharge RO concentrate into an existing wastewater effluent ocean outfall.
RO concentrate discharged through a separate ocean outfall	The disposal option of choice for facilities located in coastal regions of the United States is an RO concentrate line with a deep water ocean discharge. Combined discharge with power plant cooling water has been used in Florida. For inland locations, trucks, rail hauling, or pipelines are needed for transportation.

Note: RO=reverse osmosis.

Source: Adapted in part from Raucher and Tchobanoglous (2014) and Mickley (2009).

10.4 Regulatory Concerns with the Management of Non-RO Residuals

In general, little regulatory concern exists with screenings, reject streams, backwash water, and any other non-RO concentrate residuals. As noted in Section 10.2.1, screenings are handled with other WWTP sludge. Reject streams and backwash water are returned to the wastewater treatment process or AWTF for further processing.

10.5 Regulatory Concerns with the Management of RO Concentrate

The principal constituents in RO concentrate are present in processed wastewater, but at a higher concentration. In addition, RO concentrate can contain small amounts of chemical additives used as antiscalants, disinfectants used to control bacterial fouling (e.g., chlorine), and the compounds in solutions used periodically to clean membranes. Regulatory issues related to the disposal of RO concentrate include toxicity, hazardous wastes, and radionuclides (SCSC and NWRI, 2014).

10.5.1 Toxicity

In general, toxicity to aquatic organisms is the principal concern where RO concentrate is discharged to surface waters and ocean environments. Toxicity can arise from specific constituents or combinations of constituents in the RO concentrate (e.g., organic constituents targeted for removal, such as pesticides) or common ions such as ammonium, calcium, potassium, and arsenic. Toxicity from common ions, with the exception of ammonium, generally is not an issue because of the initial dilution provided by the receiving water body and high background concentrations in discharges to estuarine and marine water bodies (Mickley, 2009). The extent of toxicity in commingled RO concentrate and receiving waters cannot be predicted in advance. Concentrate toxicity needs to be evaluated by laboratory testing with freshwater or marine aquatic test organisms appropriate for the receiving waters.

10.5.2 Hazardous Wastes

Most often concerns about hazardous wastes arise from constituents present in the source water or used to enhance the performance of RO membranes. Although RO concentrate may not be classified as a hazardous waste, it is possible that the brine and semisolid material resulting from the further processing of the concentrate could be classified as such. Guidance on handling hazardous and nonhazardous DWTF residuals may be found in a U.S. EPA (2006) document addressing the identification and disposal of these materials.

10.5.3 Naturally Occurring Radionuclides

In some parts of the United States, RO concentrate can contain naturally occurring radionuclide material (NORM). Although NORM concentrations in the RO concentrate may be low, they possibly could become a concern when the RO concentrate is concentrated further for disposal. Some guidance on the management of RO concentrate containing high concentrations of NORM may be found in U.S. EPA (2005), which addresses radioactive residuals from DWTFs. The concentrated levels of NORM generally are referred to as “technologically enhanced, naturally occurring radioactive material” (TENORM) (U.S. EPA, 2015).

10.6 Cost of RO Concentrate Management

Although RO concentrate management costs are mentioned in Chapter 2, a discussion of costs also is included here because they may limit the cost effectiveness of DPR employing RO as compared to other reuse options. The costs associated with RO concentrate management are site specific and vary widely, depending on the characteristics and volume of the concentrate that must be managed. A range of RO concentrate disposal costs is provided in Table 10.3 for some of the disposal options presented in Table 10.2.

The cost data reported in Table 10.3 should be used only as a general reference. For example, the length of the pipeline from the treatment facility to the point of disposal (e.g., deep well injection or evaporation ponds) can vary from less than a mile to more than 30 miles. The cost of the injection well similarly depends on the depth of the receiving aquifer, which can vary from 2000 to 10,000 feet.

Table 10.3. Estimated Unit Cost, Including Capitalized and Operation and Maintenance Costs, for Selected RO Concentrate Disposal Options^a

Disposal Option	Cost Range ^b		Typical Cost ^b	
	\$/AF	\$/10 ³ gal	\$/AF	\$/10 ³ gal
Deep well injection	50–80	0.15–0.25	70	0.21
Evaporation ponds	140–175	0.43–0.54	155	0.48
Land application, spray	135–160	0.41–0.49	115	0.35
Brine line to ocean	110–150	0.35–0.38	115	0.35
Zero liquid discharge	700–850	2.15–2.61	775	2.38

Notes: ^aThe reported costs are based on an Engineering News Record Construction Cost Index of 9900. Value of index in 1913=100. ^bBased on a concentrate flow of 2 Mgal/d. $\$/10^3 \text{ gal} \times 325.892 = \$/\text{AF}$. RO=reverse osmosis.

Source: Adapted in part from Raucher and Tchobanoglous (2014).

10.7 References

Cath, T.Y.; Childress, A. E.; Elimelech, M. Forward Osmosis: Principles, Applications and Recent Developments. *J. Membrane Sci.* **2006**, *281* (1–2), 70–87.

Jordahl, J. *Beneficial and Non-Traditional Uses of Concentrate*. WateReuse Research Foundation: Alexandria, VA, 2006.

Mickley, M. C. Membrane Concentrate Management—State of the Science. Report No. 3 in *Proceedings of Water Innovation Symposium*, Joint Water Reuse and Desalination Task Force, American Water Works Association Research Foundation, and others, San Diego, CA, 2005.

Mickley, M. *Survey of High Recovery and Zero Liquid Discharge Technologies for Water Utilities*. WateReuse Research Foundation: Alexandria, VA, 2007a.

- Mickley, M. *Evaluations of High Recovery and ZLD Technologies and Applicability for Water Utilities*. WateReuse Research Foundation: Alexandria, VA, 2007b.
- Mickley, M. *Treatment of Concentrate. Desalination and Water Purification Research and Development Program*. Report No. 155, U.S. Department of the Interior, Water and Environmental Services Division, Water Treatment Engineering Research Team, Denver, CO, 2009.
- Raucher, R.; Tchobanoglous, G. *The Opportunity and Economics of Direct Potable Reuse*. WateReuse Research Foundation: Alexandria, VA, 2014.
- Sethi, S.; Drewes, J.; Xu, P. *Assessment of Emerging Desalination and Concentrate Treatment Methods*, Annual Conference and Exhibition, American Water Works Association, San Antonio, TX, 2006.
- Southern California Salinity Coalition and National Water Research Institute (SCSC and NWRI). *Ocean Disposal of Reverse Osmosis Reject*. Revised draft, National Water Research Institute: Fountain Valley, CA, 2014.
- Tchobanoglous, G.; Stensel, H. D.; Tsuchihashi, R.; Burton, F. L. *Wastewater Engineering: Treatment and Resource Recovery*, 5th ed. Metcalf & Eddy/AECOM, McGraw-Hill: New York, 2014.
- Voutchkov, N. *Desalination Engineering Planning and Design*. McGraw-Hill: New York, 2013.
- U.S. EPA. Radiation Protection: About TENORM, webpage last updated by the U.S. Environmental Protection Agency on June 29, 2015.
<http://www.epa.gov/radiation/tenorm/about.html> (accessed 9/3/2015)
- U.S. EPA. *Regulators' Guide to the Management of Radioactive Residuals from Drinking Water Treatment Technologies*, EPA 816-R-05-004. Office of Drinking Water, U.S. Environmental Protection Agency: Washington, DC, 2005.
- U.S. EPA. *A System's Guide to the Identification and Disposal of Hazardous and Non-Hazardous Water Treatment Plant Residuals*, EPA 816-F-06-001. Office of Drinking Water, U.S. Environmental Protection Agency: Washington, DC, 2006.

Chapter 11

Facility Operation

The production of advanced treated water (ATW) from an advanced water treatment facility (AWTF) involves the use of a number of advanced treatment processes. Continuous operation and maintenance (O&M) and monitoring are necessary to ensure that the ATW meets all public health objectives and the AWTF operates consistently and reliably. Beyond the engineering and facility design detailed in Chapters 6 and 7, the long-term success of direct potable reuse (DPR) projects will depend on the availability of capable staff to appropriately operate and maintain the AWTF. The salient aspects of operating and maintaining an AWTF are discussed in this chapter, including:

- What is the importance of facility operation with respect to the production of ATW?
- What is needed for facility startup and commissioning?
- What are the operator requirements for AWTFs?
- What are the requirements for an effective facility maintenance program?
- What is an operation plan, and how is it developed?

11.1 Overview of Facility Operations and Maintenance

O&M activities begin with the construction of a new AWTF and continue throughout the lifetime of the facility. During construction, treatment plant operators will have the opportunity to see how individual treatment processes are installed and what will be involved in routine maintenance. Once an AWTF is operational, effective O&M will be critical for the successful production of ATW. As new treatment processes are introduced, ongoing operator certification and training must be instituted. Furthermore, because the characteristics of wastewater are changing constantly, the O&M plan for the AWTF must be reviewed and updated continuously. Documenting plant performance is also an integral part of an O&M program.

11.2 Facility Startup and Commissioning

Bringing an AWTF online involves a number of activities, including facility startup, commissioning and acceptance, and initial operator training. Each of these activities is considered briefly in Sections 11.2.1 to 11.2.3. Process monitoring during startup, commissioning and acceptance, and long-term operation are considered in Chapter 9.

11.2.1 Facility Startup

Facility startup is the process of bringing online a new AWTF treatment train. Procedures and guidelines to be followed during startup generally are included in the contract documents. The startup procedure typically involves testing each individual process separately, testing processes in combination, and finally testing the entire treatment train. Each individual treatment process must meet both mechanical performance and water quality specifications

during the startup testing period. The water quality data obtained during startup are used to document and verify that system performance meets specifications. In most cases, the initial startup period is 30 days.

11.2.2 Commissioning and Acceptance

The advanced treatment trains for AWTFs often will include more complex and less familiar treatment processes, such as membrane filtration, reverse osmosis (RO), and advanced oxidation processes (AOPs). These treatment processes must be commissioned by experienced contractors who understand the importance of established practices, such as providing opportunities to properly flush away construction debris prior to placing the units into production. AOPs [such as ultraviolet (UV) or ozone disinfection] also require an experienced startup team that understands the importance of properly purging the ozone generator prior to initiating production and has the knowledge to assess whether the intended UV dose is being delivered.

Another critical component in the commissioning of an AWTF is the presence of an experienced operations person (e.g., an integrator) who will be responsible for the overall startup effort. This integrator can ensure proper communication between the startup team and facility operators, as well as make minor field modifications to the programming and monitoring required for a smooth startup.

The commissioning and acceptance period can vary from 30 days to 6 months, depending on the complexity of the processes employed at the AWTF. Equipment warranties can vary from 1 to over 5 years.

11.2.3 Initial Operator Training

The operations staff needs to be engaged throughout the entire design and construction of the AWTF. The startup and facility commissioning period is a key time for senior operations staff to engage with equipment manufacturers and experienced contractors. This interaction will provide a unique opportunity to familiarize operations staff with proper operating conditions and how to avoid damaging essential equipment.

11.3 Operation during the First Year

The operation of an AWTF during the first year is a critical period for the long-term success of the DPR project for a number of reasons:

- During the commissioning period, operations staff will work side by side with the personnel responsible for facility commissioning, giving the operations staff time to become thoroughly familiar with the advanced treatment process
- During the first year of operation, site-specific standards must be reviewed and modified so operating staff will know when the treatment train is operating properly and when to make corrections.
- Most equipment operational problems that need to be corrected will become evident during the first year of operation

11.3.1 Relationship of Operational Staff and Suppliers

It is recommended that operations staff remain engaged with the equipment manufacturers to receive the advice and council necessary to operate the equipment. Operations staff also should seek guidance from trained engineering or operating professionals with experience overseeing and ensuring the successful operations of such facilities. The advice of trained professionals is valuable in overseeing interrelated issues and providing third-party guidance and advice to the operations staff.

11.3.2 Examples of First-Year Challenges

Common examples of issues experienced during the first year of operation include maintaining a proper chlorine residual and quenching the ozone residual so that carryover does not occur to biological processes, such as a biological filter. Operations staff will need to be trained thoroughly to handle these issues. Although the first year is the most critical period, long-term support for the operations staff is important and recommended to address issues associated with AWWTF operations.

11.4 Advanced Water Treatment Facility Operators

A competent operations staff will need to be trained properly to address the challenges that may arise at an AWWTF. Organizations such as the American Water Works Association (AWWA), Water Environment Federation (WEF), International Ultraviolet Association, and individual state associations administer a number of operator training programs that cover all aspects of conventional water and wastewater treatment (including hands-on training, information on educational workshops and conferences, access to publications, and opportunities for networking with peers in the field).

If membrane technologies are used, operations staff will need proper training and knowledge on industry best practices. To accomplish this training, operations staff should receive managerial and financial support to engage in regional membrane training offered by organizations such as the American Membrane Technology Association and its affiliates like the Southwest Membrane Operators Association.

11.4.1 License Requirements

Operator license requirements for AWWTFs are anticipated to evolve. At present, AWWTFs are operated by personnel with wastewater operator's licenses. As the number of operational AWWTFs expands, it is anticipated that operators with drinking water licenses also will be employed. If finished water facilities (see Chapter 2) are implemented, drinking water operator's licenses will be required because such facilities must be permitted as drinking water treatment facilities (DWWTFs).

11.4.2 New Category of Certification

DPR projects are unique in that they will require operations staff with expertise in wastewater treatment, drinking water treatment, and water quality, as well as advanced treatment. To date, existing operator licenses are divided into categories of "wastewater" or "drinking water," and there is no official operator license or training for "advanced treatment technologies," which is needed for AWWTFs. The grade of operator required for both

wastewater treatment plants (WWTPs) and DWTFs depends on the size of the facility. With advanced treatment processes for potable reuse, the degree of expertise required is the same regardless of the size of the facility.

11.4.3 Continued Training

Operators should maintain expertise in wastewater treatment through local training opportunities or seek national support through WEF and its associated members. In addition, lead operations staff for AWTFs should remain current with drinking water regulations and constituents of concern (COCs), and support for this knowledge base should be obtained from AWWA and its state sections. Drinking water regulatory knowledge and expertise is necessary for any DWTF; therefore, the operational leadership of an AWTF will need to understand the implications of decisions on the safety of the drinking water that it will produce.

11.5 Advanced Water Treatment Facility Maintenance

Proper maintenance is imperative to protect the capital investment of any water processing facility, but it is even more critical for DPR projects to ensure successful operation and protection of public health. The maintenance staff at an AWTF should be as large as the operations staff and perform all the preventive maintenance necessary to ensure proper operation of the mechanical equipment and online meters. An effective facility maintenance strategy would have some form of an asset management program and software to ensure that required maintenance is scheduled and performed prior to potential equipment failure.

For example, some important tasks include: meter calibration and component/consumable replacement, membrane fiber and header repairs, bulb replacement for UV lamps, compressor and blower maintenance, and investigating conductivity issues within identified membrane vessels. Proactive maintenance programs should be designed to enable operations staff to maintain treatment processes at proper operating conditions and minimize the frequency and duration of inadequate equipment performance.

11.6 Operations Plan

An operations plan is recommended for any AWTF. It should include:

- An organizational chart with the names of staff members currently assigned to each supervisory or leadership position
- A bulleted list of job responsibilities for each classification to ensure clear pathways of communication and well-defined roles
- A simplified description of: (1) the overall facility; (2) treatment objectives and responsibilities of the facility; and (3) the basis of the design for key unit processes, along with typical operating conditions, acceptable ranges, and alarm conditions
- Provisions for the preparation of an annual operations report

11.6.1 Goal of the Operations Plan

The overall goal of the operations plan is to provide operations staff with the ability to make decisions quickly and communicate with management based upon a documented and agreed-upon set of norms and conditions that would cause alarm; therefore, the development of an operations plan manual is critical to ensuring the long-term performance of the AWTF. To be of value (especially for new employees), the operations plan manual must be updated continuously. It is also possible to develop an interactive manual in which the solution of past problems can be archived for easy reference.

11.6.2 An Example of an Operations Plan Manual for an Advanced Water Treatment Facility

The Orange County Water District (OCWD) in California has been producing ATW for indirect potable reuse (IPR) through the Groundwater Replenishment System (GWRS) since 2008. Since then, OCWD has maintained an operations plan manual for its AWTF. Considered a living document, the manual is revised as new experience is gained. It is designed to address the operation of the individual components that make up the AWTF, as shown in Figure 11.1. Topic areas addressed in the manual are summarized in Table 11.1. The circled numbers in Figure 11.1 correspond to sections of the manual listed in Table 11.1.

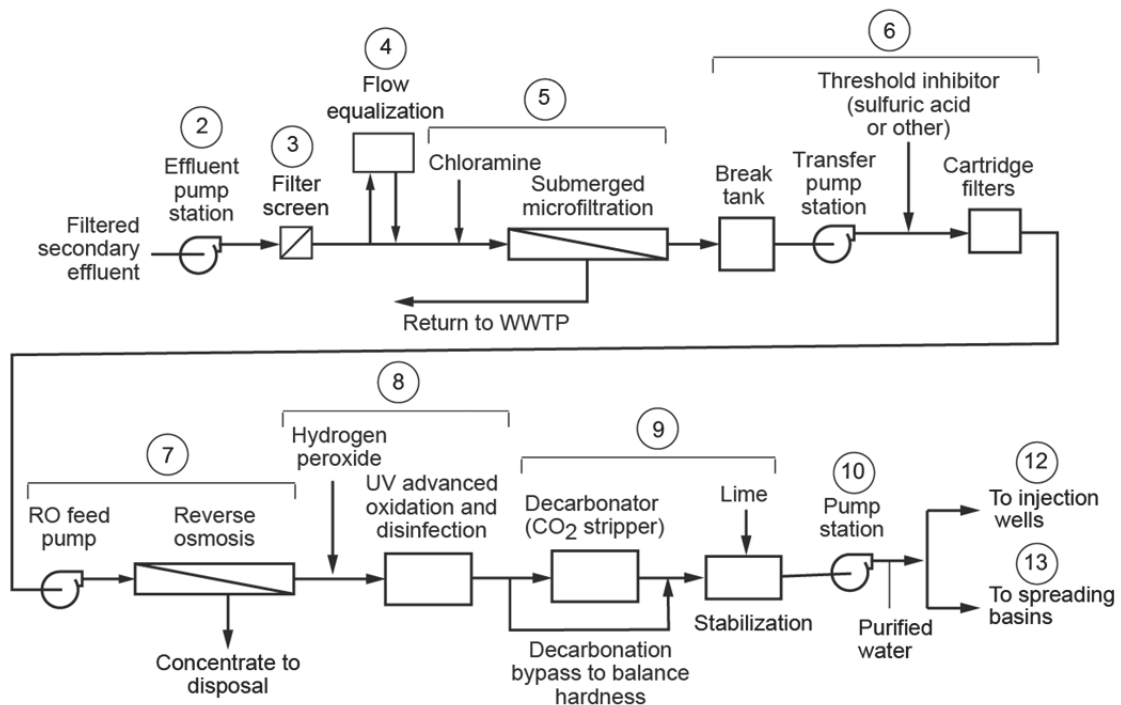

Figure 11.1. The flow diagram for the AWTF at the Orange County Water District.

Note: The circled numbers correspond to the sections of the operations manual described in Table 11.1.

For each of the major components of the AWTF, the contents of the manual are organized under the following subheadings: (1) description; (2) design data; (3) process schematics;

(4) control; (5) operations; (6) alarms; (7) equipment; (8) safety; and (9) process performance monitoring. The discussion under each of these sections is comprehensive (see Table 11.2) so that an operator has access to all pertinent information needed to troubleshoot any problem that may arise.

Table 11.1. Topic Areas Addressed in the Operations Plan Manual Developed for the AWTF Shown in Figure 11.1

Section	Topic Area	Description
1	Overview	Overall description of AWTF and introduction to all subsystems by work area and function
2	Air gap structure and pump station	Description, design data, process schematics, operation alarms, equipment, safety, process monitoring
3	Influent screening facilities	Description, design data, process schematics, control, operations, alarms, equipment, safety, process performance monitoring (see Table 11.2)
4	Secondary effluent flow equalization	As above in Operations Plan Manual Section 3
5	Microfiltration system	As above in Operations Plan Manual Section 3
6	Chemical storage and feed systems/cartridge filters	As above in Operations Plan Manual Section 3
7	Reverse osmosis	As above in Operations Plan Manual Section 3
8	Advanced oxidation/disinfection process	As above in Operations Plan Manual Section 3
9	Decarbonation/post-treatment stabilization	As above in Operations Plan Manual Section 3
10	Product water pumping facilities station	As above in Operations Plan Manual Section 3
11	Substation/switchgear building	As above in Operations Plan Manual Section 3
12	Injection wells	As above in Operations Plan Manual Section 3
13	Spreading basins	As above in Operations Plan Manual Section 3
14	Plant utilities	Introduction; process components; process analysis, control and troubleshooting; preventive maintenance; description of power, backup power, water supply, waste disposal for processes
15	Process control system overview	Description, design data, process schematics, control, operations, alarms, equipment, safety, process performance monitoring (see Table 11.2)
16	Water quality monitoring	Introduction to AWTF with respect to water quality (including influent, recycled water, and reject streams), groundwater quality monitoring, diluent water quality monitoring, and reporting requirements
17	Staffing, quality assurance, and contingency plans	Staffing plan; organizational chart with roles; responsibility matrix for facility, including assignments to specific unit process area(s); laboratory and quality assurance procedures; contingency plan

Source: Adapted from OCWD (2015a).

Table 11.2. Example of Items Addressed within Each Topic Area Identified in Table 11.1

Subheading in Topic Area	Items Included
Description	Description of facilities or unit processes, functional overview (role in treatment process), regulatory requirements
Design data	Data used for unit process design under various flow regimes
Process schematics	Schematics for unit processes, including operation, mechanical, electrical elements, interrelationships with other unit operations
Control	Control strategy and instrumentation provided for unit processes
Operations	Process operational modes, troubleshooting procedures, standard operating procedures, emergency procedures, operations staffing
Alarms	Description of alarm triggers and response/actions
Equipment	Maintenance activities, mechanical troubleshooting, safety, identification of critical components, timeline to procure
Safety	Safety procedures for equipment operation, chemical handling and spills, response procedures for emergencies
Process performance monitoring	Description of data logging procedures, analysis, assignments, preparation of data summaries

Source: Adapted from OCWD (2015a).

11.6.3 Preparation of Annual Reports

Annual reports typically are prepared for three reasons:

- Fulfill the requirements of the permit to operate, as specified by the regulatory agency
- Provide an in-depth review and critical evaluation of facility operation in meeting stated water quality objectives
- Maintain a historical record of facility operation

The extent of the annual report depends on the number of components that make up the AWTF. For the purpose of illustration, the topics covered in the portion of the OCWD GWRs 2014 Annual Report (OCWD, 2015b), which deals with the performance of the AWTF (see Figure 11.1), are reproduced in Table 11.3.

As shown in Table 11.3, the performance of the AWTF with respect to the quality of water is based on a consideration of the quantity of ATW produced, quality of the source water (e.g., treated wastewater), water quality performance of the individual processes, and overall process performance with respect to nitrogen and total organic carbon (TOC). The next part of the annual report addresses performance and compliance records for the individual treatment processes and the overall monitoring record for pathogen log reduction and compliance with chemical constituents.

Table 11.3. Example of Items Addressed in the Annual Report with Respect to the Performance of the OCWD AWTF Shown in Figure 11.1

Chapter 2: WATER PURIFICATION FACILITY PERFORMANCE

Section 2.1: Purified Recycled Water Volume and Flows

Section 2.2: Purified Recycled Water Quality

- 2.2.1 Source Water Quality
- 2.2.2 MF System Performance
- 2.2.3 RO System Performance
- 2.2.4 UV-AOP Performance
- 2.2.5 Total Nitrogen Removal
- 2.2.6 Total Organic Carbon Removal

Section 2.3: Performance and Compliance Record

- 2.3.1 General Operational Performance
- 2.3.2 Critical Control Points
- 2.3.3 Source Water Availability (i.e., secondary effluent)
- 2.3.4 Source Water Quality
- 2.3.5 MF System Operation and Performance
- 2.3.6 RO System Operation and Performance
- 2.3.7 UV-AOP Operation and Performance
- 2.3.8 Decarbonation and Lime System Operation and Performance
- 2.3.9 Summary of GWRS Pathogen Log Reduction Monitoring in 2014
- 2.3.10 Contaminants of Emerging Concern Monitoring and Compliance with Amended State Water Resources Control Board Recycled Water Policy

Section 2.4: Santa Ana River Discharges

Section 2.5: Anticipated Changes

Notes: AOP=advanced oxidation process; GWRS=Groundwater Replenishing System; MF=microfiltration; RO=reverse osmosis; UV=ultraviolet.

Source: OCWD (2015b).

11.7 References

OCWD. *Groundwater Replenishment Systems Operation, Maintenance, and Monitoring Plan. Draft*, Orange County Water District: Fountain Valley, CA, 2015a.

OCWD. *Orange County Water District Groundwater Replenishment System 2014 Annual Report*. Report prepared by D. L. Burris of DDB Engineering, Inc., Irvine, CA, for the Orange County Water District: Fountain Valley, 2015b.

Chapter 12

Public Outreach

Public outreach is one of three principal components of a direct potable reuse (DPR) program. It is an essential tool in building public confidence and allaying fears about using advanced treated water (ATW) as a water supply source. Experience has shown that public perception and support of potable reuse can be increased within a community through proactive, appropriate, and consistent outreach. A municipality, utility, or agency involved with a DPR project should organize a public outreach program that launches early in the process (i.e., during project planning) and is maintained throughout the lifetime of the project. Proven resources are available to help agencies develop outreach and communication strategies for water supply projects; such resources are growing for DPR in particular. Examples of public outreach strategies for DPR are included in this chapter. Other aspects of outreach considered in this chapter include:

- Why establish the need for potable reuse within the community?
- What constitutes DPR public outreach?
- What are the challenges associated with DPR outreach?
- What is involved in the development of a communication plan for DPR?
- What examples are available of potable reuse outreach programs?

Although outreach strategies specific to source control are discussed separately in Section 5.5, they can be incorporated into the overall DPR public outreach program described in this chapter.

12.1 Establishing the Need for Potable Reuse

Before proceeding with a potable reuse project, the responsible agency must demonstrate that additional water supply is needed to ensure the well-being of the community. As part of this effort, the agency should consider all feasible water supply alternatives. Then a clear rationale will be needed as to why a particular project or projects were selected for implementation. Having such justification will help raise public confidence in the value of the project, as well as assure the public that it is the best solution for the community.

12.2 Overview of Public Outreach for Direct Potable Reuse

Because potable reuse is not a mainstream topic in most communities, the purpose of public outreach should be to build awareness, trust, confidence, support, and acceptance of planned potable reuse projects. Individuals will then decide whether to consume this water (as is the current situation with public water supplies).

To achieve this end, outreach for DPR projects should embrace the following concepts (Millan et al., 2015):

- Make the outreach program strategic, transparent, and thorough
- Build on lessons learned from existing potable reuse projects, research on relevant issues like CECs, and available communication strategies (such as risk communications)
- Start outreach early and engage the public throughout the lifetime of the project
- Use proven techniques and tools to listen to and communicate with the community, engage the media, and address public concerns
- Provide useful information to explain the role of water reuse in the water cycle, increase awareness of the value of potable reuse, and build confidence in the quality of ATW
- Create messages that are consistent and communicated to the entire community, including different audiences
- Build relationships with influential community members (e.g., opinion leaders)
- Create transparency in all aspects of the project, including costs, water quality, and safety
- Prepare for tough questions and address misinformation

An agency would ideally craft a targeted outreach program for the DPR project specifically. The program would reflect specific communication objectives, types of communication tasks needed, and level of effort required to address directly public perception challenges.

12.3 Challenges Associated with Outreach for Direct Potable Reuse

As with any water supply project, challenges may arise with DPR (and vary from community to community) that could impact the public's perception for the need and benefits of ATW. For example, fear of contaminated water may result in skepticism of the quality of ATW produced at an advanced water treatment facility (AWTF) (NRC, 2012). A list of possible outreach challenges for DPR is presented in Table 12.1.

Proponents of DPR projects should identify their specific outreach challenges and methods to address them within the communication plan, which is described in Section 12.4.

Table 12.1. Examples of Communication and Outreach Challenges

Type of Challenge	Specific Concerns
Concerns about current water supply	<ul style="list-style-type: none"> • Mistrust of drinking water quality. • Lack of knowledge about current water supply. • Increased use of point-of-use filters and bottled water. • Distrust of water suppliers and government agencies.
Perceptions about potable reuse	<ul style="list-style-type: none"> • The “yuck factor,” which is a strong (but natural) reaction that can cause low initial acceptance of DPR projects. • Water quality concerns, including those reported in the media, such as methyl tertiary-butyl ether, perchlorate, chromium-6, and CECs (pharmaceuticals, hormones, endocrine-disrupting compounds, and industrial chemicals). • Potable reuse viewed as a “last resort” rather than as a sustainable alternative that benefits the community. • Impacts on the environment from managing residuals or reducing water released to the environment (i.e., wastewater discharge). • Businesses (such as soft drink bottlers) viewing recycled water as negatively affecting their brands.
Community opposition to the project	<ul style="list-style-type: none"> • Environmental justice issues (e.g., only certain demographics receive the ATW). • Opponents concealing true motivations (such as antigrowth). • Opposition occurring late in project development. • Costs of water and increasing rates.

Notes: ATW=advanced treated water; CEC=constituent of emerging concern.

Source: Millan et al. (2015).

12.4 Having a Communication Plan

The information provided in this section describes the purpose of the communication plan and includes examples of factors that could influence developing these plans for potable reuse, possible communication strategies, and suggested outreach tools and materials. It is neither a comprehensive list nor a checklist.

A number of communication planning tools and guidance materials pertaining to the water industry are available from organizations like the American Water Works Association (AWWA, no date), Centers for Disease Control and Prevention (CDC, 2013), and WateReuse Research Foundation (e.g., Humphreys, 2006; Ruetten, 2004; Tennyson, 2014); however, a suggested resource for developing a DPR-focused communication plan is “Model Communications Plans for Increasing Awareness and Fostering Acceptance of Potable Reuse” (Millan et al., 2015), which was published by WRRF.

12.4.1 Purpose of the Communication Plan

The written communication plan should contain a detailed set of strategies used to communicate about the project to the public, elected officials, and others. The plan should be comprehensive and include messaging, outreach tools, and communication strategies. It also should be flexible enough to adapt to the needs of specific locations and situations.

12.4.2 Key Factors for Developing the Communication Plan

A number of factors can influence the scope of the outreach program outlined in the communication plan, such as those listed in Table 12.2. These factors should be considered when developing the communication plan.

12.4.3 Outreach Strategies Identified in the Communication Plan

Various outreach strategies can be used by an agency to engage its community and gain support of a potable reuse project. These strategies should be outlined in the communication plan and should be audience specific (Millan et al., 2015). Examples of some possible outreach strategies are listed in Table 12.3.

Table 12.2. Key Factors that Should Be Considered When Developing a Communication Plan

Factor	Significance
Schedule and duration	Communication should start early in the process, before project selection, and must continue throughout the design, construction, startup phases, and lifetime operation of the AWTF.
Purpose of communication	Communication activities should have a clearly stated purpose, which is used to support decisions.
Messages	Messages should provide a framework for understanding need for the project, including a narrative to engage the public, raise awareness, and gain acceptance. They should be consistent, accurate, and understandable to a nontechnical audience.
Terminology	Uniform terminology has not been developed for potable reuse, but specific projects have produced terminology that has been effective on a local level. Accessible terms like “advanced purified water” and “purified water” are more effective with the public than industry jargon like “potable reuse” and “IPR.” Technical terms not understood by the public may not resonate well even when explained.
Problem solving	A clearly articulated problem will help the public better understand and support the need for potable reuse; define the water supply condition that will be resolved by the project. Another best practice is to create a perception of improvement (i.e., the project is improving the quality of life and making things better for the community).

Factor	Significance
Anticipated outcomes	The benefits and outcomes of the outreach program should be broad and include public agreement that wastewater is a resource and should be recycled; community trust in the agency to implement DPR that produces safe, high-quality water to provide a reliable water supply; and a public commitment to transparency and seeking community engagement and involvement in project.
Costs and benefits	Financial considerations may be the primary concern of some communities. Clear and transparent explanation of costs is necessary to gain public confidence, especially if the DPR project is not the least expensive option. The conversation on project costs should include a discussion of benefits (e.g., water reliability and sustainability). Economic development may be an important benefit to some stakeholders.
Competing issues	Communities must consider a number of priority issues, ranging from education to economy. Water reliability and sustainability are part of the community's discussion, and consideration is needed to illustrate the link between water supply and other important community topics.
Demographics and environmental justice	Because certain demographic groups are less likely to support DPR, attention should be given to communicating with them. These include women with children at home, minorities, less educated/less affluent individuals, non-English speakers, and senior citizens. They may also be concerned with environmental justice issues.

Notes: AWTF=advanced water treatment facility; DPR=direct potable reuse; UPR=indirect potable reuse.

Sources: Millan et al. (2015) and Ruetten (2004).

Table 12.3. Examples of Potable Reuse Outreach Strategies

Element/Tactic	Details
Research on public perception	Telephone surveys, one-on-one stakeholder meetings, focus groups, and other research activities can be used to assess community concerns and gain an understanding of public perception and acceptance. Results can inform the development of the outreach strategy.
Audience identification	Communication with diverse audiences is needed because each group may present potential challenges to effective outreach. Specific audiences that require distinct outreach efforts include opinion leaders, community leaders, community organizations, and youth. Maintaining a database of individuals categorized by audience can be helpful in organizing outreach efforts.
Internal communication	Include an internal outreach component to educate agency staff members. Customers or friends and neighbors may approach staff members with questions about DPR; it is important that the agency provide a consistent message.
Outreach to opinion leaders	Identify opinion leaders in individual communities, as they influence the attitudes and behaviors of others. This group should be made aware of the need to increase water supply sources and the use of ATW as a water supply option.

Element/Tactic	Details
Outreach to other important leaders	These leaders include academic and educational staff; business organizations; civic groups; environmental organizations; water wholesalers and retailers; state and local elected officials and staff; medical, public health, and water quality experts.
Written materials	Written materials must present confident messages. Possible formats include briefing binders, e-mail listservs, event invitations, brochures and flyers, newsletter articles, press releases, direct mail, websites, and social media.
Personal interaction	Meetings and presentations are needed to reach out to all identified stakeholders. Personal interactions can be in the form of one-on-one, town hall, and civic meetings; neighborhood gatherings; and formal presentations,. Board members and elected officials should be involved in addition to agency staff.
Identify supporters and champions	Agencies can use individuals or organizations as partners or supporters. In addition to voicing support, these partners become public advocates.
Message plan	Messages can be developed for both general and specific audiences affected by a project. Messages should describe ATW, underscore safety of water and protection of public health, and provide costs and benefits (e.g., increased water reliability and sustainability). Informational material needs to be developed and spokespeople trained to deliver the information.
Communicate effectively	Guidance for effective communication includes training all project spokespeople; reviewing messages for consistency in presentations, interviews, and meetings with stakeholders; and ensuring written materials reflect the information provided in oral communications.
Letters of support	After a presentation or meeting, agency staff should request a letter of support for project from appropriate audience members. Post these letters on project website and use them to reach out to other stakeholders.
Common questions and answers	Be prepared with answers to common questions. Information can be provided in written format, as well as in briefing materials.
Address difficult issues	Be prepared to address difficult topics raised by stakeholders. If needed, seek assistance from experts in the field, including academics, medical doctors, public health officials, and other credible individuals.
Other specialized needs	Other issues may need to be addressed as part of project. For example, risk communication and management expertise may be needed in response to stakeholder questions. These fields of study often are used in communicating and managing risks associated with public health.

Notes: ATW=advanced treated water; DPR=direct potable reuse.

Sources: Millan et al. (2015) and Ruetten (2004).

12.4.4 Communication Plan Tools and Materials

An effective potable reuse outreach communication program should provide objective information with consistent messages and meaningful terminology suitable for diverse audiences (Millan et al., 2015). Potential tools and materials used to disseminate this information are listed in Table 12.4.

Table 12.4. Examples of Communication Plan Tools and Materials

Tools/Materials	Purpose/Examples
Printed materials	Fact sheets, frequently asked questions, brochures, bill inserts, posters and banners, materials for youth and children, white papers.
Digital materials	Project website; slide presentations; e-newsletters; videos.
Mailing lists	To communicate to different groups for different purposes; mailing lists can be electronic or physical.
Centralized internal information system	To catalogue and store materials.
Media outreach	To provide timely information and ensure media are informed, as well as to address misinformation. Examples: spokespeople, media training, contacts, articles, tours, and responding to media requests.
Social media	To reach certain segments of the population and provide information on a real-time basis.
Speakers' bureau	To facilitate opportunities to speak at group meetings, including business leaders, civic groups, and environmental, multicultural, and other community groups.
Stakeholder groups	To provide a process for input and feedback from interested parties within a community. Stakeholder group members can become important supporters of the project.
Demonstration facility/visitor center	To provide a positive learning experience for participants. Visitor centers involve educational displays and materials; demonstration facilities show treatment processes and treated water for examination. If possible, allow visitors to taste the product water.
Independent advisory panels	To provide credibility and validation of a project. Local physicians and national experts in health, water quality, and technology can provide an independent viewpoint and make recommendations for improvement.
Rapid response plan	To swiftly address unexpected events related to the project.
Monitoring and evaluation	To provide measureable outreach objectives that can be reviewed periodically. Results of review will provide feedback for adapting or changing communications plan, tools, and materials.

Source: Millan et al. (2015).

12.5 Examples of Outreach Programs for Potable Reuse Projects

A growing database of information is available to support outreach activities by agencies planning or implementing potable reuse projects, including research studies (Millan et al., 2015) and existing potable reuse projects as case studies. Examples of existing potable reuse projects in the United States with outreach programs are included in Table 12.5. Proponents of DPR projects are encouraged to communicate with agencies that have existing potable reuse projects to learn more about their experiences in reaching out to the community. One valuable activity in researching outreach programs would be to send appropriate staff (e.g., outreach/public relations personnel, board of directors, project managers, and others involved with communicating about the project) on tours of existing potable reuse demonstration facilities or visitor centers.

Table 12.5. Examples of Potable Reuse Projects in the U.S. with Outreach Programs

Project	Agency	Type	Status
Direct Potable Reuse Project	Wichita Falls, TX	DPR (emergency water supply)	Operational since 2014
Groundwater Replenishment System	Orange County Water District and Orange County Sanitation District, CA	IPR for groundwater recharge	Operational since 2008
Los Angeles Groundwater Replenishment Project	Los Angeles Department of Water and Power, CA	IPR for groundwater recharge	To be operational by 2022
Pure Water San Diego	San Diego, CA	IPR for reservoir augmentation; considering DPR	To be operational by 2023
Silicon Valley Advanced Water Purification Center	Santa Clara Valley Water District, CA	Proposed potable reuse project	AWTF operational since 2014

Notes: AWTF=advanced water treatment facility; DPR=direct potable reuse; IPR=indirect potable reuse.

12.6 References

American Water Works Association (AWWA). Public Communications Toolkit, webpage not dated.

<http://www.awwa.org/resources-tools/public-affairs/communications-tools/public-communications-toolkit.aspx#2213174-strategic-planning> (accessed 9/3/2015)

CDC. Drinking Water Advisory Communications Toolbox, webpage last updated by the Centers for Disease Control and Prevention on March, 2013.

<http://www.cdc.gov/healthywater/emergency/dwa-comm-toolbox/before/organizing.html#consult> (accessed 9/3/2015)

Humphreys, L. *Marketing Nonpotable Recycled Water: A Guidebook for Successful Public Outreach & Customer Marketing*, Project Number WRF-03-005-01, WaterReuse Research Foundation: Alexandria, VA, 2006.

Millan, M.; Tennyson, P. A.; Snyder, S. *Model Communication Plans for Increasing Awareness and Fostering Acceptance of Potable Reuse*. Project Number WRRF-13-02. WateReuse Research Foundation: Alexandria, VA, 2015.

NRC. *Water Reuse: Potential for Expanding the Nation's Water Supply through Reuse of Municipal Wastewater*. National Research Council, National Academies Press: Washington, DC, 2012.
http://www.nap.edu/catalog.php?record_id=13303 (accessed 9/3/2015)

Ruetten, J. *Best Practices for Developing Indirect Potable Reuse Project: Phase I Report*. Project Number WRF-01-004. WateReuse Research Foundation: Alexandria, VA, 2004.

Tennyson, P. A. *Development of Public Communication Toolkit for Desalination Projects*. Project Number WRRF-12-02-01. WateReuse Research Foundation: Alexandria, VA, 2014.

Chapter 13

Future Developments

The feasibility of using advanced treated water (ATW) for both groundwater and surface water augmentation has been proven, and a number of systems are operating currently. A thorough review and summary of future needs necessary to broadly address potable reuse were identified in the 2012 National Research Council (NRC) report on *Water Reuse* (NRC, 2012). The NRC list of priority needs is not repeated in this chapter. Rather, the purpose of this chapter is to highlight some future needs to: (1) reduce the potential for overly conservative designs inherent in the early implementation of potable reuse; and (2) develop the information necessary to allow for permitting advance water treatment facilities (AWTFs) to provide finished water that can be introduced directly into a drinking water distribution system. Future needs addressed in this chapter, based on the three key components of a DPR program described in Chapter 3, include:

- What are future regulatory needs?
- What are future technology needs?
- What are future public outreach needs?

13.1 Future Regulatory Needs

Because an effective regulatory system already is in place for public water supplies and for the discharge of treated wastewater effluent to the environment, it is possible to adapt the current requirements of the Safe Drinking Water Act (SDWA) and Clean Water Act (CWA) regulations to ensure potable water produced from wastewater is treated adequately. Until specific guidelines or regulations are crafted for potable reuse, critical elements of the DPR program will need to be based on good engineering practice, as described in this framework document. Regulatory guidance is expected in the near future in California and may be developed in other states facing pressing needs for the consideration and application of DPR. As these regulatory guidelines are developed, it is important to consider the following:

- Maintaining consistency with existing regulations
- Recognizing and improving the strengths of available technologies to minimize potential public health risks
- Ensuring adequate attention to treatment process control and operation and maintenance (O&M)
- Supporting operator training and certification needs
- Supporting communication with the public on the safety and challenges associated with implementing DPR

13.1.1 Need for Future Guidelines and Regulations

In this document, a framework is provided to assist agencies and regulators as they consider implementing DPR projects in the absence of guidelines and regulations. As more experience and research are gained in the understanding of DPR, specific guidance and standards may be developed.

13.1.2 Development of a National Framework on Integrating the CWA and SDWA Permitting Approach to Streamline and Assist State Implementation of Direct Potable Reuse

No federal regulations specifically address water reuse; however, several regulations have bearing on water reuse projects. For example:

- The CWA with regard to water quality for discharge to receiving waters
- The CWA relative to the regulation of discharges to publicly owned treatment works (POTWs) (e.g., source control and pretreatment regulations)
- The SDWA relative to the protection of water supply sources [e.g., source assessments and risk reduction barriers as part of the source water protection program (SWPP)]
- The SDWA relative to drinking water treatment requirements for different source waters (e.g., the Long-Term 2 Enhanced Surface Water Treatment Rule)

Treatment technologies capable of producing high-quality potable water from wastewater (i.e., ATW) for supplementing drinking water supplies have been demonstrated in a number of full-scale AWWTFs. In the absence of federal regulations, a number of states are moving to recognize DPR within state law. For example, in California, water recycling “constitutes the development of new basic water supplies.”⁹

Although states maintain primacy relative to permitting POTWs, drinking water sources, and associated water treatment facilities, national guidance in which the provisions of the CWA and SDWA are integrated as they relate to potable reuse could help states develop regulations to more efficiently and effectively manage and consistently regulate the growing demand for potable reuse. Until national guidance is developed that integrates federal laws and regulations as they relate to potable reuse, the material presented in this framework document can be used by states investigating the feasibility of developing DPR regulations to ensure adequate protection of public health without overburdening utilities with numerous regulatory requirements and constraints.

13.1.3 Understanding Operator Training and Certification Needs for Direct Potable Reuse

Once an appropriate treatment train has been designed and implemented for a DPR project, it is critical that the treatment and monitoring processes be operated, maintained, and calibrated properly on a continuous basis. Robust process design, effective operational management,

⁹ California Water Code, Division 7, Chapter 7—Water Reclamation, Article 2—Declaration of Policy, §13511—Legislative Findings.

ongoing maintenance and replacement programs, and comprehensive response procedures can achieve consistent levels of operational reliability for AWTFs; however, even with these design and operational features, the operators of AWTFs must be able to evaluate and respond to any treatment issues that may arise. Remote operation without operators onsite at AWTFs is not advisable until more confidence is gained in treatment and online performance monitoring systems.

13.1.3.1 Need for Operator Training and Certification

Because many of the technologies for the production of ATW and finished water are complex and the source water is a greater treatment challenge, AWTFs must be operated by a well-trained, highly skilled operations staff. Many of the required skills are beyond what is needed currently for conventional wastewater and drinking water operators. Producing ATW of high quality requires operators who understand:

- The details of each technology, including critical control points (CCPs), calibration of monitoring tools, performance expectations, and impacts of upstream water quality failures on downstream processes.
- The underlying health objectives and need for extensive water quality monitoring before and after each treatment process.

13.1.3.2 Need for Guidelines to Assist State and Trade Organizations in Establishing Consistent and Effective Operator Training and Certification Programs for Direct Potable Reuse

Because operations staff will be responsible for a variety of activities related to the safety of potable water, they will require appropriate training and certification in the operation of advanced treatment processes. Existing operator licenses, as noted in Chapter 11, are divided into categories of “wastewater” or “drinking water.” No official operator license or training exists for “potable reuse” or “advanced treatment technologies.” As a result, current potable reuse operators rely on existing water and wastewater certifications.

What is needed is a training and certification program that is consistent with the treatment technologies and water quality requirements for potable reuse. For instance, a new category of certification could be established for an “advanced treatment technologies operator,” which encompasses water quality, drinking water treatment, and wastewater treatment technologies. Regardless of the specific title, the development of guidelines for operator training and certification for AWTFs is a high priority.

13.2 Future Technology Needs

Although the pace of technological developments in the field of potable reuse in the past 10 years has been dramatic, a number of issues related to ensuring the safety of the ATW or finished water need to be better understood, including:

- Access to more real-time monitoring tools to address failure events
- The relationship between multiple barriers
- The relationship and value of environmental buffers and engineered storage barriers (ESBs)

- A more effective mechanism for the compilation and sharing of AWTF operation and performance data

13.2.1 Better Monitoring Methods and Tools to Capture and Distinguish Failure Events

It is not practical to use the direct measurements of some contaminants to assess treatment processes and identify failure events when ATW is used for DPR. Indicators, surrogates, and treatment process parameters are used to estimate the removal of many pathogens and constituents of emerging concern (CECs). Some monitoring techniques require extensive time periods to obtain results. Research is needed to further develop indicators, surrogates, and other parameters that can reliably monitor ATW quality and individual treatment processes in real or near-real time.

13.2.2 Better Understanding of the Relationship between Multiple Barriers

The current understanding of multiple barriers is that each unit process used in the treatment train to remove specific types of pathogens and chemical constituents is considered mathematically independent. The concept of non-independence, although discussed theoretically, has not been addressed in a rigorous fashion for these constituents. Research is needed to address this information gap so that assumptions regarding potential human exposure and public health risk are estimated more accurately in the event of a deviation from performance specifications for a particular unit process in the multiple-barrier sequence being employed.

13.2.3 Characterizing the Relationship between Environmental Buffers and Engineered Storage Barriers

The public health protection provided by an environmental buffer (i.e., a groundwater basin or surface water reservoir) is being required currently in some states (e.g., California) as part of IPR criteria and state regulations. Although research is ongoing to better define and characterize ESBs, a significant need exists to translate that research in a manner that makes practical sense for application to DPR projects. For example:

- Is the translation strictly providing additional ESBs?
- Could real-time monitoring of selected surrogates or indicators be a possible path to obviate the use of long-term surface storage?
- Is an ESB by itself or in combination with additional real-time monitoring or treatment a potential solution?
- Is some combination of an environmental buffer and additional real-time monitoring or treatment a potential solution?

13.2.4 Compilation and Sharing of Advanced Water Treatment Facility Operation and Performance Data

As more potable reuse projects come online, available information covering topics such as plant design, process performance, operation practices, and mechanical reliability should be compiled in a consistent format and made accessible in a timely manner to all interested

parties. Then such data can be used to assess current practices, as well as inform and potentially promote new designs.

13.3 Future Public Outreach Needs

In the future, as more municipalities and water agencies begin to consider the potential benefits of potable reuse, documented approaches and materials will be needed to help achieve effective public outreach and increased public participation and support for DPR projects.

13.3.1 Terminology

Appropriate terminology—not technical jargon—is needed when discussing potable reuse. For example, the term “recycled water” may be viewed negatively by some members of the public, whereas “purified water” implies that the water has been treated to a high level and is viewed positively by the public (though it may not be the appropriate term for use within the engineering community). Efforts are being undertaken currently to develop consistent terminology for potable reuse within the water industry. The same is needed for the public. Accurate, understandable, and constructive terminology needs to be developed that can be used, industry-wide, when speaking with the public about potable reuse. The terminology presented in the introductory front matter of this framework document represents a useful beginning. In the future, the profession must continue to work together to develop a standard set of terminology.

13.3.2 Clear Messages about Potable Reuse

Communicating with the public about potable reuse can create mixed messages. For example, for years, the public was told “do not drink” recycled water for irrigation purposes. Now the profession is advocating potable reuse. The industry also distinguishes clearly between unplanned potable reuse (i.e., de facto reuse), IPR, and DPR, though they all are forms of potable reuse.¹⁰ These distinctions can be confusing to the public. As another example, how unregulated chemicals (e.g., CECs) and other constituents are discussed can actually prompt fear (to the public, any chemical in the water at any concentration may sound alarming). In the future, the industry needs to rethink what messages to communicate with the public to promote confidence and mitigate concerns about potable reuse.

13.4 Reference

NRC. *Water Reuse: Potential for Expanding the Nation’s Water Supply through Reuse of Municipal Wastewater*. National Research Council, National Academies Press: Washington, DC, 2012.
http://www.nap.edu/catalog.php?record_id=13303 (accessed 9/3/2015)

¹⁰ The term “potable reuse,” as used in the recent National Research Council report on *Water Reuse* (NRC, 2012), encompasses different types of projects, all with the objective of augmenting the public drinking water supply with reclaimed wastewater.

Appendix A

Summary of Epidemiology Studies and Bioanalytical Screening Studies

Table A.1. Summary of Epidemiology Studies

**Montebello Forebay Groundwater Recharge Study, Los Angeles County, CA
(Nellor et al., 1984; Sloss et al., 1996, 1999)**

Description

Recycled water has been used as a source of replenishment for groundwater since 1962; other replenishment sources are imported river water (Colorado River and State Project water) and local storm runoff. Water is percolated into the groundwater using two sets of spreading grounds.

From 1962 to 1977, the water used for replenishment was disinfected secondary effluent. Filtration (dual- or monomedia) was added later to enhance virus inactivation during final disinfection. During this period, the amount of recycled spread annually averaged 27,000 acre feet (AF), which was 16% of the inflow to the groundwater basin. At that time, an arbitrary cap of 32,700 acre feet per year (AFY) of recycled water had been established. In 1987, the project was allowed to increase the amount of recycled water to 50,000 AFY. The current permit allows for a maximum recycled water contribution of 35% based on a 5 year running average.

Studies/Results

In these studies, health outcomes were examined for 900,000 people who received some recycled water in their household water supplies in comparison to 700,000 people in a control population.

Three studies have been conducted:

- Health Effects Study (Nellor et al., 1984), which evaluated mortality, morbidity, cancer incidence, and birth outcomes for the period 1962 to 1980.
- First Rand Study (Sloss et al., 1996), which evaluated mortality, morbidity, and cancer incidence for the period 1987 to 1991.
- Second Rand Study (Sloss et al., 1999), which evaluated adverse birth outcomes for the period 1982 to 1993.

In the Health Effects Study (Nellor et al., 1984), epidemiological studies focused on a broad spectrum of health concerns that could potentially be attributed to constituents in drinking water. Health parameters evaluated included: mortality (death from all causes, heart disease, stroke, all cancers, and cancers of the colon, stomach, bladder, and rectum); cancer incidence (all cancers, and cancers of the colon, stomach, bladder, and rectum); infant and neonatal mortality; low birth weight; congenital malformations; and selected infectious diseases (including hepatitis A and shigella).

Another part of the study consisted of a telephone interview of adult females living in recycled water and control areas. Information was collected on spontaneous abortions and other adverse reproductive outcomes, bed days, disability days, and perception of well-being. The survey was able to control for the confounding factors of bottled water usage and mobility.

In the first Rand study (Sloss et al., 1996), the evaluation focused on cancer incidence (all cancers, and cancer of the bladder, colon, esophagus, kidney, liver, pancreas, rectum, stomach); mortality (death from all causes, cancer, cancer of the bladder, colon, esophagus, kidney, liver, pancreas, rectum, stomach, heart disease, cerebrovascular disease); and infectious diseases (including *Giardia*, hepatitis A, salmonella, shigella).

In the second Rand study (Sloss et al., 1999), the evaluation focused on two types of adverse birth outcomes: (a) prenatal development and infant mortality, including: low birth weight (full-term only), low birth weight (all births), very low birth weight, preterm birth, infant mortality); and (b) birth defects (all defects, neural tube defects, other nervous system defects, ears, eyes, face, neck defects; major cardiac defects, patent ductus arteriosus, other cardiac defects, and respiratory system defects; cleft defects, pyloric stenosis, intestinal arterias, other digestive system defects; limb, other musculoskeletal, integument and all other defects; chromosomal syndromes and syndromes other than chromosomal).

The results from these studies found that after almost 30 years of groundwater recharge, there was no association between recycled water and higher rates of cancer, mortality, infectious disease, or adverse birth outcomes.

Total Resource Recovery Project, City of San Diego (Cooper et al., 1992, 1997; NRC, 1998)

Description

This proposed project involved surface water augmentation with advanced treated water (ATW) to supplement the Miramar raw reservoir water (current drinking water supply). The project and treatment system are currently being reevaluated.

Studies/Results

Baseline reproductive health and vital statistics data were assembled. Reproductive data were collected from telephone interviews of 1100 women. Vital statistics data were collected on mortality, birth outcomes, and infectious disease. Data were also collected on neural tube birth defects from 1979 to 1985.

Windhoek, Namibia—Direct Reuse (Isaacson and Sayed, 1988; NRC, 1998)

Description

This project involves direct reuse. At the time the studies were conducted, the recycled water was treated using sand filtration and granular activated carbon, and the recycled water was added to drinking water supply system. The treatment system for this project has been revised since this work was conducted.

Studies/Results

The focus of this study, conducted from 1976 to 1983, was on diarrheal diseases. For the Caucasian population of similar socioeconomic status studied, disease incidence was marginally lower in persons supplied with recycled water than those with water from conventional sources. Incidence rates were significantly higher in black populations, all of whom received conventional water only. Age-specific incidence rates in children of the various ethnic groups also showed differences characteristically associated with socioeconomic stratification. It was concluded that the consumption of recycled water did not increase the risk of diarrheal diseases caused by waterborne infectious agents.

In 1998, the National Research Council committee concluded that because of limitations in the Windhoek epidemiological studies and its “unique environment and demographics, these results cannot be extrapolated to other populations in industrialized countries” (NRC, 1998).

Chanute, KS (Metzler et al., 1958)

Description

Emergency use of recycled water during a drought for 150 days from 1956 to 1957. The Neosho River was dammed below the outfall of the wastewater treatment plant, and the treated effluent backed up to the water intake. The impounding acted as waste stabilization, and water was chlorinated prior to service. The use ended when heavy rains washed out the temporary dam. The river water source already contained wastewater prior to this event.

Studies/Results

An epidemiology study showed fewer cases of stomach and intestinal illness during the period recycled water was used than during the following winter when Chanute returned to using river water.

Source: Adapted from SWRCB (2010).

References

- Cooper, R. C.; Olivieri, A. W.; Eisenberg, D. M.; Pettegrew, L.; Danielson, R. E.; Fairchild, W. A.; Sanchez, L.A. *City of San Diego Water Total Resource Recovery Project—Health Effects Study (Aqua II)*. Prepared for the City of San Diego by the Western Consortium for Public Health, Berkeley, CA, 1992.
- Cooper, R. C.; Olivieri, A. W.; Eisenberg, D. M.; Soller, J. A.; Pettegrew, L. A.; Danielson, R. E. *The City of San Diego Total Resource Recovery Project Aqua III San Pasqual Health Effects Study, Final Summary Report*. Prepared by the Western Consortium for Public Health, Berkeley, CA, 1997.
- Isaacson, M.; Sayed, A. R. Health aspects of the use of recycled water in Windhoek, SWA/Namibia, 1974–1983. Diarrhoeal Diseases and the Consumption of Reclaimed Water, *S. Afr. Med. J.* **1988**, 73 (10), 596–599.
- Metzler, D. F.; Culp, R. L.; Stoltenberg, H. A.; Woodward, R. L.; Walton, G.; Chang, S. L.; Clarke, N. A.; Palmer, C. M.; Middleton, F. M. Emergency Use of Reclaimed Water for Potable Supply at Chanute, Kansas, *J. AWWA* **1958**, 50 (8), 1021–1060.
- NRC. *Issues in Potable Reuse: The Viability of Augmenting Drinking Water Supplies with Reclaimed Water*. National Research Council, National Academies Press: Washington, DC, 1998.
http://www.nap.edu/catalog.php?record_id=13303 (accessed 9/3/2015)
- Nellor, M. H.; Baird, R. B.; Smyth, J. R. *Health Effects Study. Final Report*. County Sanitation Districts of Los Angeles County: Whittier, CA, 1984.

Sloss, E. M.; Geschwind, S. A.; McCaffrey, D. F.; Ritz, B. R. *Groundwater Recharge with Recycled Water: An Epidemiologic Assessment in Los Angeles, County, 1987–1991*. Report prepared for the Water Replenishment District of Southern California by Rand Corp., Santa Monica, CA, 1996.

Sloss, E. M.; McCaffrey, D. F.; Fricker, R. D.; Geschwind, S. A.; Ritz, B. R. *Groundwater Recharge with Recycled Water: Birth Outcomes in Los Angeles County 1982–1993*. Report prepared for the Water Replenishment District of Southern California by Rand Corp., Santa Monica, CA, 1999.

SWRCB. *Final Report: Monitoring Strategies for Chemicals of Emerging Concern (CECs) in Recycled Water—Recommendations of a Science Advisory Panel*. State Water Resources Control Board: Sacramento, CA, 2010.
http://www.waterboards.ca.gov/water_issues/programs/water_recycling_policy/docs/cec_monitoring_rpt.pdf (accessed 9/3/2015)

Table A.2. Summary of Bioanalytical Screening Studies

**Montebello Forebay Groundwater Recharge Study, Los Angeles County, CA
(Nellor et al., 1984)**

Types of Water Studied

Disinfected tertiary effluent, stormwater, and imported river water used for groundwater replenishment; also recovered groundwater

Health Effects Data

Ames *Salmonella* test and mammalian cell transformation assay. 10,000 to 20,000×organic concentrates were used in Ames test and mammalian cell assays, and subsequent chemical identification was attempted using the Ames assays. Samples were collected from the late 1970s to the early 1980s. The level of mutagenic activity (in decreasing order) was storm runoff > dry weather runoff > recycled water > groundwater > imported water. No relation was observed between percent recycled water in wells and observed mutagenicity of residues isolated from wells. The residues did not yield significant cytotoxicity in the mammalian cell assays.

To facilitate the isolation and identification of the components in sample concentrates, the residues were first fractionated by high-performance liquid chromatography, followed by testing of the fractions for mutagens and analysis of the mutagenic fractions by gas chromatography-electron ionization mass spectrometry (GC-EIMS). Results indicated that mutagenicity generally occurred in the least polar (most hydrophobic) fractions of each sample. In most cases, the sum of TA98 mutagenicity in sample fractions was similar in magnitude to that observed in the whole sample. There was no evidence of synergistic effects in these assays.

Analysis by GC-EIMS of mutagenic fractions from 34 samples yielded only four known Ames mutagens in 6 samples (fluoranthene, benzo(a)pyrene, N-nitrosomorpholine, and N-nitrosopiperidine); however, these compounds were considered to contribute little to the observed overall mutagenicity of the samples. Several unknown compounds detected in the mutagenic fractions could not have caused the mutagenicity in all of the samples, because their frequency of occurrence, distribution in the fractions, and concentrations were not consistent with the bioassay results. Selected sample residues were then evaluated qualitatively by chemical derivatization techniques to determine which classes of compounds might be contributing to the mutagenic activity.

Because mutagens are considered to be electrophilic, two nucleophilic reagents were used to selectively remove epoxide and organohalide mutagens from the residues. Analysis of mutagenic residues of groundwater and replenishment water by negative ion chemical ionization (NICI) GC-MS and Ames assay before and after derivatization supported (but did not unequivocally prove) the role of at least these two classes of electrophiles in the observed mutagenicity. Several samples had >100 reactive components, containing chlorine, bromine, iodine, or epoxides, with concentrations at the part per trillion level; however, the structures of these compounds could not be determined by NICI, nor were the sources of the compounds identified. Because positive chemical identifications of specific mutagens could not be made and the estimated concentrations of the components were so low, the biological significance of these materials remained in doubt.

Follow-up toxicity testing of recycled water residues in the mid-1990s (not published) showed no Ames test response, although preserved residues from the earlier testing still showed a response, indicating that the character of the recycled water has changed over time, perhaps as a result of increased source control activities.

**Denver Potable Water Reuse Demonstration Project
(Lauer and Rogers, 1996; NRC, 1998)**

Types of Water Studied

AWT effluent (with ultrafiltration or reverse osmosis) and finished drinking water (current supply). The purpose of the project was to evaluate the feasibility of direct reuse by producing high-quality recycled water; it was not implemented.

Health Effects Data

150 to 500 × organic residue concentrates used in a 2 year in vivo chronic/carcinogenicity study in rats and mice and reproductive/teratology study in rats. No treatment-related effects observed.

**Tampa Water Resource Recovery Project
(CH2M Hill, 1993; NRC, 1998)**

Types of Water Studied

AWT effluent [using granular activated carbon (GAC) and ozone disinfection] and Hillsborough River water using ozone disinfection (current drinking water supply). The proposed project involved augmentation of the Hillsborough River raw water supply; it was not implemented.

Health Effects Data

Up to 1000 × organic concentrates used in Ames *Salmonella*, micronucleus, and sister chromatid exchange tests in three dose levels up to 1000 × concentrates. No mutagenic activity was observed in any of the samples. In vivo testing included mouse skin initiation, Strain A mouse lung adenoma, 90 day subchronic assay on mice and rats, and a reproductive study on mice. All tests were negative, except for some fetal toxicity exhibited in rats, but not mice, for the AWT sample.

**Total Resource Recovery Project, City of San Diego
(Cooper et al., 1992, 1997; Olivieri et al., 1998; NRC, 1998)**

Types of Water Studied

ATW effluent (reverse osmosis and GAC) and Miramar raw reservoir water (current drinking water supply). This proposed surface water augmentation project would use AWT recycled water to supplement the Miramar raw reservoir water. The project and treatment system are currently being reevaluated.

Health Effects Data

150 to 600 × organic concentrates used in Ames *Salmonella* test, mouse micronucleus, 6-thioguanine resistance, and mammalian cell transformation assays. The Ames test showed some weak mutagenic activity, but recycled water was less active than drinking water. The micronucleus test showed positive results only at the high (600 ×) doses for both types of water. The 6-thioguanine assay was run on whole samples, and fractions of each type of water showed no mutagenic effect. The mammalian cell transformation assay showed a strong response for the Miramar sample, but the single test may not have been significant.

In vivo fish biomonitoring using fathead minnows (28 day bioaccumulation and swimming tests) showed no positive results. There was greater evidence of bioaccumulation of pesticides in fish.

**Potomac Estuary Experimental Wastewater Treatment Plant
(James M. Montgomery, Inc., 1983; NRC, 1998)**

Types of Water Studied

Study of the wastewater-contaminated Potomac River Estuary; 1:1 blend of estuary water and nitrified secondary effluent, AWT effluent (filtration and GAC), and finished drinking waters from three water treatment plants.

Health Effects Data

150 × organic concentrates used in Ames *Salmonella* and mammalian cell transformation tests. Results showed low levels of mutagenic activity in the Ames test, with AWT exhibiting less activity than finished drinking water. The cell transformation test showed a small number of positive samples with no difference between AWT and finished drinking water.

**Windhoek, Namibia—Direct Reuse
(NRC, 1998; du Pisani, 2005)**

Types of Water Studied

AWT effluent (sand filtration, GAC). This direct reuse project involves adding recycled water to the drinking water supply system. The treatment system has been revised since this work was conducted.

Health Effects Data

Ames test, urease enzyme activity, and bacterial growth inhibition. In vivo tests include water flea lethality and fish biomonitoring (guppy breathing rhythm).

**Singapore Water Reclamation Study
(Khan and Roser, 2007)**

Types of Water Studied

AWT effluent (microfiltration, reverse osmosis, and UV irradiation) and untreated reservoir water. The largest amount of Singapore's NEWater is currently used for industrial (semiconductor manufacturing) and commercial use. A smaller amount is blended with raw water in reservoirs, which is then treated for domestic use.

Health Effects Data

Japanese medaka fish (*Oryzias latipes*) testing over a 12 month period with two generations of fish showed no evidence of carcinogenic or estrogenic effects in AWT effluent; however, the study was repeated owing to design deficiencies.

The repeated fish study was completed in 2003 and confirmed the findings of no estrogenic or carcinogenic effects. Groups of mouse strain (B6C3F1) fed 150 × and 500 × concentrates of AWT effluent and untreated reservoir water over 2 years. The results presented to an expert panel indicated that exposure to concentrated AWT effluent did not cause any tissue abnormalities or health effects.

**Santa Ana River Water Quality Monitoring Study
(Schlenk et al., 2006)**

Types of Water Studied

Shallow groundwater adjacent to the Santa Ana River (SAR) and control water. For this unplanned potable reuse project, OCWD diverts SAR water for recharge into the Orange County Groundwater Basin. The SAR base flow is composed primarily of tertiary-treated effluent.

Health Effects Data

Three rounds of testing were conducted in 2004 and 2005. In the first two rounds, Japanese medaka fish were analyzed for tissue pathology, vitellogenin induction, reproduction, and gross morphology. In the third round, fish were analyzed for vitellogenin induction, reproduction, limited tissue pathology, and gross morphology.

In the first two rounds, no statistically significant differences in gross morphological endpoints, gender ratios, tissue pathology, or reproduction were observed between the test water (shallow groundwater adjacent to the SAR) and the control water. In the third round, no statistically significant differences were observed in reproduction, tissue pathology (limited to evaluation of gonads and ovaries), or vitellogenin induction between the test water and the control water.

Soil Aquifer Treatment Study (Fox et al., 2006)

Types of Water Studied

Wastewater (various facilities), soil aquifer treatment water, stormwater.

Health Effects Data

The study used a variety of analytical methods to characterize and measure chemical estrogenicity: in vitro methods (estrogen binding assay, glucocorticoid receptor competitive binding assay, yeast-based reporter gene assay, and MCF-7 cell proliferation assay); in vivo fish vitellogenin synthesis assay; enzyme-linked immunosorbent assays (ELISAs); and GC-MS.

Procedures were developed to extract estrogenic compounds from solids, liquid/liquid methods for direct extraction from aqueous suspensions such as primary and secondary effluents, and concentration of estrogenic (and other) organics on hydrophobic resins followed by organic fractionation during elution in a solvent (alcohol/water) gradient. Field applications of these techniques were designed to measure estrogenic activity derived from conventional wastewater treatment and soil-aquifer treatment (SAT). The stability of estrogenic contaminants removed by soils in the SAT treatment system was investigated by extracting and measuring nonylphenol from infiltration basin soils, as well as by measuring total estrogenic activity in soil extracts.

The researchers attempted to separate and measure estrogenic and antiestrogenic activities in wastewater effluent and conducted a multilaboratory experiment in which a variety of wastewater effluents and effluents spiked with known concentrations of specific estrogenic chemicals were tested for estrogenic activity. Significant variability in recycled water estrogenicity was observed in bioassay results. Facilities with the longest hydraulic retention times tended to have the lowest observed levels of estrogenicity. Estrogenicity was efficiently removed during SAT. The study also presented information on the advantages and disadvantages of the bioassay test procedures evaluated.

Toxicological Relevance of Endocrine-Disrupting Compounds and Pharmaceuticals in Drinking Water (Snyder et al., 2007, 2008a, 2008b)

Types of Water Studied

Drinking water (20 facilities), wastewater (4 facilities: raw and recycled), and food products.

Health Effects Data

The researchers used an in vitro cellular bioassay (E-screen) with a method reporting limit (MRL) of 0.16 ng/L; results were also converted to estradiol equivalents. The results showed that the vast majority of drinking waters were less than the MRL. The level of estrogenicity (in decreasing order) was food and beverage products (particularly soy-based products) > raw wastewater > recycled water > finished drinking water.

Source: Adapted from SWRCB (2010).

References

- CH2M Hill. *Tampa Water Resource Recovery Project Pilot Studies*, CH2M Hill: Tampa, FL, 1993.
- Cooper, R. C.; Olivieri, A. W.; Eisenberg, D. M.; Pettegrew, L.; Danielson, R. E.; Fairchild, W. A.; Sanchez, L.A. *City of San Diego Water Total Resource Recovery Project—Health Effects Study (Aqua II)*. Prepared for the City of San Diego by the Western Consortium for Public Health, Berkeley, CA, 1992.
- Cooper, R. C.; Olivieri, A. W.; Eisenberg, D. M.; Soller, J. A.; Pettegrew, L. A.; Danielson, R. E. *The City of San Diego Total Resource Recovery Project Aqua III San Pasqual Health Effects Study, Final Summary Report*. Prepared by the Western Consortium for Public Health, Berkeley, CA, 1997.
- du Pisani, P. L. Direct Reclamation of Potable Water at Windhoek's Goreangab Reclamation Plant. In Khan, S. J.; Schäfer, A. I.; Muston, M. H., eds.; *Integrated Concepts in Water Recycling*. University of Wollongong: New South Wales, Australia, 2005, pp 193–202.
- Fox, P.; Houston, S.; Westerhoff, P.; Nellor, M.; Yanko, W.; Baird, R.; Rincon, M.; Gully, J.; Carr, S.; Arnold, R.; Lansey, K.; Quanrud, D.; Ela, W.; Amy, G.; Reinhard, M.; Drewes, J. E. A. *Advances in Soil-Aquifer Treatment for Sustainable Reuse*. American Water Works Association Research Foundation: Denver, CO, 2006.
- James M. Montgomery, Inc. *Operation, Maintenance, and Performance Evaluation of the Potomac Estuary Wastewater Treatment Plant*. Montgomery Watson, Inc.: Alexandria, VA, 1983.
- Khan, S.; Roser, D. *Risk Assessment and Health Effects Studies of Indirect Potable Reuse Schemes. Final Report*, CWWT Report 2007/08. Centre for Water and Waste Technology, School of Civil and Environmental Engineering, University of New South Wales: Sydney, Australia, 2007.

- Lauer, W. C.; Rogers, S. E. The Demonstration of Direct Potable Reuse: Denver's Pioneer Project. In *Proceedings AWWA/WEF 1996 Water Reuse Conference*, American Water Works Association, Denver, CO, 1996, pp 269–289.
- National Research Council (NRC). *Issues in Potable Reuse: The Viability of Augmenting Drinking Water Supplies with Reclaimed Water*. National Academies Press: Washington, DC, 1998.
- Nellor, M. H.; Baird, R. B.; Smyth, J. R. *Health Effects Study. Final Report*. County Sanitation Districts of Los Angeles County, Whittier, CA, 1984.
- Olivieri, A. W.; Eisenberg, D. M.; Cooper, R. C. City of San Diego Health Effects Study of Potable Water Reuse. In Asano, T., ed.; *Wastewater Reclamation and Reuse*. Technomic Publishing: Ann Arbor, MI, 1998, pp 521–580.
- Schlenk, D.; Hinton, D. E.; Woodside, G. *Online Methods for Evaluating the Safety of Reclaimed Water*. Water Environment Research Foundation: Alexandria, VA, 2006.
- Snyder, S. A.; Wert, E. C.; Hongxia, L.; Westerhoff, P.; Yoon, Y. *Removal of EDCs and Pharmaceuticals in Drinking and Reuse Treatment Processes*. American Water Works Association Research Foundation: Denver, CO, 2007.
- Snyder, S. A.; Trenholm, R. A.; Snyder, E. M.; Bruce, G. M.; Pleus, R. C.; Hemming, J. D. C. *Toxicological Relevance of EDCs and Pharmaceuticals in Drinking Water*. American Water Works Association Research Foundation: Denver, CO, 2008a.
- Snyder, S. A.; Vanderford, B. J.; Drewes, J. E.; Dickenson, E.; Snyder, E. M.; Bruce, G. M.; Pleus, R. C. *State of Knowledge of Endocrine Disruptors and Pharmaceuticals in Drinking Water*. American Water Works Association Research Foundation: Denver, CO, 2008b.
- SWRCB. *Final Report: Monitoring Strategies for Chemicals of Emerging Concern (CECs) in Recycled Water—Recommendations of a Science Advisory Panel*. State Water Resources Control Board: Sacramento, CA, 2010.
http://www.waterboards.ca.gov/water_issues/programs/water_recycling_policy/docs/cec_monitoring_rpt.pdf (accessed 9/3/2015)

Appendix B

Summary of Example Representative Quantitative Relative Risk Assessments

Quantitative relative risk assessments (QRRAs) differ from conventional risk assessments in that doses are calculated based on observed concentrations in water and an *assumed* standard water intake in lieu of deriving a site-specific water intake rate (because determinations of absolute exposure in terms of the amount of water consumed in a study population cannot be derived reliably or easily). For example, absolute exposure is impacted by the use of bottled water, consuming different water at home rather than at work, and population mobility; therefore, a QRRRA does not assess the absolute risk from ingestion of water at the tap, but rather compares the relative risk of the scenario being evaluated assuming everyone is drinking the same amount of water at the same concentration. This approach is more conservative than using absolute exposure information. Examples include:

- QRRAs were conducted as part of the **City of San Diego Health Effects** investigations (Cooper et al., 1992, 1997) to compare the potential health risk of consuming the existing drinking water supply (i.e., untreated raw potable water) with consuming advanced treated water (ATW) from two separate advanced treated water facilities (AWTFs) (assuming ATW served as a raw water source without any additional surface water treatment). The QRRRA was performed using the U.S. Environmental Protection Agency (U.S. EPA) hazard index (HI) method (i.e., reference dose approach) for noncarcinogenic effects and the U.S. EPA cancer potency unit risk values for carcinogens.

The overall results indicated that the estimated HIs are well below 1, indicating that a significant public health risk would not be anticipated. The carcinogenic risk estimates indicated that the ATW was two orders of magnitude less than the current raw water supply and estimated at less than 1 excess cancer per million people.

- QRRAs were conducted for the **Montebello Forebay and Chino Basin groundwater recharge projects** (Soller and Nellor, 2011a, 2011b). Recycled water used for these projects meets the California Water Recycling Criteria standard for disinfected filtered recycled water and federal and state drinking water maximum contaminant levels (MCLs) in recycled water before or after surface application. Both these projects apply recycled water using spreading basins. For both groundwater replenishment projects, results showed it was unlikely that recycled water used for groundwater replenishment contributed substantially to human health risk. Naturally occurring arsenic (i.e., not impacted by recycled water used for groundwater replenishment) was the highest contributor to risk in groundwater.
- The **Orange County Water District (OCWD)** in California conducted a QRRRA to compare alternative water sources used to replenish the Orange County Groundwater Basin (EOA, Inc., 2000). The alternatives considered were Santa Ana River water (which includes a substantial contribution of wastewater from upstream dischargers), Colorado River water (which also includes a substantial contribution of wastewater from upstream dischargers), California State Water Project water, and advanced treated recycled water.

The results showed that the ATW was projected to present much less risk than the other waters from bacteria, parasites, and viruses, provided that all unit treatment processes in the AWWTF were fully operational and operating properly.

- QRRAs have also been conducted for **two direct potable reuse (DPR) case studies in Texas** (APAI, 2015). Each case study compared a No Project Alternative (i.e., raw surface water that has undergone drinking water treatment) with a potential DPR Alternative (i.e., treated wastewater that has undergone advanced water treatment and drinking water treatment). For water treatment, one case study used conventional treatment, and one used additional treatment processes that addressed taste and odor, iron and manganese, and the need to reduce disinfection byproduct (DBP) formation. For advanced water treatment, one case study used reverse osmosis (RO) and one did not, reflecting interest in evaluating treatment schemes that do not generate RO concentrate.

For each No Project Alternative and DPR Alternative, the cumulative HI was less than 1; however, the cumulative health hazard for the DPR non-RO advanced water treatment was close to 1, primarily coming from nitrate and fluoride that met standards, illustrating the role of RO membranes in removing salts and supportive of better removal of nitrogen at the wastewater treatment plant. The calculated hypothetical carcinogenic risk for the DPR RO advanced water treatment was about an order of magnitude lower than the No Project Alternatives and the DPR non-RO advanced water treatment. For each alternative, arsenic and DBPs were major contributors to risk. These results highlight the need to consider the prevention of DBP formation or removal of DBPs as part of a DPR treatment scheme.

References

- APAI. *Final Report: Direct Potable Reuse Resource Document*. Report prepared for the Texas Water Development Board by Alan Plummer Associates, Inc.: Fort Worth, TX, 2015.
http://www.twdb.texas.gov/publications/reports/contracted_reports/doc/1248321508_Vol1.pdf (accessed 9/3/2015)
http://www.twdb.texas.gov/publications/reports/contracted_reports/doc/1248321508_Vol2.pdf (accessed 9/3/2015)
- Cooper, R. C.; Olivieri, A. W.; Eisenberg, D. M.; Pettegrew, L.; Danielson, R. E.; Fairchild, W. A.; Sanchez, L.A. *City of San Diego Water Total Resource Recovery Project—Health Effects Study (Aqua II)*. Prepared for the City of San Diego by the Western Consortium for Public Health, Berkeley, CA, 1992.
- Cooper, R. C.; Olivieri, A. W.; Eisenberg, D. M.; Soller, J. A.; Pettegrew, L. A.; Danielson, R. E. *The City of San Diego Total Resource Recovery Project Aqua III San Pasqual Health Effects Study, Final Summary Report*. Prepared by the Western Consortium for Public Health, Berkeley, CA, 1997.
- EOA, Inc. *Groundwater Replenishment System Water Quality Evaluation*. Orange County Water District and Orange County Sanitation District, Fountain Valley, CA, 2000.
- Soller, J. A.; Nellor, M. H. *Development and Application of Tools to Assess and Understand the Relative Risks of Regulated Chemicals in Indirect Potable Reuse Projects Task 1—The Montebello Forebay Groundwater Recharge Project*. WateReuse Research Foundation: Alexandria, VA, 2011a.

Soller, J. A.; Nellor, M. H. *Development and Application of Tools to Assess and Understand the Relative Risks of Regulated Chemicals in Indirect Potable Reuse Projects Task 1—The Chino Basin Groundwater Recharge Project*. WateReuse Research Foundation: Alexandria, VA, 2011b.

Appendix C

Recommended Constituents of Emerging Concern to Be Considered in Direct Potable Reuse Projects

The following tables, which recommended constituents of emerging concern (CECs) to consider for DPR projects, were published in NWRI (2013).

Table C.1. Nonregulated Chemicals of Interest from the Standpoint of Public Health (If Present in Wastewater)

Chemicals	Criterion (if applicable)	Rationale	Source
Perfluorooctanoic acid	0.4 µg/L	Known to occur, frequency unknown	Provisional short-term U.S. EPA Health Advisory
Perfluorooctane sulfonate	0.2 µg/L	Known to occur, frequency unknown	Provisional short-term U.S. EPA Health Advisory
Perchlorate	15 µg/L, 6 µg/L	Of interest, same analysis as chlorate and bromate	U.S. EPA Health Advisory, California Maximum Contaminant Level
1,4-Dioxane	1 µg/L	Occurs at a relatively low frequency in wastewater, but likely to penetrate reverse osmosis membranes	Division of Drinking Water, California State Water Resources Control Board notification level
Steroid Hormones			
Ethinyl estradiol	None, but if established, it will approach the detection limit (low ng/L).	Should evaluate its presence in source water	Bull et al. (2011)
17-β-estradiol	None, but if established, it will approach the detection limit (low ng/L).	Should evaluate its presence in source water	Bull et al. (2011)

Table C.2. Chemicals that Should Be Useful for Evaluating the Effectiveness of Organic Chemical Removal by Treatment Trains

Pharmaceuticals ^a	Criterion ^b (if applicable)	Rationale	Source
Cotinine, Primidone, Phenytoin	1 µg/L, 10 µg/L, 2 µg/L	Surrogate for low molecular weight; partially charged cyclics	Bruce et al. (2010) Bull et al. (2011)
Meprobamate, Atenolol	200 µg/L, 4 µg/L	Occur frequently at ng level	Bull et al. (2011)
Carbamazepine	10 µg/L	Unique structure	Bruce et al. (2010)
Estrone	320 ng/L	Surrogate for steroids	Based on an increased risk of stroke and deep vein thrombosis in women taking the lowest dose (0.625 mg/day) of conjugated estrogens/1000 ^a
Other Chemicals			
Sucralose	150 mg/L ^c	Surrogate for water soluble, uncharged chemicals, moderate molecular weight	CFR Title 12, revised 4/1/12
Tris (2-Carboxyethyl) phosphine) hydrochloride	5 µg/L	Chemical of interest	Minnesota Department of Health guidance value (MDH, 2015)
N,N-diethyl-meta-toluamide	200 µg/L	Common constituent in highly treated wastewaters	Minnesota Department of Health guidance value (MDH, 2015)
Triclosan	2100 µg/L	Chemical of interest	Risk-based action level (NRC, 2012)

Notes: ^aConjugated estrogens (largely estrone conjugates) administered without progestin increased significantly the risk of deep vein thrombosis and stroke in a large clinical study of postmenopausal women conducted over 5.1 years (it involved groups of >5000 treated and 5000 placebo subjects). Cited in RxList (2012). ^bIn the case of pharmaceuticals, the criterion is given as the drinking water equivalent concentration for the lowest therapeutic dose/1000. In the case of the anticonvulsant drugs, the lowest daily maintenance dose in adults/10,000 was used in recognition of the teratogenic potential of these drugs (Primidone); however, the numbers for carbamazepine and phenytoin are based on reported carcinogenicity. ^cSucralose is based upon an acceptable daily intake established by the U.S. Food and Drug Administration of 5 mg/kg per day×60 kg/2 L.

References

- Bruce, G. M.; Pleus, R. C.; Snyder, S. A. Toxicological Relevance of Pharmaceuticals in Drinking Water. *Environ. Sci. Technol.* **2010**, *44*, 5619–5626.
- Bull, R.; Crook, J.; Whittaker, M.; Cotruvo, J. Therapeutic Dose as the Point of Departure in Assessing Potential Health Hazards from Drugs in Recycled Municipal Wastewater. *Regul. Toxicol. Pharm.* **2011**, *60* (1), 1–19.
- MDH. *Human Health-Based Water Guidance Table*, webpage last updated by the Minnesota Department of Health on September 1, 2015.
<http://www.health.state.mn.us/divs/eh/risk/guidance/gw/table.html> (accessed 9/3/2015)
- NRC. *Water Reuse: Potential for Expanding the Nation's Water Supply through Reuse of Municipal Wastewater*. National Research Council, National Academies Press: Washington, DC, 2012.
http://www.nap.edu/catalog.php?record_id=13303 (accessed 9/3/2015)
- NWRI. *Examining the Criteria for Direct Potable Reuse*. Independent Advisory Panel Final Report prepared for Trussell Technologies, Inc., under WateReuse Research Foundation Project No. 11-02, National Water Research Institute: Fountain Valley, CA, 2013.
<https://www.watereuse.org/product/11-02-1> (accessed 9/3/2015)
- RxList. Prempro, Premphase, website last reviewed by the RxList on February 21, 2012.
<http://www.rxlist.com/prempro-drug/clinical-pharmacology.htm#CS> (accessed 9/3/2015)

Appendix D

Federal Pretreatment Program Prohibitions

A publicly owned treatment works (POTW) must enforce general and specific prohibitions that apply to all nondomestic users. The general prohibitions disallow a user from discharging pollutants that cause pass-through or interference, as specified in the Code of Federal Regulations [40 CFR §403.5(a)]. The specific discharge prohibitions listed in 40 CFR §403.5(b) exclude the discharge of the following:

- Pollutants that may create a fire or explosion hazard in the sewer system or at the POTW
- Corrosive pollutants, including any discharge with a pH of less than 5
- Solid or viscous pollutants in sufficient amounts that will cause obstruction or blockage of flow
- Any pollutants discharged in sufficient quantity to interfere with the operation of the POTW
- Heat in such quantities that the temperature at the POTW treatment plant exceeds 104°F or is hot enough to interfere with biological treatment processes
- Petroleum oil, non-biodegradable cutting oil, or other products of mineral oil origin in amounts sufficient to cause interference or pass-through
- Pollutants that result in the presence of toxic gases, vapors, or fumes at the POTW in sufficient amounts to cause acute worker health and safety problems
- Any trucked or hauled pollutants, except at discharge points designated by the POTW

Appendix E

Federal Pretreatment Program—Categorical Pretreatment Standards

Categorical pretreatment standards are technology-based numeric limits that have been developed in accordance with Section 307 of the Clean Water Act to limit pollutant discharges to publicly owned treatment works (POTWs) from specific process wastewaters from industrial users (IUs). These national technology-based standards apply to an IU regardless of whether the POTW has an approved pretreatment program or the IU has been issued a control mechanism or permit. The standards are established based on the list of priority pollutants in 40 CFR §401.15, which contains 65 entries (some being groups of pollutants). The list of industrial categories and applicable federal regulations are shown in Table E.1.

Table E.1. U.S. EPA Pretreatment Categories and Standards

Category ^a	40 CFR §	Category	40 CFR §
Aluminum forming	467	Battery manufacturing	461
Carbon black manufacturing (new sources only)	458	Centralized waste treatment	437
Coil coating	465	Copper forming	468
Electrical and electronic components	469	Electroplating	413
Feedlots (new sources only) ^b	412	Fertilizer manufacturing (new sources only)	418
Glass manufacturing (new sources only)	426	Grain mills (new sources only)	406
Ink formulating (new sources only)	447	Inorganic chemicals manufacturing	415
Iron and steel	420	Leather tanning and finishing	425
Metal finishing	433	Metal molding and casting	464
Nonferrous metals forming	471	Nonferrous metal manufacturing	421
Oil and gas extraction	435	Organic chemicals, plastics, and synthetic fibers	414
Paint formulating (new sources only)	446	Paving and roofing (new sources only)	443
Petroleum refining	419	Pesticide chemicals manufacturing	455
Pharmaceuticals	439	Porcelain enameling	466

Category ^a	40 CFR §	Category	40 CFR §
Pulp, paper, and paperboard	430	Rubber manufacturing (new sources only)	428
Soap and detergent manufacturing (new sources only)	417	Steam electric	423
Timber products	429	Transportation equipment cleaning	442
Waste combustors	444		

Notes: ^aU.S. EPA is proposing technology-based pretreatment standards for dental practices that would require dentists to control discharges of dental amalgam and amendments to 40 CFR §403 to streamline oversight requirements for the dental sector. See U.S. EPA (2015).

^bA new source is any building, structure, facility, or installation from which there is a discharge that started after the publication of the proposed pretreatment standards (more detail is provided in 40 CFR §403.3).

Source: TCEQ (2015).

Categorical industrial users (CIUs) subject to these regulations must comply with monitoring, reporting, and record keeping requirements in the applicable regulations (as well as local requirements levied by the POTW).

A POTW can calculate an equivalent mass limit for an IU's permit (or control mechanism) for those categorical pretreatment standards that are expressed in terms of concentration. Once in the permit, the equivalent limit replaces the promulgated concentration-based pretreatment standard.

References

TCEQ. EPA Pretreatment Categories and Standards, webpage last updated by the Texas Commission on Environmental Quality on March, 2015.
http://www.tceq.texas.gov/permitting/wastewater/pretreatment/EPA_categories_standards.html (accessed 9/3/2015)

U.S. EPA. Dental Effluent Guidelines, webpage last updated by the U.S. Environmental Protection Agency on February, 2015.
<http://water.epa.gov/scitech/wastetech/guide/dental/> (accessed 9/3/2015)

Appendix F

Example Source Control Programs

1. Orange County Sanitation District's Source Control Program

The Orange County Sanitation District (OCSD), which has a service area of 479 mi² with over more than 2.5-million residents, provides secondary effluent for the Groundwater Replenishment System (GWRS), the largest indirect potable reuse (IPR) plant in the world. OCSD's Expanded Source Control Program protects the water quality of GWRS by reducing or preventing pollutants from entering wastewater.

Features of the Source Control Program include:

- **Pollutant identification**—OCSD works with the U.S. Environmental Protection Agency (U.S. EPA), State Water Resources Control Board, Regional Water Quality Control Board, and Orange County Health Care Agency to screen pollutants in the environment and assess their impacts to determine if they are pollutants of concern.
- **Countywide mass balance**—OCSD uses a countywide mass balance and geographic information system, which is essentially an accounting sheet to track the locations where specific constituents are being discharged and in what amounts. This program has been used successfully to trace constituents back to the source. For example, 50 lb/day of a pollutant was traced from the headworks—through a 155 mi² area—back to the individual discharge sources.
- **Chemical Inventory Program**—OCSD monitors the inventories of stored chemicals in Orange County as part of a broader program by the U.S. EPA. This inventory helps to quickly locate chemical sources in its service area. The program will be supplemented by a web portal live database system called E-Submit maintained by Orange County Environmental Health.
- **Chemical data sheets**—OCSD maintains a list of chemical data sheets that profile chemicals, their properties, and effects in the environment. The list is developed from chemicals detected in the influent to the treatment systems and regulated constituents purposed to support staff investigations and studies.
- **Pollutant Prevention Program**—This program features the following industrial/commercial and residential components:
 - **Industrial/commercial:** As part of a pollutant response plan, OCSD works with industries and commercial businesses to determine the best means to prevent pollutants from being discharged to the sewer through wastewater treatment technologies or administrative measures.

- Residential: OCSD also uses public outreach such as the “What-to-Flush” and “No Drugs Down the Drain” campaigns to inform residents that the toilet is only meant to flush the three “Ps”: pee, poop, and paper. OCSD also uses a Countywide Pollution Prevention Partnership program to leverage established government multimedia outlets to disseminate information to the public.

OCSD is also participating in research programs with association partners on real-time monitoring devices and integrating data feeds at critical control points with the expanded program for a prudent response.

2. Oregon Priority Persistent Pollutants

Oregon has developed a program that requires publicly owned treatment works (POTWs) to develop toxics reduction plans for priority persistent pollutants (DEQ, no date). In 2007, the Oregon Legislature passed Senate Bill (SB) 737, which required the Oregon Department of Environmental Quality (DEQ) to consult with all interested parties by June 1, 2009, to develop a list of priority persistent pollutants (the “P3 list”) that have a documented effect on human health, wildlife, or aquatic life. By June 1, 2010, DEQ was required to issue a final report to the legislature about the sources of priority persistent pollutants “from existing data” and identify source reduction and control methods that can reduce discharges. SB 737 also required Oregon’s 52 largest municipal wastewater treatment plants (WWTPs) to develop plans by July 1, 2011, for reducing priority persistent pollutants through pollution prevention and toxics reduction. The municipalities or districts were required to develop toxics reduction plans for any of the pollutants on the P3 list that are present in treatment plant discharges at levels greater than maximum contaminant levels (MCLs) or an initiation level established by DEQ. The P3 list was derived with input from expert work groups.

The P3 list is made up of pesticides, industrial chemicals, polyaromatic hydrocarbons, metals, and perfluorinated surfactants. Of the 118 listed pollutants, 33 have established MCLs; the remaining pollutants have a DEQ initiation level (DEQ, 2011). An initiation level is the concentration of a pollutant in municipal WWTP effluent that, if exceeded, triggers the need for a “persistent pollutant reduction plan” for that pollutant. DEQ developed an implementation plan (i.e., sampling and quality assurance/quality control) to assist municipalities in preparing reduction plans (DEQ, 2010).

During the regulatory adoption process, some stakeholders expressed concern that although initiation levels are not water quality standards, they may be used as such. SB 737 specifically precludes the use of initiation levels as water quality standards [Section 4(1)(b)], and DEQ has repeated in the regulation the language from SB 737 stating that initiation levels are not water quality standards under state or federal law.

Sampling conducted in 2010 showed that municipal WWTPs routinely exceed initiation levels for cholesterol and coprostanol, two naturally occurring human digestion byproducts (and, therefore, pollutants with no feasible municipal pollution prevention activities or cost-effective treatment options). In 2011, DEQ adopted a rule so the wastewater agencies would not have to develop reduction plans for cholesterol and coprostanol.

3. References

- DEQ. Senate Bill 737 Implementation: Addressing Priority Persistent Pollutants in Oregon's Water. Webpage of the Oregon Department of Environmental Quality, not dated.
<http://www.deq.state.or.us/wq/SB737/> (accessed 9/3/2015)
- DEQ. Department of Environmental Quality Division 045 Regulations Pertaining to NPDES and WPCF Permits. Oregon Department of Environmental Quality: Portland, OR, Oct. 20-21, 2011.
<http://www.deq.state.or.us/about/eqc/agendas/attachments/2011oct/G-Att-Div045.pdf>
(accessed 9/3/2015)
- DEQ. *Quality Assurance Project Plan FINAL: SB 737 Implementation*. Oregon Department of Environmental Quality: Portland, OR, July, 2010.
<http://www.deq.state.or.us/wq/SB737/docs/QAPPf.pdf> (accessed 9/3/2015)

Appendix G

National Primary and Secondary Drinking Water Standards for Chemicals

The United States Environmental Protection Agency (U.S. EPA) Drinking Water Standards and Health Advisories are available online by searching EPA 822-S-12-001. Tables G.1 to G.6 can be found in the U.S. EPA's 2012 Edition of the *Drinking Water Standards and Health Advisories*.

Table G.1. Inorganics with Primary MCLs

Constituents	Primary MCL (mg/L)	Constituents	Primary MCL (mg/L)
Antimony	0.006	Fluoride	4
Arsenic	0.010	Lead	0.015 ^c
Asbestos	7 (MFL) ^a	Mercury	0.002
Barium	2	Nitrate (as N)	10
Beryllium	0.004	Nitrite (as N)	1
Cadmium	0.005	Total nitrate/nitrite (as N)	10
Total chromium	0.1	Selenium	0.05
Copper	1.3 ^b	Thallium	0.002
Cyanide	0.2		

Notes: ^aMFL=million fibers per liter, with fiber lengths of >10 microns.

^bRegulatory Action Level; if system exceeds, it must take certain actions, such as additional monitoring, corrosion control studies and treatment, and, for lead, a public education program; replaces MCL. ^cThe MCL for lead was rescinded with the adoption of the Regulatory Action Level. MCL=maximum contaminant level; mg/L=milligram per liter.

Table G.2. Constituents/Parameters with Secondary MCLs

Constituents	MCL (mg/L)	Constituents	MCL (mg/L)
Aluminum	0.2	TDS	500
Color	15 (units)	Fluoride	2.0
Copper	1.0	Chloride	250
Foaming agents (e.g., MBAS)	0.5	Sulfate	250
Iron	0.3	pH	6.5–8.5
Manganese	0.05	Silver	0.1
Odor threshold	3 (units)	Zinc	5

Notes: MBAS= methylene blue active substances; MCL=maximum contaminant level; mg/L=milligram per liter; TDS=total dissolved solids.

Table G.3. Radioactivity

Constituent	MCL	Constituent	MCL
Uranium	0.030 mg/L	Gross beta particle activity	4 mrem/year
Combined radium-226 and 228	5 pCi/L	Radon	300 pCi/L
Gross alpha particle activity	15 pCi/L		

Notes: MCL=maximum contaminant level; mg/L=milligram per liter; mrem=millirem; pCi/L=picocuries per liter.

Table G.4. Regulated Organics

Constituent	MCL (mg/L)	Constituent	MCL (mg/L)
Volatile Organic Compounds			
Benzene	0.005	Monochlorobenzene	0.1
Carbon tetrachloride	0.005	Styrene	0.1
1,2-Dichlorobenzene	0.6	1,1,2,2-Tetrachloroethane	0.001
1,4-Dichlorobenzene	0.075	Tetrachloroethylene	0.005
1,1-Dichloroethane	0.005	Toluene	1
1,2-Dichloroethane	0.005	1,2,4 Trichlorobenzene	0.07
1,1-Dichloroethylene	0.007	1,1,1-Trichloroethane	0.2
Cis-1,2-Dichloroethylene	0.07	1,1,2-Trichloroethane	0.005
Trans-1,2-Dichloroethylene	0.1	Trichloroethylene	0.005
Dichloromethane	0.005	Vinyl chloride	0.002
1,2-Dichloropropane	0.005	Xylenes	10
Ethylbenzene	0.7		
Semivolatile Organic Compounds			
Alachlor	0.002	Heptachlor epoxide	0.0002
Atrazine	0.003	Hexachlorobenzene	0.001
Bentazon	0.018	Hexachlorocyclopentadiene	0.05
Benzo(a)pyrene	0.0002	Lindane	0.0002
Carbofuran	0.04	Methoxychlor	0.04
Chlordane	0.002	Molinate	0.02
Dalapon	0.2	Oxamyl	0.2
Dibromochloropropane	0.0002	Pentachlorophenol	0.001
Di(2-ethylhexyl)adipate	0.4	Picloram	0.5
Di(2-ethylhexyl)phthalate	0.006	Polychlorinated biphenyls	0.0005
2,4-D (2,4-dichlorophenoxyacetic acid)	0.07	Pentachlorophenol	0.001

Constituent	MCL (mg/L)	Constituent	MCL (mg/L)
Dinoseb	0.007	Picloram	0.5
Diquat	0.03	Polychlorinated biphenyls	0.0005
Endothall	0.1	Simazine	0.004
Endrin	0.002	Toxaphene	0.003
Ethylene dibromide	0.00005	2,3,7,8-TCDD (Dioxin)	3 x 10 ⁻⁸
Glyphosate	0.7	2,4,5-TP (Silvex)	0.05
Heptachlor	0.0004		

Note: MCL=maximum contaminant level; mg/L=milligram per liter.

Table G.5. Disinfection Byproducts

Constituent	MCL (mg/L)	Constituent	MCL (mg/L)
Total trihalomethanes	0.080	Bromate	0.010
Total haloacetic acids	0.060	Chlorite	1.0

Notes: MCL=maximum contaminant level; mg/L=milligram per liter.

Table G.6. Disinfectants

Constituent	MCL (mg/L)
Chlorine	4
Chlorine dioxide	0.8
Chloramine	4

Notes: MCL=maximum contaminant level; mg/L=milligram per liter.

Appendix H

Biographies of the Independent Advisory Panel Members and Editors

1. Independent Advisory Panel

Chair: George Tchobanoglous, PhD, PE, NAE, BCEE. For more than 35 years, wastewater expert George Tchobanoglous taught courses on water and wastewater treatment and solid waste management at the University of California, Davis, where he is Professor Emeritus in the Department of Civil and Environmental Engineering. He has authored or coauthored more than 550 publications, including 23 textbooks and eight engineering reference books. Along with coauthors, he has written extensively on water reuse, including the textbook *Water Reuse: Issues, Technologies, and Applications*; the WateReuse report *Direct Potable Reuse: A Path Forward*; and the National Water Research Institute (NWRI) White Paper on *Direct Potable Reuse: Benefits for Public Water Supplies, Agriculture, the Environment, and Energy Conservation*. He has also given more than 550 presentations on a variety of environmental engineering subjects. Tchobanoglous has been president of the Association of Environmental Engineering and Science Professors (AEESP). He received the Athalie Richardson Irvine Clarke Prize from NWRI in 2003, was inducted to the National Academy of Engineers in 2004, and received an Honorary Doctor of Engineering degree from the Colorado School of Mines in 2005. In 2012, he received the first Excellence in Engineering Education Award from the American Academy of Environmental Engineers (AAEE) and AEESP. In 2013, he was selected as the AAEE and AEESP Kappe Lecturer. Tchobanoglous received a BS in Civil Engineering from the University of the Pacific, an MS in Sanitary Engineering from the University of California, Berkeley, and a PhD in Environmental Engineering from Stanford University.

Joseph A. Cotruvo, PhD, BCES. Joe Cotruvo is president of Joseph Cotruvo & Associates, an environmental and public health consulting firm in Washington, DC, and active in the World Health Organization (WHO)/National Science Foundation (NSF) International Collaborating Centre for Drinking Water Safety and Treatment. Previously, he served as director of the Criteria and Standards Division of the US Environmental Protection Agency (EPA) Office of Drinking Water, where his organization developed the Drinking Water Health Advisory System and numerous National Drinking Water-Quality Standards and Guidelines. He was also director of the EPA's Risk Assessment Division and a former vice president for Environmental Health Sciences at NSF International. He is a member of WHO Drinking Water Guidelines development committees, and he has led the recently published monograph *Desalination Technology: Health and Environmental Impacts*. He also led studies on bromate metabolism through the American Water Works Association Research Foundation and recycled water contaminants for the WateReuse Foundation. He was chairman of the Water Quality and Water Services Committee of the Board of Directors of the District of Columbia Water and Sewer Authority. He is also chair of the WateReuse Association National Regulatory Committee. He received a BS in Chemistry from the University of Toledo and a PhD in Physical Organic Chemistry from Ohio State University.

James Crook, PhD, PE, BCEE. Jim Crook is an environmental engineering consultant (Boston, MA) with more than 40 years of experience in state government and consulting engineering arenas, serving public and private sectors in the United States and abroad. He has authored more than 100 publications and is an internationally recognized expert in water reclamation and reuse. He has been involved in numerous projects and research activities involving public health, regulations and permitting, water quality, risk assessment, treatment technology, and water reuse. Crook spent 15 years directing the California Department of Health Services water reuse program, during which time he developed California's first comprehensive water reuse criteria. He also spent 15 years with consulting firms overseeing water reuse activities and is now an independent consultant specializing in water reuse. He currently serves on a number of advisory panels and committees, including serving as co-chair of an NWRI Expert Panel for the state of California on developing water recycling criteria for indirect potable reuse through surface water augmentation and determining the feasibility of developing criteria for direct potable reuse. He was elected as a Water Environment Federation Fellow in 2014 and selected as the AAEE 2002 Kappe Lecturer and the WaterReuse Association's 2005 Person of the Year. Crook received a BS in Civil Engineering from the University of Massachusetts and both an MS and PhD in Environmental Engineering from the University of Cincinnati.

Ellen McDonald, PhD, PE. Ellen McDonald is a principal at Alan Plummer Associates, where she leads the water resources group. She has more than 20 years of experience in the areas of water resources planning, water reuse, water quality modeling, and water and wastewater system modeling and planning. Through her work at Alan Plummer Associates, she has assisted a number of Texas cities and water districts in the development and implementation of water reuse projects relating to both direct and indirect potable reuse. For example, she co-authored the *Final Report: Direct Potable Reuse Resource Document* prepared in 2015 for the Texas Water Development Board. McDonald received a BS in Civil Engineering from Bucknell University and both an MS and PhD in Water Resources Engineering from Stanford University.

Adam Olivieri, DrPH, PE. Adam Olivieri has 35 years of experience in the technical and regulatory aspects of water recycling, groundwater contamination by hazardous materials, water quality and public health risk assessments, water quality planning, wastewater facility planning, urban runoff management, and onsite waste treatment systems. He has gained this experience through working as a staff engineer with the California Regional Water Quality Control Board (San Francisco Bay Region), staff specialist (and postdoctoral fellow) with the School of Public Health at the University of California, Berkeley, project manager/researcher for the Public Health Institute, and a consulting engineer. He is currently the vice president of EOA, Inc., where he manages a variety of projects, including the Santa Clara County Urban Runoff Program since 1998. Olivieri is also the author or coauthor of numerous technical publications and project reports. He serves as co-chair of an NWRI Expert Panel for the state of California on developing water recycling criteria for indirect potable reuse through surface water augmentation and determining the feasibility of developing criteria for direct potable reuse. Olivieri received a BS in Civil Engineering from the University of Connecticut, an MS in Civil and Sanitary Engineering from the University of Connecticut, and both an MPH and DrPH in Environmental Health Sciences from University of California, Berkeley.

Andrew Salveson, PE. Andy Salveson is vice president and water reuse chief technologist at the national engineering firm of Carollo Engineers, Inc., where he leads advanced technology research and development and oversees Carollo's advanced wastewater treatment designs. He leads the planning, permitting, and design of direct and indirect potable reuse facilities across the southwestern United States. He has led over \$6 million in advanced treatment research, including numerous projects for the California Direct Potable Reuse Initiative. In addition, he serves on an NWRI Independent Advisory Panel for the development of potable reuse regulatory guidance in New Mexico, as well as the WHO team to develop international guidelines for direct and indirect potable reuse. Salveson received a BS in Civil Engineering from San Jose State University and an MS in Environmental Engineering Technology/Environmental Technology from the University of California, Davis.

R. Shane Trussell, PhD, PE, BCEE. Shane Trussell is president of Trussell Technologies, Inc., an engineering firm based in Pasadena, CA. He is a registered civil engineer in the state of California with 17 years of experience who has authored more than 84 publications and presentations. His professional experience has focused on treatment processes and water quality issues associated with emerging drinking water supplies, such as potable reuse, seawater desalination, and impaired groundwater. After beginning his potable reuse career studying virus rejection with membranes in the 1990s, he continues similar work today, leading direct potable reuse research projects and investigating the treatment barriers and online monitors that make potable reuse projects reliable enough for acceptance with regulatory agencies yet economical. Currently, he is supporting a number of water agencies with the development of potable reuse projects for reservoirs and groundwater basins throughout California. In addition, he is a recognized expert on membrane bioreactors and has an intimate understanding of the process limitations for high organic loadings and high mixed-liquor suspended solids. Trussell received a BS in Chemical Engineering from the University of California, Riverside, an MS in Environmental Engineering from the University of California, Los Angeles, and a PhD in Environmental Engineering from the University of California, Berkeley, performing his doctoral research on the effects of mixed-liquor properties on membrane performance in the membrane bioreactor process.

2. Editors

Jeffrey J. Mosher. Jeff Mosher has extensive experience in water supply and water resources, including water reuse with an emphasis on indirect and direct potable reuse. For the past 10 years, he has served as executive director of NWRI, a 501c3 nonprofit focused on improving water quality and protecting public health. In this capacity, he oversees project management, strategic planning, financial management, and conference and meeting planning. Under his leadership, NWRI has supported projects, publications, and events focused on potable reuse, desalination, and other areas of advanced water treatment. He also has led more than 30 NWRI independent advisory panels for water, wastewater, and state agencies addressing water quality, treatment options, and the implementation of complex projects and policies; this effort includes administering an expert panel on evaluating the feasibility of developing water recycling criteria for direct potable reuse for the state of California. Through NWRI, Mosher serves as administrative director for the Southern California Salinity Coalition. His extensive background in association and research foundation management includes previous positions for the WateReuse Association, WateReuse Research Foundation, and Association of Metropolitan Water Agencies. Mosher received a BS in Chemistry from the College of William and Mary and an MS in Environmental Engineering from George Washington University.

Gina Melin Vartanian. Gina Vartanian is an experienced writer and editor, specializing in water resources and technology. Since 1998, she has served as an editor, writer, and project manager for NWRI, a 501c3 nonprofit focused on improving water quality and protecting public health. As communications and outreach manager, she focuses on publications, website and social media development, grant proposals, and program development for conferences, workshops, and others. She has edited hundreds of technical documents for the water industry, including NWRI's *Ultraviolet Disinfection Guidelines for Drinking Water and Water Reuse* and the textbook *Riverbank Filtration: Improving Source-Water Quality*. Vartanian also provides editorial support for NWRI's Independent Advisory Panel program, attending panel meetings and assisting with panel reports. These efforts include panels to review potable reuse projects for agencies like the Orange County Water District (CA), Village of Cloudcroft (NM), and El Paso Water Utilities (TX), as well as an expert panel on evaluating the feasibility of developing water recycling criteria for direct potable reuse for the state of California. Vartanian received a BA in English Literature and a Master of Professional Writing from the University of Southern California.



